

TAKE CONTROL

[www.samyangsys.com](http://www.samyangsys.com)

[www.samyangsys.com](http://www.samyangsys.com)

**SAMYANG**  
SYSTEM GROUP

SAMYANG Valve

SAMYANG-Arca

SEM System

Eco-enerdigm

  
SAMYANG VALVE CO., LTD.

VOL. 11  
SAMYANG VALVE PRODUCT CATALOG

VOL.  
11

# SAMYANG VALVE PRODUCT CATALOG

 **SAMYANG VALVE**  
*Rich Valve Experience*

 **SAMYANG VALVE CO., LTD.**

#48-14 SAMJEONG-DONG, OJEONG-GU, BUCHEON-SI, GYEONGGI-DO, 421-808, KOREA  
TEL\_+82.32.678.3121~3 / FAX\_+82.32.681.1117 [www.samyangvalve.co.kr](http://www.samyangvalve.co.kr)

- The colors of the products may be slightly different from the actual ones, due to the printing process.
- The product appearance, specifications, etc. are subject to change without prior notice for product improvements.

VOL.  
11

[www.samyangsys.com](http://www.samyangsys.com)

# SAMYANG VALVE PRODUCT CATALOG



**SAMYANG VALVE**

*Rich Valve Experience*



**Since 1960**

“Remaining faithful to the tradition of system engineering and valve making, we, **SAMYANG SYSTEM GROUP** invites you to share our 50 years of expertise and experience.”

**SAMYANG**  
SYSTEM GROUP



## ENVIRONMENT · ENERGY · DESIGN

As a company at the vanguard of green technology, which leads the environment, design, and energy, Samyang System Group actively conducts research and offers clean environment-friendly energy, environment-friendly design, and environment-friendly technology, giving new hope to mankind and nature.



# SAMYANG

SYSTEM GROUP



SAMYANG Valve  
[www.samyangvalve.co.kr](http://www.samyangvalve.co.kr)



SAMYANG-Arca  
[www.samyang-arca.co.kr](http://www.samyang-arca.co.kr)



SEM System  
[www.semsys.co.kr](http://www.semsys.co.kr)



Eco-enerdigm  
[www.eed.co.kr](http://www.eed.co.kr)







## Environmentally Friendly, SAMYANG SYSTEM GROUP,

SAMYANG SYSTEM GROUP stands by the side of sustainability and environment-friendliness. It offers environmentally friendly energy saving products to help you make greener life style choices. It dreams of making today a better one and a bright future.



## Contents

		
<b>Message from the CEO</b>	<b>009</b>	
<b>History Highlights</b>	<b>010</b>	
<b>About Samyang System Group</b>	<b>012</b>	 ...
		SAMYANG VALVE
		SAMYANG-ARCA
		SEM SYSTEM
		ECO ENERDIGM
<b>Samyang Valve Products</b>	<b>019</b>	 ...



## **SAMYANG SYSTEM GROUP**

Headquarter in Bucheon, Korea

## ■ Message from the CEO

### — We love to share our experience to make your life better

SAMYANG SYSTEM GROUP, as a leading company in the field of valve manufacturing and system engineering, is providing its 50 years experience to make a comfortable and clean living environment with the world's top technology.

Since the establishment in 1960, SAMYANG SYSTEM GROUP has put continuous efforts to make the highest quality automatic valve products for the efficient energy management within the construction and industrial equipment field, and by that way, thanks to its sustained technical investment, SAMYANG established its valve production plant in 1971. In this regard, SAMYANG has been recognized as a company enabling the domestic planning and manufacturing for the valves, which depended only on import, and awarded President's Awards for Enterprise several times for rendering great services to the development of the nation's economy. The President's Award for Enterprise is the highest honorary award that the Korean Government can grant.

Through accumulated technologies with continuous Research & Development and experiences, SAMYANG SYSTEM GROUP has been keeping the firm superiority in the field of domestic and overseas construction development and industrial plants, and has been recognized by the customers with the top-quality products and the highest services.

For the 21<sup>st</sup> century, SAMYANG SYSTEM GROUP is born again as a company considering environment and energy to provide the optimum indoor living environment where engineering and environment are harmonized. SAMYANG has researched hand-in-hand with the worldly-renown corporations and universities and produced new generation indoor environmental products to make the environment healthier and cleaner and increase energy efficiency : Hot Water Distributor, Internet-based Home Automation System, Ventilating, Humidification and Radiant Cooling/Heating System.

Thanks to its technical expertise, research re-investment and highly creditable products and after-sales service, SAMYANG has always raised its reputation and will go on being raised by providing the high-quality indoor environmental control system embedded with high technology.

**Yang, Chang Duck**  
CEO

## History Highlights

1960 ~ 1990



1960

- Samyang Water Work Company established (Sillim-dong, Jung-gu, Seoul)

1971

- Renamed to Samyang Comprehensive Valve Co., Ltd. with the establishment of the current plant that has a floor space of approximately 826 m<sup>2</sup> on a site spanning approximately 14,770 m<sup>2</sup>

1972

- Plant registered (Gyeonggi No. 3-58-24)
- Plant expanded (by approximately 866 m<sup>2</sup>)
- Type approved for safety valve (Industrial Advancement Administration No. 1-2002-99)

1975

- Various valve test facilities completely equipped
- Appreciation letter from Minister of Commerce, Industry and Energy received after exhibition of products at a machinery exhibition held by Export Promotion Corporation



1978

- State-of-the-art precision processing machinery introduced from Gragiono of Italy (ARD loan)

1981

- Technology Research Institute of Samyang Comprehensive Valve established
- Chosen as a pilot factory technology-leading company by Industrial Advancement Administration of Ministry of Commerce, Industry and Energy
- Plant No. 4 built

1982

- KS mark received from Korea Industrial Standard
- Approval for manufacturing of firefighting equipment and fixtures received (Gyeonggi Province No. 3-27)
- Approval for manufacturing of high pressure gas equipment received (Gyeonggi Province No. 82-55-24)
- Minister of Commerce, Industry and Energy Award received at Nationwide Plant Saemaeul Quality Control Contest
- Trade business registered (Gyeonggi Province)
- High pressure boiler for testing installed for the first time in Korea (50 kgf/cm<sup>2</sup>; 2.6 tons)



1983

- Approval received for types of pressure inspection device and running water inspection device for firefighting equipment (No. 83-4-1014)
- Approval received to deliver expansion joint product to Far Eastern U.S. Construction Committee

1989

- SAMYANG-ARCA Co., Ltd. established based on joint investment with ARCA REGLER GMBH of Germany

1994

- Chosen as power generation facility manufacturer by KEPCO (Safety and relief valves)

1997

- Presidential Corporate Award received

1998

- ISO-9001 certification acquired (BVQ)



## 2000 ~ 2010

### 2000

- Fourth Industrial Safety Machinery Exhibition
- Encouragement Award received (Korea Occupational Safety & Health Agency)
- KS mark received from Korea Industrial Standard (KS B 2373, 2374)



### 2002

- Outstanding quality certificate (EM mark) acquired
- Pressure reducing valve for steam (YPR-100) and diaphragm-type automatic flow control valve (YFC-2N) developed
- Chosen as localized high pressure safety valve developer by Ministry of Commerce, Industry and Energy
- Products exhibited at HVAC, a leading international exhibition on heating, ventilation, air-conditioning, refrigeration, air filtration and purification (Singapore)
- Products exhibited at AHR Expo (Atlanta, U.S.)

### 2003

- SEM System Co., LTD. established
- Products exhibited at AHR Expo (Chicago, U.S.)
- Outstanding quality certificate (EM mark) acquired (minute heating flow control system : SEM Station)
- Products exhibited at Cooling/Heating Exhibition in Shanghai, China
- U.S. patent acquired for constant flow valve (YFC-2N)



### 2005

- Products exhibited at AHR Expo (Anaheim, U.S.)
- BEST INC. is established as a Joint ventur with seoul national university
- Engineering Testing Laboratory, Seoul National University Institution of Engineering established.

### 2006

- Heating temperature control system for each room developed
- Q mark acquired

### 2007

- Turbine bypass valve delivered by SAMYANG-ARCA to Hwaseong Combined Heat & Power Plant
- Radiant Cooling/Heating Simulation Exhibition Hall built
- High-efficiency energy equipment certificate acquired (automatic temperature controller for heating)

### 2009

- Established a Joint Venture with RDZ of Italy
- Developed active auto flow regulating system (SEM II Smart System)

### 2010

- Samyang System Group 50th anniversary
- Acquired NET(New Exellent Technology) certification (SEM II Smart System)

## Prizes & Certifications





# SAMYANG VALVE

## Rich Valve Experience

#48-14 Samjeong-dong, Ojeong-gu, Bucheon-si,  
Gyeonggi-do, 421-808, Korea  
Tel : 82-32-678-3121-3 / Fax : 82-32-681-1117



Since its founding in 1960, Samyang Valve Co., Ltd. has been producing automatic valves for fluid control to ensure efficient energy management in the construction and industrial facility fields. The company is recognized for its high-quality products by many customers at home and abroad.

Samyang Valve has fully established itself as a leader in the domestic valve industry, thanks to continuous efforts made to enhance customer satisfaction based on research and development of products that meet the specific needs of customers; and to manufacture products that are appropriate for conditions on the field where construction and industrial facilities are used.

Based on advanced technology and extensive experience, Samyang Valve will continue to manufacture high-quality, high-performance products. The company will take a step further by offering more value to customers with a customer-oriented mindset.



- Pressure Reducing Valve
- Constant Flow Temperature Control Valve
- Primary Pressure Control Valve
- Safety Valve
- Steam Trap
- Control Valve for District Cooling and Heating
- Level Control Valve
- Bellows Type Expansion Pipe Joint
- Flexible Tube
- Water Separator
- Control Check Valve
- Strainer
- Hammerless Check Valve
- Suction Diffuser
- Air Vent Valve
- Ball, Slip, Multi Joint



# SAMYANG-ARCA

## Most Advanced Valve Technology

#48-11 Samjeong-dong, Ojeong-gu, Bucheon-si,  
Gyeonggi-do, 421-808, Korea  
Tel : 82-32-678-6390-1 / Fax : 82-32-678-3124



Samyang-Arca Co., Ltd. was established in 1987 through a technology alliance and a joint investment with Germany' ARCA-Regler GmbH, a professional control valve company with a tradition of 100 years. Since then, for more than 20 years Samyang-Arca has been manufacturing control valves, which are essential for key industries of a nation, and supplying them in Korea and abroad. Samyang-Arca has been manufacturing and supplying control valves such as valves used in an extremely low temperature of -190 ANSI 4500# class high pressure and / or high temperature regulating valves, and turbine bypass valves that function even at 1,000 MW-level power plants. Samyang-Arca' control valves work at a wide array of plants in Korea and abroad, including thermal power plants, nuclear power plants, desalination plants, heat recovery steam generators (HRSG), combined heat and power plants, petrochemical plants, as well as iron and steel manufacturing plants. Samyang-Arca always makes efforts to satisfy customer needs and seeks to offer highly reliable products to meet customer expectations.



### Brewing and shipbuilding industry

The SAMYANG-ARCA control valves for sour gas and solids-containing media feature little pressure loss and can be effectively applied in low temperatures, just like the high-capacity microflow valve and butterfly valve.

SAMYANG-ARCA has been developing valves for impact and vibration prevention that can also be used in the shipbuilding industry.

The company's "bio-valve" series satisfy the sanitation regulations in the food and drink manufacturing industry. The series can be applied in various areas, ranging from food and drink manufacturing to bottle factories, thanks to its outstanding performance in terms of functions as well as installation.

### Petrochemicals industry

Energy use is being brought down through accurate selection of standard sizes that are needed for different processes, such as those for paper, textile, sugar, rubber, and plastic.

### Metal and steel industry

The company's products can be installed in various ways, based on their measurement range and unique strengths that allow them to meet specific requirements in the metal and steel industry concerning high pressure and high temperature.





# SEM SYSTEM

## Smart Heating

#48-115 Samjeong-dong, Ojeong-gu, Bucheon-si,  
Gyeonggi-do, 421-808, Korea  
Tel : 82-32-710-8230~3 / Fax : 82-32-673-6560



Sem System Co., Ltd. was established in 2003 through a technology alliance with Italy's Caleffi, a worldwide manufacturer of hydronic solutions including pressure reducing valves, tempering valve, RPZ, double check valves, and other products for heating and HVAC applications. with a tradition of 40 years. Since then, Sem System has been manufacturing and supplying the European-style distribution system for heating. It was the first European-style distribution system of an underfloor heating system introduced in Korea, thereby saving energy and further upgrading the home floor heating culture. Beyond the simple hot water distribution function of existing distribution systems, the Sem System's distribution system is a modular system that is designed to save energy through flow control by room and to maintain a pleasant indoor temperature. Moreover, its slim and compact structure ensures easy installation and maintenance. Therefore, the Sem System's distribution system is an effective product that improves work efficiency and allows convenient use of residents. Through continuous adoption of globally advanced heating technology and R &D, Sem System keeps developing and offering new products that effectively cut down energy use.



- DISCAL, a water separator
- Pressure reducing valve by household
- Adjustable automatic supply equipment
- Adjustable pressure reducing valve
- Temperature regulating equipment
- Pressure reducing valve by household
- Temperature-adjustable mixing valve

**SEM Total Solution System**



# ECO·ENERDIGM

## RDZ INVISIBLE Heating & Cooling

#48-117 Samjeong-dong, Ojeong-gu, Bucheon-si,  
Gyeonggi-do, 421-808, Korea  
Tel : 82-32-672-0874 / Fax : 82-32-672-0876



Eco-enerdigm was built on the technology of Samyang System Group that was founded in 1960. Since 2003, Eco-enerdigm has been testing and researching radiant cooling and heating system and has adopted the European radiant cooling system that is eco-friendly. In year 2007, an Italian company, RDZ (the specialty company of radiant system), has offered their 40 years of knowledge and experience in radiant cooling system. Now Eco-enerdigm can offer both the best technology and local knowledge from the two companies above and provide every need from system designs, installations to after services.



## Total Solution System





## **SAMYANG VALVE**

### **Developing Energy Saving Products and Solutions**

Since 1960, SAMYANG VALVE is a leader in the valve industry and marked an impressive record of firsts. It has been developing innovative energy saving systems, and enhances every product with the vision of the best company offering innovative energy saving solutions. SAMYANG VALVE offers the most appropriate energy-saving systems for your energy efficient home and building projects.





# SAMYANG VALVE

SINCE 1960

## RICH VALVE EXPERIENCE

### FACTORIES



- Industrial machinery • Automobiles • Food
- Shipbuilding • Semiconductors • Pharmaceuticals
- Textile • Animal feed

### ENVIRONMENT



- Water and wastewater treatment facilities
- Waste disposal sites • Golf courses
- Sprinkling water at parks • Agricultural water

### PLANTS



- Power plants • Nuclear energy
- Space power generation • Pharmaceuticals
- General chemistry • Petrochemistry
- Oil economy • Paper manufacturing

### GENERAL



- Air-conditioning equipment • Sanitation facility
- Cooling/heating • Steam/hot water/cold water lines
- Fire-fighting equipment • Water supplying/heating



## C O N T E N T S

---

Application Diagram .....	020
Products Index .....	022
Products .....	
1. PRESSURE REDUCING VALVE .....	023
2. SAFETY VALVE .....	051
3. STEAM TRAP .....	069
4. CONTROL VALVE FOR DISTRICT COOLING AND HEATING .....	081
5. LEVEL CONTROL VALVE .....	103
6. STRAINER / WATER SEPARATOR .....	111
7. BELLOWS TYPE EXPANSION PIPE JOINT / FLEXIBLE TUBE .....	121
8. BALL / SLIP / MULTI JOINT .....	135
9. HAMMERLESS CHECK VALVE / FOOT VALVE .....	153
10. AIR VENT VALVE .....	159
11. CONTROL CHECK VALVE / SUCTION DIFFUSER .....	163
12. REFERENCE DATA .....	167



# Application Diagrams

## Boiler/heat exchanger facility

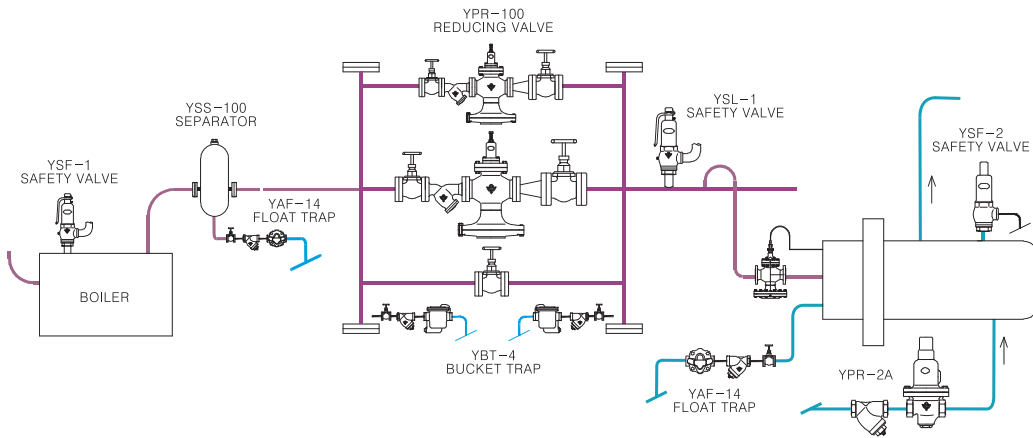

## Water supplying/heating facility

### Apartment Building

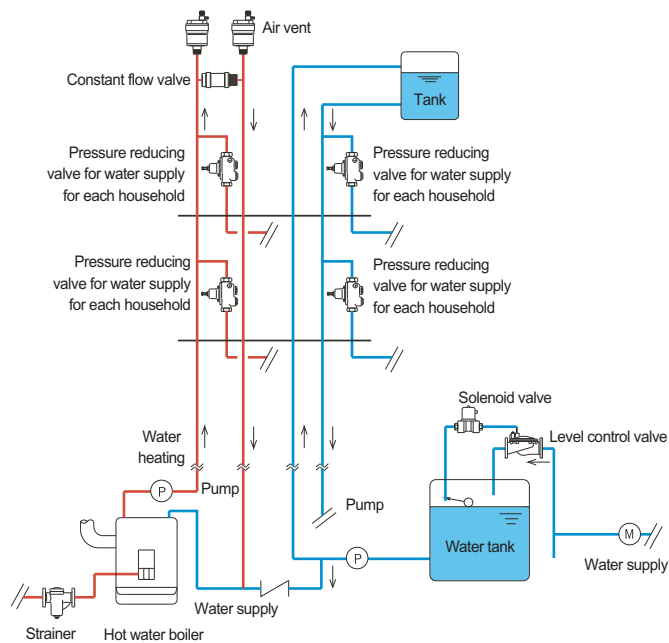

### Each Household

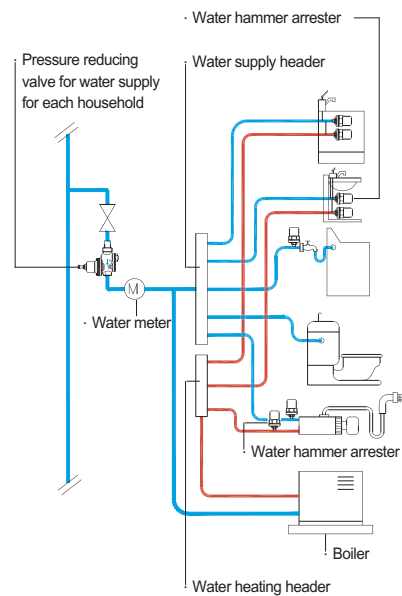

## District cooling/heating facility

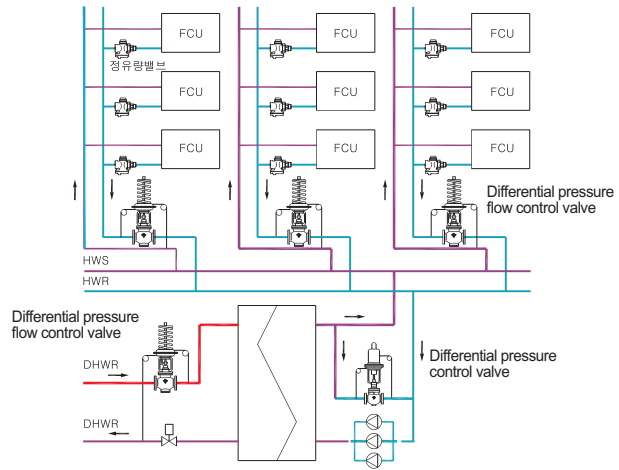

## Level control valve facility

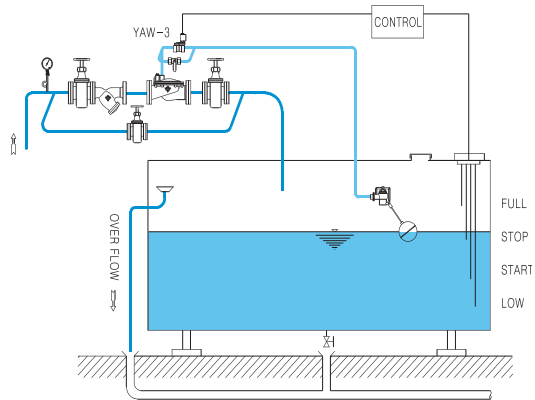

## Constant flow temperature control facility

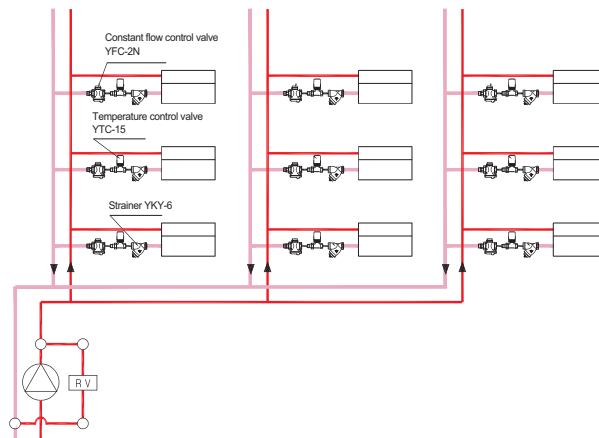



## PRODUCTS INDEX

Model No.	Page	Model No.	Page	Model No.	Page	Model No.	Page
YPR-100	24	YSL-2	56	YDP-1F	93	YBJ-4S	125
YPR-100A	24	YRV-1	57	YDP-20F	93	YBJ-4W	125
YPR-1S	26	YRV-2	57	YAW-3S	104	JSY-9B	126
YPR-50	28	YAF-14S	70	YAW-3F	104	JSY-9C	126
YPR-8S	29	YAF-14F	70	YAWEL-1	107	BG/BI series	136
YPR-8U	29	YBT-4	71	YKY-1	112	SIS/SID series	137
YPR-8G	30	YSP-1, 2	72	YKY-2	112	SGS/SGD series	138
YPR-8A	30	YSP-5	74	YKY-11	113	MJ-1/MJ-2 series	139
YPR-8N	31	YSP-6	74	YKY-12	113	MJ-3 series	140
YPR-8H	31	YRS-3	75	YKY-3	114	BSI series	141
YPR-8E	32	YFC-2N	82	YKY-5B	115	UG-1 series	142
YPR-2A	33	YFC-1S	84	YKY-6	115	YHL-100	154
YAWR-1	35	YFC-1F	84	YBS-6	115	YHL-200	154
YPR-41	37	YFC-2F	86	YUS-1	116	YFV-1	157
YPR-2W	38	YFC-20F	86	① - Strainer	117	YAC-3	160
YAWM-1	40	YBC-2F	87	YSS-100	118	YAC-3A	161
YSF-1	52	YBC-20F	87	YSS-511S	119	YAC-3M	161
YSF-2	52	YTF-20	89	YSS-511F	119	YAC-4	162
YSF-3	53	YFC-20	89	YBJ-1S	122	YCC-1, 1R	164
YSF-4	53	YTC-20	89	YBJ-1W	122	YCC-2, 2R	164
YSF-5	54	YDF-2F	90	YBJ-2S	123	YCC-3, 3R	164
YSF-6	54	YDF-20F	90	YBJ-2W	123	YSD-1, 1R	165
YSF-3(open)	55	DR-08(Control)	92	YBJ-3S	124	YSD-2, 2R	165
YSL-1	56	DR-08(Fixing)	92	YBJ-3W	124	YSD-3, 3R	165

### Samyang manufactures all types of valves needed for the flow of fluid.

This comprehensive catalogue classifies the standard products of Samyang Valve into 11 product types. Products that are currently being developed have not been included in this catalogue. Please consult with Samyang Valve's sales representatives for inquiries on technologies or specifications not included in this catalogue.

Information in the catalogue, including structures, dimensions, and materials of products, may change without prior notice to meet the latest needs of clients and for product improvements.

# Pressure Reducing Valve

# 1

## Pressure Reducing Valve

Effectively used for construction facilities and other industries as a whole, pressure reducing valves stabilize the piping system by reducing high pressure to a set pressure. They are categorized, as per their structure, into pilot, pilot diaphragm, and direct operating types.

### Steam pressure reducing valve

Type	Size	Applicable fluid	Applicable pressure (kgf/cm <sup>2</sup> )		Structure	Materials		End connection	Page
			Primary	Secondary		Body	Disc, seat		
YPR-100	15(1/2")~150(6")	Steam	Maximum 17	0.21~2.1	Pilot	GCD450	STS	KS 10 RF FLANGE	24
YPR-100A			Maximum 30	1.4~7		SCPH2		KS 20K, 30K RF FLANGE	
YPR-1S	15(1/2")~200(8")		Maximum 10	0.35~8		Direct operating	GC200	BC6	KS 10 RF FLANGE
YPR-50	15(1/2")~25(1")		Maximum 14	0.2~10	STS			KS PT SCREW	28

### Steam pressure reducing valve

Type	Size	Applicable fluid	Applicable pressure (kgf/cm <sup>2</sup> )		Structure	Materials		End connection	Page
			Primary	Secondary		Body	Disc, seat		
YPR-8S	15(1/2")~20(3/4")	Cold/hot water	Maximum 10	0.5~1.5	Direct operating	15A:BsC3	VITON/STS	KS PT SCREW	29
YPR-8U						20A:BC6		Inlet : KS PT UNION (8A : KS PT SCREW) Outlet : KS PT SCREW	
YPR-8G	15(1/2")					1.5~3	BsC3		30
YPR-8A						3~5	VITON/PUS		
YPR-8N									1.2~5
YPR-8H						0.5~3.5	KS PT SCREW		
YPR-8E	3~7				KS 10K FF FLANGE				
YPR-2A						15(1/2")~25(1")	0.5~3.5	Pilot	GC200
	32(1 1/4")~150(6")				3~7	KS 10K RF FLANGE			
YAWR-1	200(8")~250(10")						0.5~3.5	Direct operating	SCPH2, STS316
	300(12")~400(16")	3~7	KS 10K RF FLANGE						
YPR-41	15(1/2")~150(6")			Water, vapor	Maximum 20	0.5~12	Direct operating	SCPH2, STS316	NBR/STS

### Primary pressure regulating valve

Type	Size	Applicable fluid	Applicable pressure(kgf/cm <sup>2</sup> )		Structure	Materials		End connection	Page
			Primary	Secondary		Body	Disc, seat		
YPR-2W	15(1/2")~25(1")	Water	Maximum 10	0.5~7	Direct operating	GC200	NBR/BC6	KS PT SCREW	38
	32(1 1/4")~150(6")				Pilot			KS 10K FF FLANGE	
YAWM-1	200(8")~400(16")					KS 10K RF FLANGE	40		

# Type YPR-100, 100A Pressure Reducing Valve For Steam

This pressure reducing pilot diaphragm valve for steam is a self-operated valve that has a high Cv value, and maintains an outstanding level of controllability in primary pressure changes as well as steam equipments' load fluctuations.



## ■ Dimensional drawing

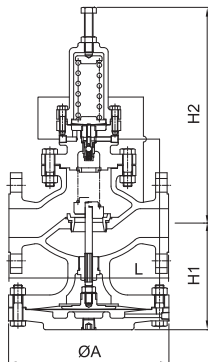

Type 15-40A

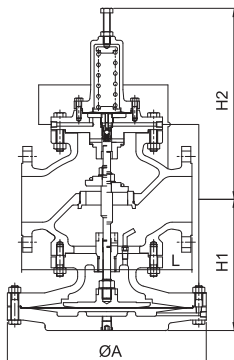

Type 50-150A

## ■ Features

- 20:1 Maximum Pressure Turndown Ratio provides one-stage reduction without the customary costly two stage reduction.
- High Cv value and superb flow-controlling capacity allows even products that are one or two size smaller than the usual nominal diameter.
- Low pressure (0.21 kgf/cm<sup>2</sup>) management is possible.
- Three different springs are employed based on the secondary pressure regulating range, thereby color-differentiating the pressure range based on the pipeline conditions.
- Simple structure, and major moving parts are made of durable stainless steel : removal of an adapter between the main valve and pilot valve enables easy repair and inspection.

## ■ Specifications

Type		YPR-100	YPR-100A
Applicable fluid		Steam	
Primary pressure		Maximum 17 kgf/cm <sup>2</sup>	Maximum 30 kgf/cm <sup>2</sup>
High pressure regulating range		0.21~2.1kgf/cm <sup>2</sup> (for low pressure), 1.4~7.0kgf/cm <sup>2</sup> (for medium pressure), 5.~14.0kgf/cm <sup>2</sup> (for high pressure)	
Maximum pressure reduction ratio		20:1	
Minimum differential pressure in the inlet and outlet side of the valve		0.5kgf/cm <sup>2</sup>	
Leakage allowance		0.01% less of rated flow	
Fluid temperature		220° C below	250° C below
End connection		KS 10K, 20K kgf/cm <sup>2</sup> RF FLANGE	KS 20K, 30K kgf/cm <sup>2</sup> RF FLANGE
Material	Body	GCD450	SCPH2
	Disc, seat	STS	
	Diaphragm	Copper	
Hydraulic test pressure		30 kgf/cm <sup>2</sup>	45 kgf/cm <sup>2</sup>

- ▶ Strainer (over 80 Mesh ) installation is required to ahead inlet when valve installing.
- ▶ Install a water separator at the inlet of the pressure reducing valve to ensure the removal of condensate.

## ■ Pressure regulating spring range

Yellow	0.21~2.1kgf/cm <sup>2</sup>
Red	1.4~7.0kgf/cm <sup>2</sup>
Blue	5.6~14.0kgf/cm <sup>2</sup>

## ■ Dimensions

Size	L	ØA	H1	H2	Cv	Weight (kg)
15(1/2")	130(130)	196	140(127)	273(130)	5	17.5
20(3/4")	150(150)	196	135(130)	281(130)	7.2	18
25(1")	184(197)	223	150(135)	283(130)	10.9	23.5
32(1 1/4")	180(180)	223	163(143)	293(130)	14.3	24.5
40(1 1/2")	222(235)	223	173(148)	297(130)	18.8	26
50(2")	254(267)	272	195(194)	292(130)	32	41.5
65(2 1/2")	276(292)	348	255(227)	327(130)	60	69.5
80(3")	298(318)	348	260(230)	332(130)	78	75
100(4")	352(368)	402	285(252)	343(130)	120	97.5
125(5")	400	460	330(368)	415(368)	160	180
150(6")	451(473)	530	384(368)	445(368)	245	230

- ▶ Dimensions in parenthesis are for YPR-100A.

## ■ Application Diagram (Example)

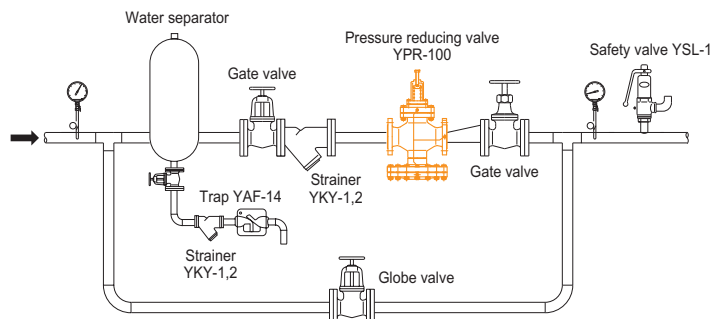

# Type YPR-100, 100A Pressure Reducing Valve

## ■ Chart on selecting a size

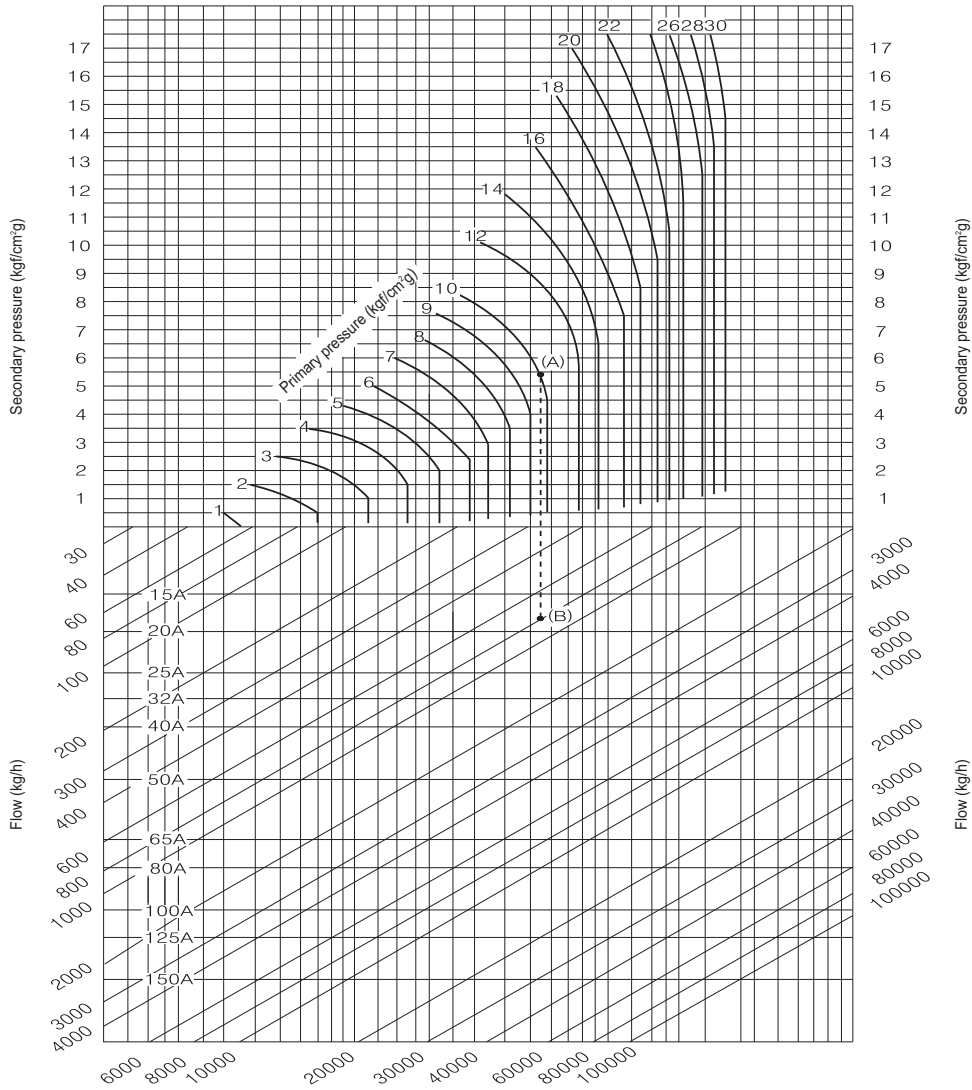

## How to select the size of a valve by the chart

Example) If the primary pressure is 10 kgf/cm<sup>2</sup>, secondary pressure is 5.5 kgf/cm<sup>2</sup>, and flow is 800 kg/h,

- 1) Determine "A," the point of intersection between the primary pressure (10 kgf/cm<sup>2</sup>) and secondary pressure (5.5 kgf/cm<sup>2</sup>).
- 2) Go down vertically from "A" to make intersection "B" with the flow (800 kg/h). Now that "B" is in between a size of 15A and 20A, a size of 20A should be selected.

## ■ Flow characteristics chart

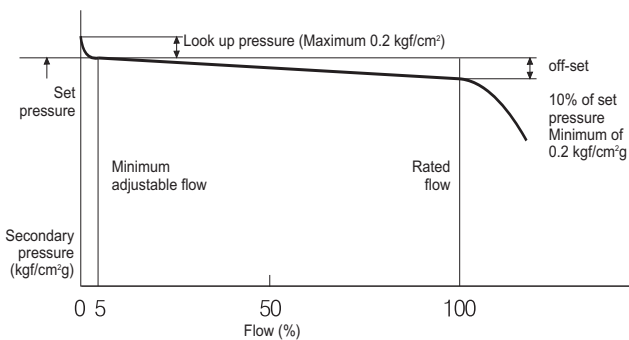

## ■ Pressure characteristics chart

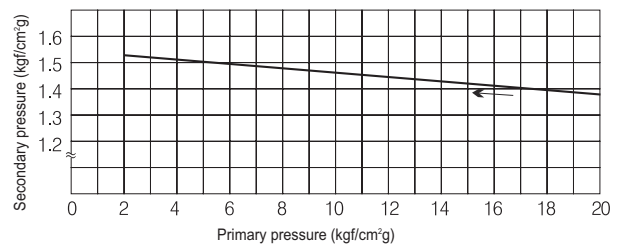

► Assuming that the secondary pressure was set to 1.4 kgf/cm<sup>2</sup>, while the primary pressure was 17.5 kgf/cm<sup>2</sup>, this chart shows changes in the secondary pressure when the primary pressure is adjusted to between 2 and 14 kgf/cm<sup>2</sup>.

# Type YPR-1S Pressure Reducing Valve For Steam

This pressure reducing valve, which is used for construction facilities and industrial steam lines, demonstrates stable control and subtle operations. It features an outstanding performance even with severe changes in the steam flow and primary pressure.



## ■ Features

- Pilot-type pressure reducing valve for steam features a precise adjustment function.
- With only a single adjustment, a constant pressure level is maintained, thereby ensuring safety.
- Convenient piping construction, thanks to its simple structure and solidity.
- Superb performance even in places where primary steam pressure changes are severe.
- Pressure at a constant level, regardless of changes in the secondary flow.

## ■ Specifications

Applicable fluid	Steam	
Primary pressure	Maximum 10 kgf/cm <sup>2</sup>	
Secondary pressure regulating range	0.35~5 kgf/cm <sup>2</sup> (for standard pressure) 4~8 kgf/cm <sup>2</sup> (for medium pressure)	
Maximum pressure reduction ratio	10:1	
Minimum differential pressure in the inlet and outlet side of the valve	0.7kgf/cm <sup>2</sup>	
Leakage allowance	0.05% less of rated flow	
Fluid temperature	220° C below	
End connection	KS 10K RF FLANGE	
Materials	Body	GC200
	Disc, seat	BC6
Hydraulic test pressure	15 kgf/cm <sup>2</sup>	

- ▶ Strainer (over 80 Mesh ) installation is required to ahead inlet when valve installing.
- ▶ Install a water separator at the inlet of the pressure reducing valve to ensure the removal of condensate.

## ■ Dimensions

Size	L	H1	H2	d	Cv	Weight (kg)
15(1/2")	152	63	230	1/4"	1	8.0
20(3/4")	152	63	230	1/4"	2.5	8.0
25(1")	170	71	255	1/4"	4	12.5
32(1 1/4")	200	81	265	1/4"	6.5	16
40(1 1/2")	200	81	265	1/4"	9	16.5
50(2")	215	86	270	1/4"	16	21
65(2 1/2")	245	110	285	3/8"	25	29
80(3")	285	130	295	3/8"	36	39.5
100(4")	320	148	308	3/8"	64	68
125(5")	380	173	368	3/8"	100	83.3
150(6")	420	189	378	3/8"	144	101
200(8")	500	229	451	3/8"	256	183

## ■ Dimensional drawing

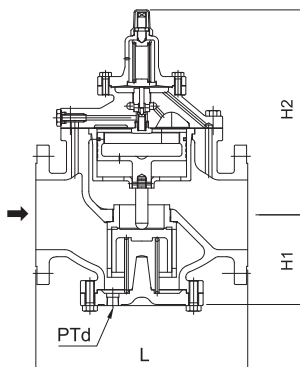

## ■ Application Diagram (Example)

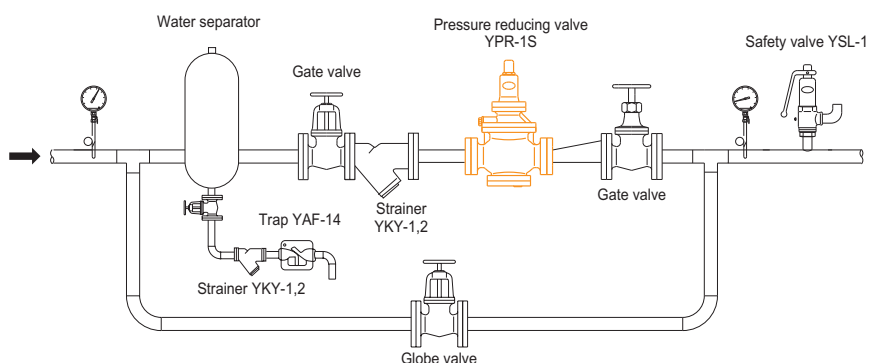

# Type YPR-1S Pressure Reducing Valve

## ■ Chart on selecting a size

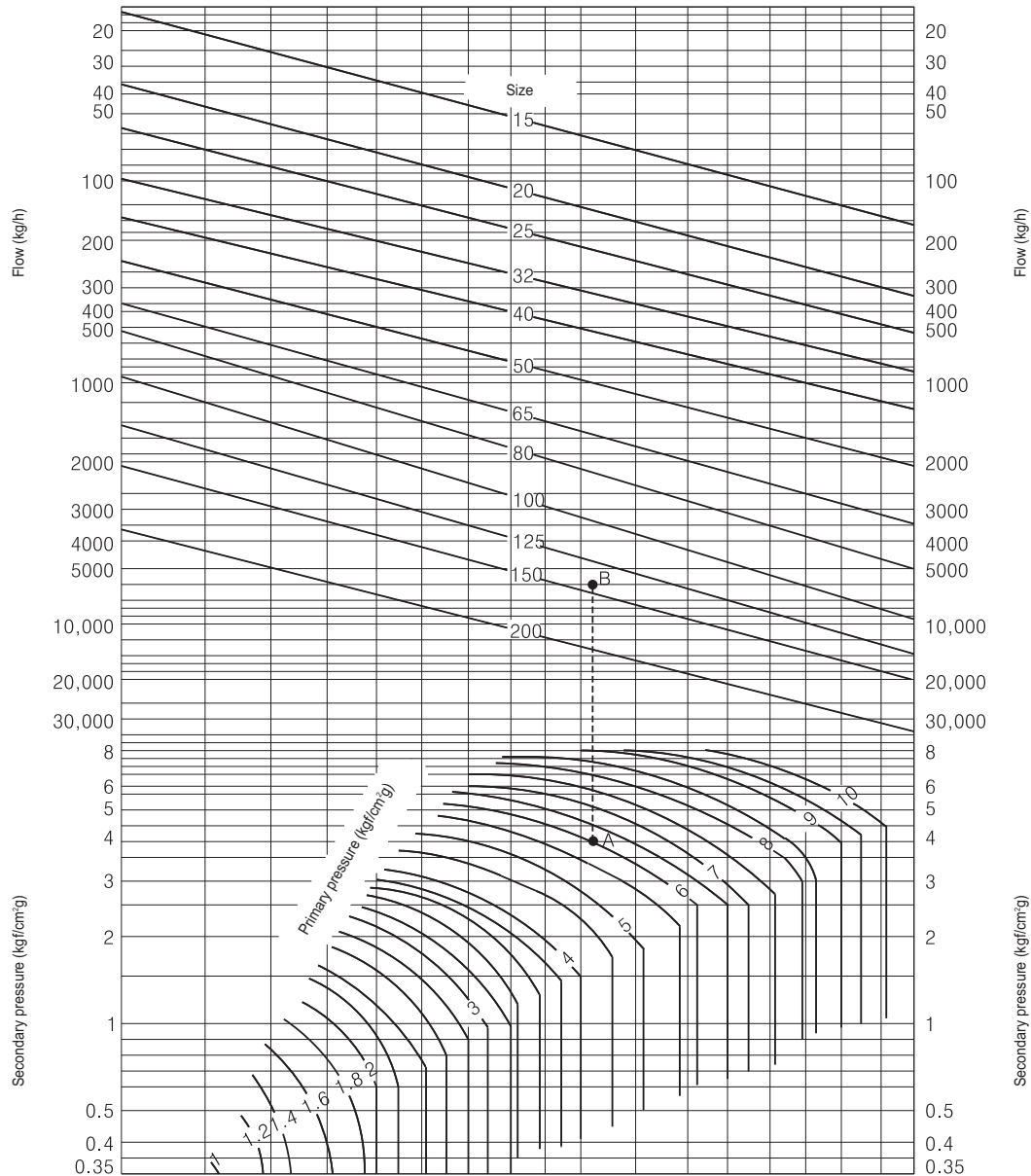

### How to select the size of a valve by the chart

Example) If the primary pressure is 6 kgf/cm<sup>2</sup>g, secondary pressure is 4 kgf/cm<sup>2</sup>g, and flow is 6,000 kg/h,

- 1) Determine "A," the point of intersection between the primary pressure (6 kgf/cm<sup>2</sup>g) and secondary pressure (4 kgf/cm<sup>2</sup>g). Go down vertically from "A" to make intersection "B" with the flow (6,000 kg/h).
- 2) This "B" is what determines the size of the valve. It is in between a size of 125 and 150, and therefore a size of 150 should be selected.

# Type YPR-50 Pressure Reducing Valve For Steam

As a direct operating pressure reducing valve for steam that can be used for pipelines and a wide array of steam facilities, this product can be employed for various purposes in an environment with small flow.



## ■ Features

- Direct operating pressure reducing valve for small flow for outstanding pressure control performance and wide pressure regulating range.
- Stainless steel components for corrosion resistance, long service life and durability.

## ■ Specifications

Applicable fluid		Steam
Primary pressure		Maximum 14 kgf/cm <sup>2</sup> g
Secondary pressure regulating range		0.2~1 kgf/cm <sup>2</sup> g (for low pressure), 1~2 kgf/cm <sup>2</sup> g (for medium pressure), 2~10 kgf/cm <sup>2</sup> g (for standard pressure)
Maximum pressure reduction ratio		10:1
Minimum differential pressure in the inlet and outlet side of the valve		0.5kgf/cm <sup>2</sup>
Fluid temperature		220°C below
Leakage allowance		0.05% less of rated flow
End connection		KS PT SCREW
Materials	Body	GC200
	Disc, seat	STS
Hydraulic test pressure		21 kgf/cm <sup>2</sup> g

- ▶ Strainer (over 80 Mesh ) installation is required to ahead inlet when valve installing.
- ▶ Install a water separator at the inlet of the pressure reducing valve to ensure the removal of condensate.

## ■ Dimensions

Size	L	H1	H2	Weight (kg)
15(1/2")	110	54	180	5.5
20(3/4")	110	54	180	5.5
25(1")	144	66	256	8.6

## ■ Capacity

Primary pressure (kgf/cm <sup>2</sup> g)	Secondary pressure (kgf/cm <sup>2</sup> g)	Size			Primary pressure (kgf/cm <sup>2</sup> g)	Secondary pressure (kgf/cm <sup>2</sup> g)	Size			
		15(1/2")	20(3/4")	25(1")			15(1/2")	20(3/4")	25(1")	
1.0	0.5	3.4	3.9	6.5	7.0	5.6	14.3	17	27.9	
	0.9	3.7	3.4	7.4		4.6	15.8	18.4	30.7	
1.4	0.5	3	3.9	4.4		2.8	13.9	16.2	26.4	
	1.6	4.4	5	7.9		0.7	4.8	5.6	9.3	
2.1	1	3.7	4.2	7.1		8.4	6.8	16.2	19.4	31.8
	0.2	2.3	2.8	4.2			4.9	19.4	21.9	36.4
2.8	2.3	7	8.5	13.2	3.2		16.9	18.8	31.6	
	1.4	5.6	6.8	11.2	0.8	7.7	8.5	13.9		
	0.3	2.8	3.9	5.4	10.6	8.4	20.2	23.4	38.7	
3.5	2.8	9.1	10.1	17		6	25.6	29.6	50	
	1.4	7	8.1	13.2		3.9	21	24.8	41.8	
	0.4	3.4	4.4	6.2		1	9.3	11.6	17.9	
4.2	3.4	9.6	10.8	18.6	12.7	9.8	28.7	34.1	55.8	
	2.8	10.6	11.6	20.3		8.1	30.2	35.6	60.5	
	1.3	6.3	7.3	12		4.9	27.1	30.2	52	
	0.4	3.9	5.1	7		1.3	11.6	13.2	21.7	
5.6	4.5	12.4	14.4	24	14.0	9.8	32.4	36.4	61.2	
	3.8	13.1	15.8	24.8		8.1	33.3	38	63.6	
	1.6	8.5	9.6	15.5		5.6	30.2	34.9	58.2	
	0.6	4.2	5.4	7.6		1.4	14.7	17	27.1	

## ■ Dimensional drawing

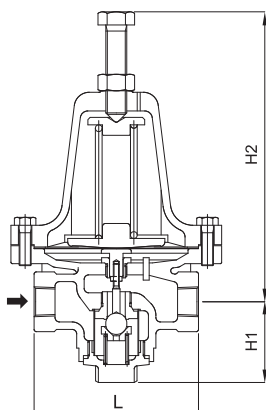

## ■ Application Diagram (Example)

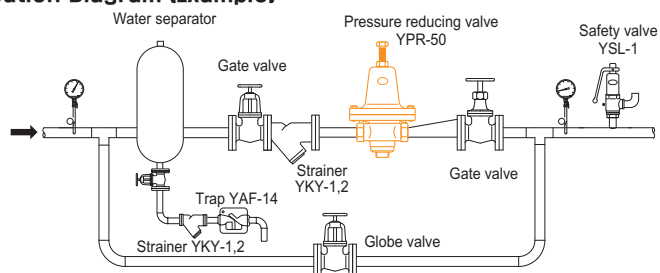

# Type YPR-8S, 8U Pressure Reducing Valve for Heating and Supplying Water for Each Household

Pressure reducing valves that are used to supply water to each household are designed to resolve problems that arise from a pressure imbalance in water supplied to households. They promote user convenience by allowing easy changes of the pipeline direction in accordance with field conditions.



Type YPR-8S



Type YPR-8U



Option (Check valve)

## ■ Features

- Irregular pressures control among households in apartment buildings : it prevents waste of water resources.
- A pressure gauge can be attached for precise identification of adjusted pressure.
- Two ways to install : horizontally or vertically.
- No damage caused by high pressure : a diaphragm with special fiber cloth ensures it.
- A constant pressure level with only a single adjustment.
- YPR-8U : as a union type, the pipeline can be changed easily according to field conditions.
- Options : (1) precise identification of adjusted pressure; (2) installation space reduction.

## ■ Specifications

Type	YPR-8S	YPR-8U
Size	15(1/2") ~ 20(3/4")	
Applicable fluid	Cold/hot water	
Primary pressure	10kgf/cm <sup>2</sup> g	
High pressure regulating range	0.5~1.5kgf/cm <sup>2</sup> g (for low pressure), 1.5~3kgf/cm <sup>2</sup> g(for medium pressure), 3~5kgf/cm <sup>2</sup> g(for high pressure)	
Applicable fluid temperature	120°C below	
Maximum pressure reduction ratio	10:1	
Minimum differential pressure in the inlet and outlet side of the valve	0.5kgf/cm <sup>2</sup>	
End connection	Inlet	KS PT SCREW
	Outlet	KS PT SCREW
Materials	Body : 15A(BsC3) 20A(Bc6) / Diaphragm: EPDM / Disc, seat: VITON or STS	
Hydraulic test pressure	15 kgf/cm <sup>2</sup> g	
Optional	Pressure gauge	Pressure gauge, Check valve

- ▶ Multi-step pressure reduction is needed when the cavitation index is 0.5 or lower.
- ▶ Strainer (over 40 Mesh ) installation is required to ahead inlet when valve installing.

## ■ Dimensions

(mm)

Type	Size	L	H1	H2	Weight (kg)
YPR-8S	15(1/2")	60	24.5	88.5	0.54
	20(3/4")	60	27	96	0.88
YPR-8U	15(1/2")	99	24.5	88.5	0.60
	15(1/2")	110	27	96	0.95

## ■ Flow curve

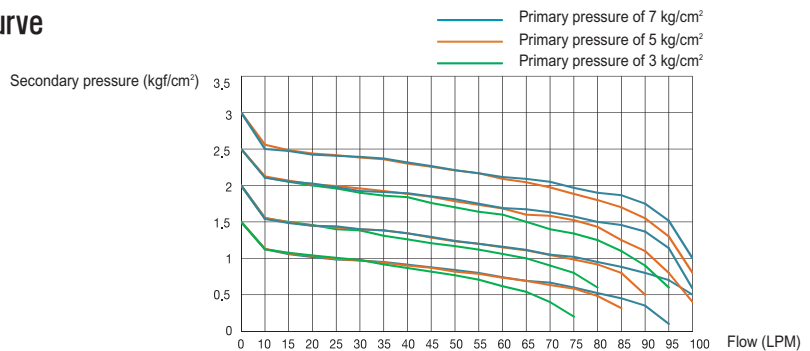

## ■ Dimensional drawing

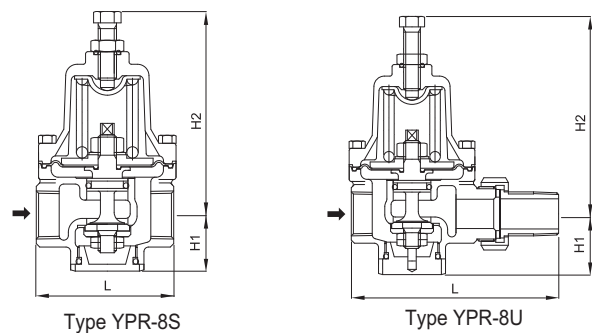

# Type YPR-8G, 8A Pressure Reducing Valve for Heating and Supplying Water for Each Household

Pressure reducing valves that are used to supply water to each household are designed to resolve problems that arise from a pressure imbalance in water supplied to households. They promote user convenience by allowing easy changing of the pipeline direction in accordance with field conditions.



Type YPR-8G



Type YPR-8A1, 2



Optional (Check valve)

## ■ Features

- Irregular pressures control among households in apartment buildings : it prevents waste of water resources.
- A pressure gauge can be attached for precise identification of adjusted pressure.
- Two ways to install : horizontally or vertically.
- No damage caused by high pressure : a diaphragm with special fiber cloth ensures it.
- A constant pressure level with only a single adjustment.
- As a union type, the pipeline can be changed easily according to field conditions.
- YPR-8G, YPR-8C2, YPR-8A2, YPRC-8A2 : the built-in strainer blocks inflow of foreign substances and reduces installation space.
- YPR-8C1,2, YPRC-8A1,2 : it includes the check function so as to prevent the calorie meter from rotating idly by blocking the fluid from flowing backwards.
- The ample opening area of the angle valve minimizes resistance loss, thereby enabling use of larger flow.

## ■ Specifications

Type		YPR-8G	YPR-8A
Size		15(1/2")	
Applicable fluid		Cold/hot water	
Primary pressure		10kgf/cm <sup>2</sup>	
High pressure regulation		0.5~1.5kgf/cm <sup>2</sup> g (for low pressure), 1.5~3kgf/cm <sup>2</sup> g(for medium pressure), 3~5kgf/cm <sup>2</sup> g(for high pressure)	
Applicable fluid temperature		120° C below	
Maximum pressure reduction ratio		10:1	
Minimum differential pressure in the inlet and outlet side of the valve		0.5kgf/cm <sup>2</sup>	
End connection	Inlet	KS PT UNION	KS PT SCREW (Angle type)
	Outlet	KS PT SCREW	KS PT SCREW
Materials	Body	BsC3	
	Disc, seat	VITON, STS	
Hydraulic test pressure		15 kgf/cm <sup>2</sup> g	
Optional		Pressure gauge, Check valve	

- ▶ Multi-step pressure reduction is needed when the cavitation index is 0.5 or lower.
- ▶ Strainer (over 40 Mesh ) installation is required to ahead inlet when valve installing.

## ■ Dimensions

Type	Size	L	H	Specifications
YPR-8G	15(1/2")	88	130	Including screen
YPR-8A1	15(1/2")	108	130	Angle
YPR-8A2	15(1/2")	114	130	Angle+Screen
YPR-8C1	15(1/2")	99	130	Check
YPR-8C2	15(1/2")	105	130	Check+Screen
YPRC-8A1	15(1/2")	108	130	Check+Angle
YPRC-8A2	15(1/2")	114	130	Check+Angle+Screen

## ■ Dimensional drawing

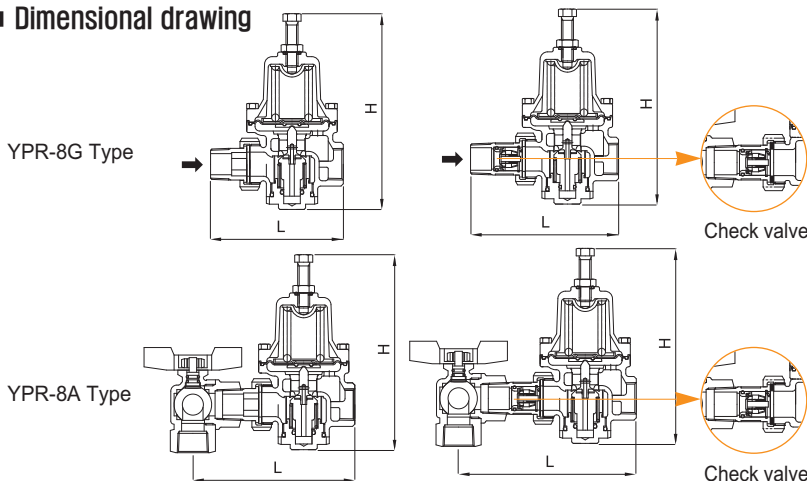

## ■ Flow curve

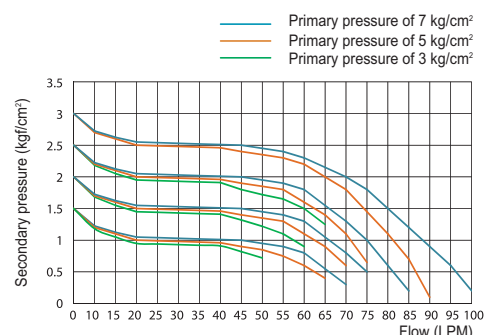

# Type YPR-8N, 8H Pressure Reducing Valve for Heating and Supplying Water for Each Household

Pressure reducing valves that are used to supply water to each household are designed to resolve problems that arise from a pressure imbalance in water supplied to households. They promote user convenience by allowing easy changing of the pipeline direction in accordance with field conditions.



Type YPR-8N



Type YPR-8H

## ■ Dimensional drawing

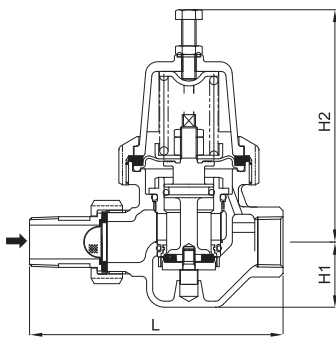

Type YPR-8N

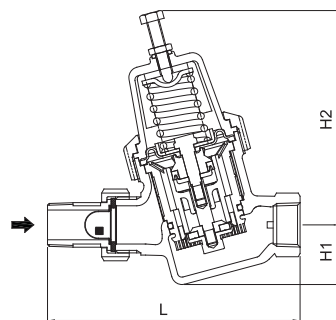

Type YPR-8H

## ■ Features

- Irregular pressures control among households in apartment buildings : it prevents waste of water resources.
- Installation is easy : the product has adopted a union coupling method.
- No additional errors resulting from the idle rotation of the flowmeter; by preventing pressure imbalance in supplied water among households and blocking countercurrents to "low-pressure" households.
- Supplying sufficient flow, based on an appropriate pressure level, even at peak load : its optimal design considers the maximum concurrent usage rate.
- Built-in strainer blocks entry of foreign substances and reduces installation space.
- Precise identification of adjusted pressure.
- Installation space reduction.
- Improvements in cross-sections polishing on the flow path minimize resistance loss and reduce noise.

## ■ Specifications

Type	YPR-8N	YPR-8H
Size	15A(1/2")	
Applicable fluid	Cold/hot water	
Primary pressure	10kgf/cm <sup>2</sup>	
High pressure regulation	0.5~1.5kgf/cm <sup>2</sup> g (for low pressure), 1.5~3.0kgf/cm <sup>2</sup> g(for medium pressure), 3.0~5.0kgf/cm <sup>2</sup> g(for high pressure)	
Applicable fluid temperature	120° C below	
Maximum pressure reduction ratio	10:1	
Minimum differential pressure in the inlet and outlet side of the valve	0.5kgf/cm <sup>2</sup>	
End connection	Inlet	KS PT UNION
	Outlet	KS PT SCREW
Materials	Body	BsC3
	Disc, seat	VITON, SUS
Hydraulic test pressure	15 kgf/cm <sup>2</sup> g	
Optional	Pressure gauge	Check valve, Pressure gauge

▶ Strainer (over 40 Mesh ) installation is required to ahead inlet when valve installing.

## ■ Dimensions

Type	Size	L	H1	H2
YPR-8N	15(1/2")	105	27	96
YPR-8H	15(1/2")	108	28.2	100

## ■ Characteristics chart

### ➤ Flow characteristics chart

#### YPR-8N

Secondary pressure (kgf/cm<sup>2</sup>)

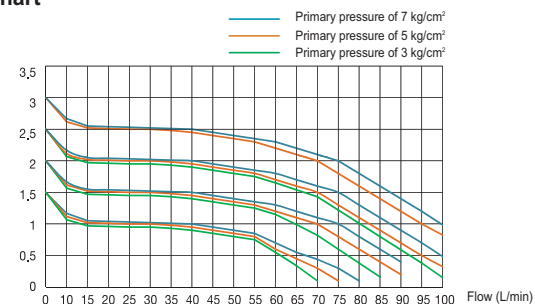

#### YPR-8H

Secondary pressure (kgf/cm<sup>2</sup>)

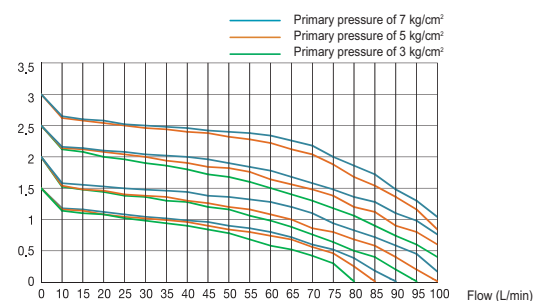

# Type YPR-8E Large Flow Pressure Reducing Valve for Heating and Supplying Water for Each Household

Pressure reducing valves that are used to supply water to each household are designed to resolve problems that arise from a pressure imbalance in water supplied to households. They promote user convenience by allowing easy changing of the pipeline direction in accordance with field conditions.



## ■ Features

- Irregular pressures control among households in apartment buildings : it prevents waste of water resources.
- Installation is easy : the product has adopted a union coupling method.
- Built-in strainer blocks entry of foreign substances and reduces installation space.
- No additional errors resulting from the idle rotation of the flowmeter; by preventing pressure imbalance in supplied water among households and blocking countercurrents to "low-pressure" households.
- Pressure can be adjusted by turning the control section, without using any tools. Pressure adjustment is made even easier by checking of the indicator.
- Supplying sufficient flow, based on an appropriate pressure level, even at peak load : its optimal design considers the maximum concurrent usage rate.
- As a valve with a single-unit cartridge structure, its main components are built in unit form, thereby enabling replacement of inner parts as a unit.
- Easy temporary pipeline construction by using the product's body : no need to install a separate temporary pipeline.
- Improvements in cross-sections polishing on the flow path minimize resistance loss and reduce noise.

## ■ Specifications

Size		15A(1/2")
Applicable fluid		Cold/hot water
Primary pressure		10kgf/cm <sup>2</sup>
Secondary pressure regulating range		1.2~5.0kgf/cm <sup>2</sup>
Applicable fluid temperature		120° C or below
Maximum pressure reduction ratio		10:1
Minimum differential pressure in the inlet and outlet side of the valve		0.5kgf/cm <sup>2</sup>
End connection	Inlet	KS PT UNION
	Outlet	KS PT SCREW
Materials	Body	BC6, BsC3
	Disc, seat	VITON, PSU
Hydraulic test pressure		15 kgf/cm <sup>2</sup> g
Optional		Pressure gauge, Check valve

▶ Strainer (over 40 Mesh ) installation is required to ahead inlet when valve installing.

## ■ Dimensions

(mm)

Type	Size	L	H1	H2
YPR-8E	15(1/2")	108	28.2	128

## ■ Dimensional drawing

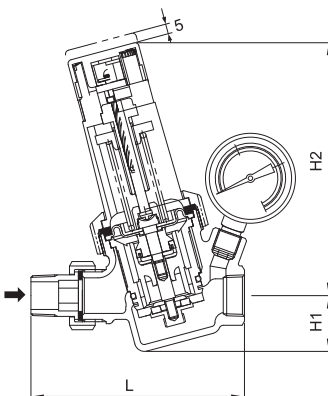

## ■ Characteristics chart

### » Flow characteristics chart

#### YPR-8E

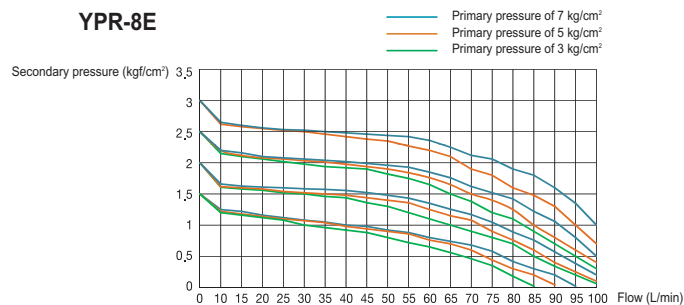

# Type YPR-2A Pressure Reducing Valve for Water

This is a direct operating pressure reducing valve for cold and hot water that can be used for small to large flows, with a small pressure fluctuation range. Used for construction facilities, this valve is employed for pressure control of each level's water supplied by an elevated water tank of a medium or high-rise building; as well as for pressure control of feed water from a directly-coupled pump and other boiler feed water.

## ■ Features

- Outstanding functions for controlling the pressure of water supplied by a building's elevated water tank to each floor.
- Easy to handle : small size and light weight.
- Two ways to install : horizontally or vertically.
- A constant pressure level with only a single adjustment.
- Wide flow range ability : an outstanding level of minimum adjustable flow & adjustable and stable in a wide flow range.
- All parts can be disassembled through the top of the valve : complete repairs even in limited spaces is possible.
- Built-in spring-type orifice that prevents a water hammering action.
- Linear flow pass-through method, which removes noise during operation.

## ■ Specifications

Applicable fluid	Water	
Primary pressure	Maximum 10 kgf/cm <sup>2</sup>	
Secondary pressure regulating range	Outer spring	0.5~3.5kgf/cm <sup>2</sup>
	Inner+outer spring	3~7kgf/cm <sup>2</sup>
Maximum pressure reduction ratio	10:1	
Minimum differential pressure in the inlet and outlet side of the valve	0.5kgf/cm <sup>2</sup>	
Minimum adjustable flow	2~5 liters of water/min	
Fluid temperature	Maximum 5~80° C	
End connection	KS PT SCREW(15~25A), KS 10K FF FLANGE(32~150A)	
Materials	Body	GC200
	Disc, seat	NBR, BC6
Hydraulic test pressure	15 kgf/cm <sup>2</sup>	

- ▶ Multi-step pressure reduction is needed when the cavitation index is 0.5 or lower.
- ▶ Strainer (over 40 Mesh ) installation is required to ahead inlet when valve installing.

## ■ Dimensions

(mm)

Size	L	A	H1	H2	Cv	Weight (kg)
15(1/2")	100	116	50	184	2.1	3.7
20(3/4")	100	116	50	184	2.1	3.7
25(1")	120	142	68	224	3.5	6.9
32(1 1/4")	190	174	81	327	8.0	17.0
40(1 1/2")	190	174	81	327	8.0	17.0
50(2")	190	174	81	327	14	18.6
65(2 1/2")	250	228	100	374	22	36.3
80(3")	250	228	100	374	32	37.4
100(4")	290	250	125	490	48	67.0
150(6")	390	340	165	655	108	150

## ■ Dimensional drawing

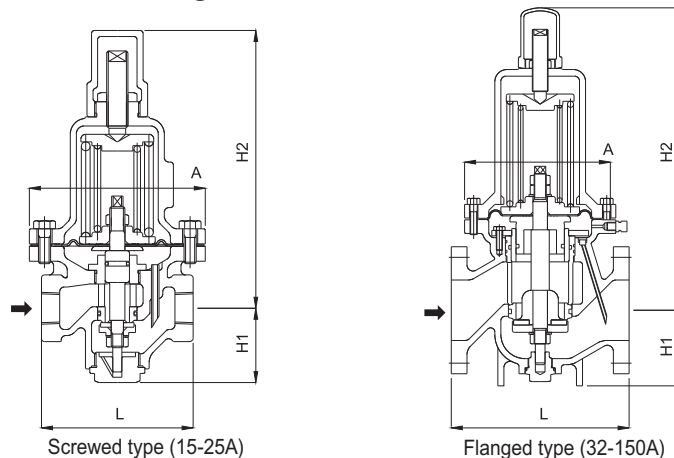

Screwed type



Flanged type

# Type YPR-2A Pressure Reducing valve

## ■ Chart on selecting a size

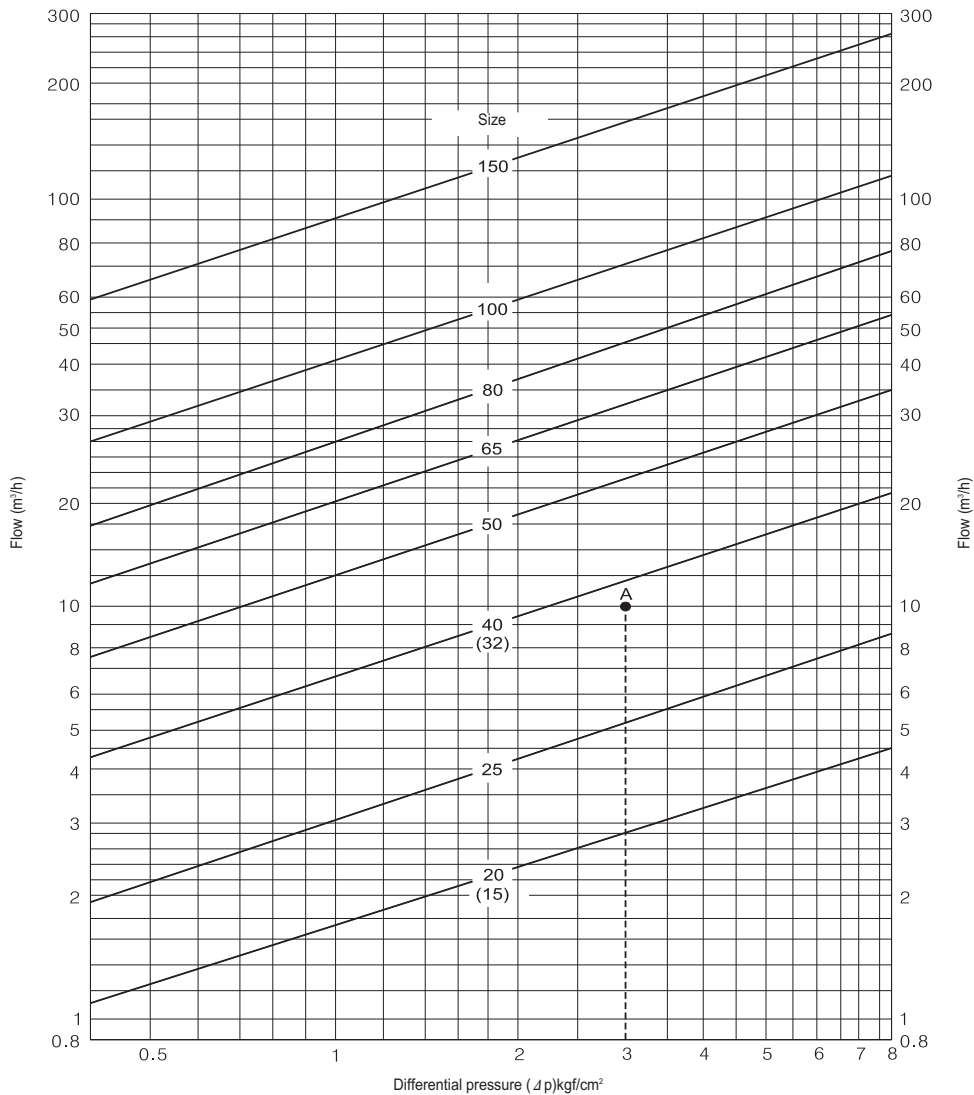

### How to select the size of a valve by the chart

Example) If the primary pressure is 5 kgf/cm<sup>2</sup>g, secondary pressure is 2 kgf/cm<sup>2</sup>g, and flow is 10 cm<sup>3</sup>/h,

- 1) The differential pressure ( $\Delta P = P_1 - P_2$ ) between the primary pressure (5 kgf/cm<sup>2</sup>g) and secondary pressure (2 kgf/cm<sup>2</sup>g) is 3 kgf/cm<sup>2</sup>.
- 2) Determine point "A" by vertically connecting the differential pressure (3 kgf/cm<sup>2</sup>) with the flow (10 cm<sup>3</sup>/h).
- 3) Now that "A" is in between a size of 25 and 40, a size of 40 should be selected.

## ■ Application Diagram (Example)

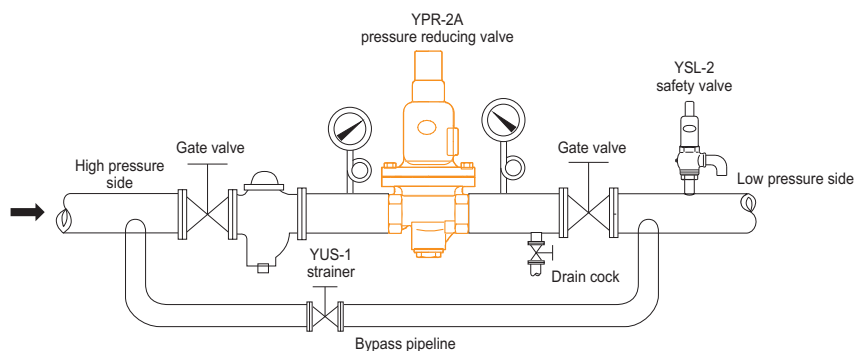

# Type YAWR-1 Pressure Reducing Valve for Water

As a large capacity pressure reducing valve, this product is used for construction facilities, plants, and water-supplying lines for agricultural use. Because the pilot valve has a pressure balance structure, it maintains a constant secondary pressure level, regardless of changes in the primary pressure.



## ■ Features

Special seat structure : it prevents a water hammer when the valve is opened and closed.

## ■ Specifications

Applicable fluid		Clear water, industrial water, agricultural water	
Primary pressure		Maximum 10 kgf/cm <sup>2</sup> g	
Secondary pressure regulating range		Size of 200~250	0.5~7kgf/cm <sup>2</sup> g
		Size of 300~400	0.5~3.5kgf/cm <sup>2</sup> g 3.0~7kgf/cm <sup>2</sup> g
Maximum pressure reduction ratio		10:1	
Minimum differential pressure in the inlet and outlet side of the valve		0.5kgf/cm <sup>2</sup>	
Minimum adjustable flow		10% of rated flow	
Fluid temperature		80° C below	
End connection		KS 10K RF FLANGE	
Materials	Body	GC200	
	Disc, seat	NBR, BC6	
Hydraulic test pressure		15 kgf/cm <sup>2</sup> g	
Optional		Pressure gauge	

- ▶ The primary and secondary pressure gauge is attached upon client's order.
- ▶ The direct operating type (YPR-2A) should be selected for control of small flow.
- ▶ A pipeline needs to be installed in parallel with the direct operating YPR-2A if there is a need for flow control within 10% of the rated flow.
- ▶ Strainer (over 40 Mesh ) installation is required to ahead inlet when valve installing.

## ■ Dimensional drawing

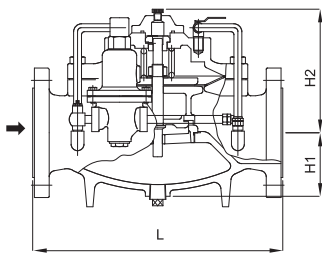

Main valve

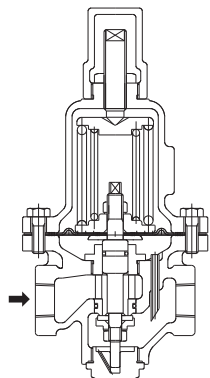

Pilot pressure reducing valve

## ■ Dimensions

(mm)

Size	L	H1	H2	Cv	Weight (kg)
200(8")	640	210	390	640	205
250(10")	740	250	481	1000	440
300(12")	900	290	557	1440	516

- ▶ Made-to-orders are available for valves with a size of 300A or larger.

## ■ Application Diagram (Example)

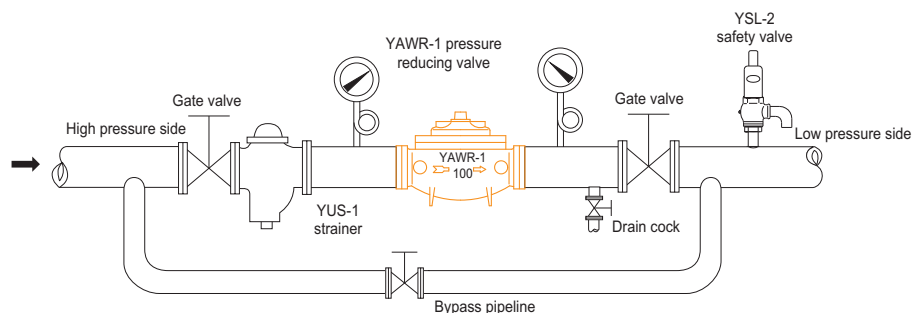

# Type YAWR-1 Pressure Reducing Valve

## ■ Chart on selecting a size

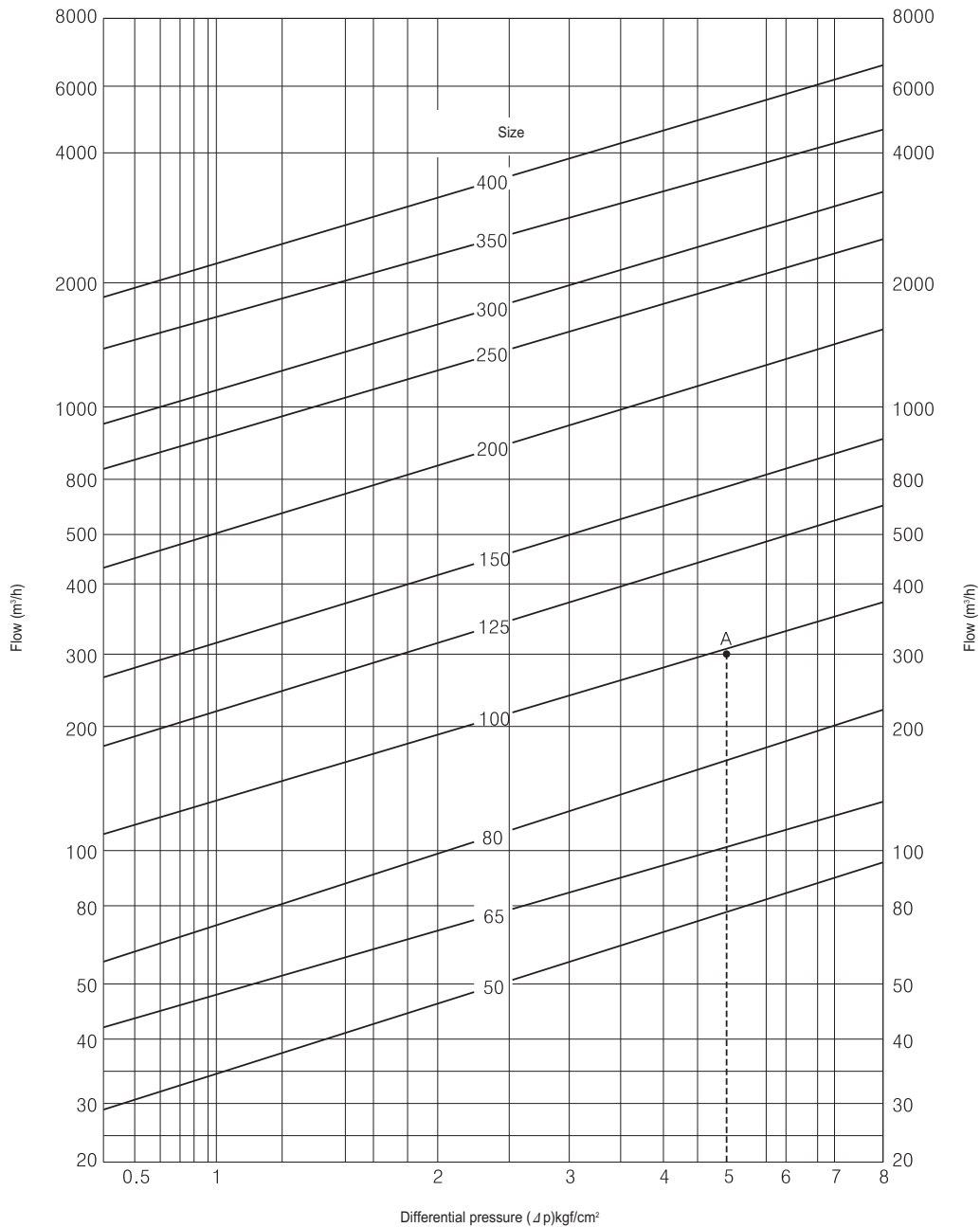

### How to select the size of a valve by the chart

Example) If the primary pressure is 8  $\text{kgf/cm}^2\text{g}$ , secondary pressure is 3  $\text{kgf/cm}^2\text{g}$ , and flow is 30  $\text{cm}^3/\text{h}$ ,

- 1) The differential pressure ( $\Delta P = P_1 - P_2$ ) between the primary pressure (8  $\text{kgf/cm}^2\text{g}$ ) and secondary pressure (3  $\text{kgf/cm}^2\text{g}$ ) is 5  $\text{kgf/cm}^2$ .
- 2) Determine "A" the point of intersection between the differential pressure (5  $\text{kgf/cm}^2$ ) and the flow (30  $\text{cm}^3/\text{h}$ ).
- 3) Now that "A" is in between a size of 80 and 100, a size of 100 should be selected.

# Type YPR-41 Pressure Reducing Valve for Water and Vapor



## ■ Features

- Two ways to install : horizontally or vertically.
- A constant pressure level with only a single adjustment.
- Wide flow range ability : an outstanding level of minimum adjustable flow & adjustable and stable in a wide flow range.
- Also used as a pressure reducing valve for fire fighting equipment.

## ■ Specifications

Applicable fluid		Water, vapor
Primary pressure		Maximum 20 kgf/cm <sup>2</sup> g
Secondary pressure regulating range		0.5~7kgf/cm <sup>2</sup> g (for standard pressure), 7~12kgf/cm <sup>2</sup> g (for medium pressure)
Maximum pressure reduction ratio		10:1
Minimum differential pressure in the inlet and outlet side of the valve		0.5kgf/cm <sup>2</sup>
Fluid temperature		80° C below
End connection		KS 20K RF FLANGE
Materials	Body	SCPH2, STS316
	Disc, seat	NBR, STS
Hydraulic test pressure		35kgf/cm <sup>2</sup>

- ▶ We also manufacture the ANSI flange.
- ▶ Strainer (over 80 Mesh ) installation is required to ahead inlet when valve installing.

## ■ Dimensions

Size	L	H1	H2	Cv	(mm)
15(1/2")	130	62	227	2.1	
20(3/4")	150	65	235	2.1	
25(1")	197	72	264	3.5	
32(1 1/4")	180	83	274	5.5	
40(1 1/2")	235	91	345	8.0	
50(2")	267	107	365	14	
65(2 1/2")	292	132	425	22	
80(3")	318	140	430	32	
100(4")	368	150	535	48	
125(5")	400	175	704	75	
150(6")	473	210	734	108	

- ▶ L(Length) is for 20K.

## ■ Dimensional drawing

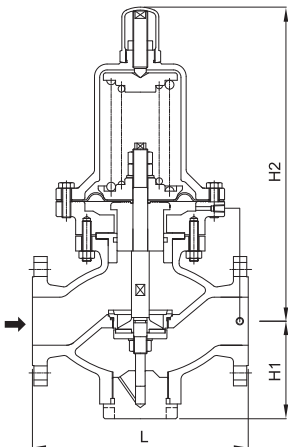

## ■ Application Diagram (Example)

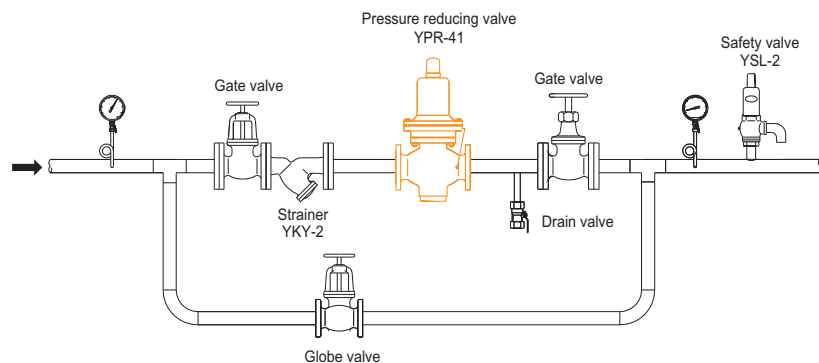

# Type YPR-2W Primary Pressure Regulating Valve for Water

This is a type of relief valve and self-operating regulating valve that discharges excessive pressure resulting from load fluctuations and maintains a constant pressure level in instruments or pipelines. In case of continuous pump operation, changes are made according to fluctuations in the discharge pressure load. It is possible to install this product as a primary pressure regulating valve in the bypass circuit to relieve excessive pressure, and to adjust the discharge pressure to remain constant.



Screwed type



Flanged type

## ■ Features

- Easy to handle : small size and light weight.
- Two ways to install : horizontally or vertically.
- Stable operations : no such issues as hunching or vibration.
- Use of a disc made of special materials inside the valve : No water leakage when the valve is opened and closed.
- Piston-type balance structure : almost no change in the opening pressure resulting from back pressure fluctuations.
- The pressure tank can be used as a relief valve in a pipeline.

## ■ Specifications

Applicable fluid		Water
Primary pressure		0.5~3.5kgf/cm <sup>2</sup> g, 3~7kgf/cm <sup>2</sup> g
Fluid temperature		80° C below
End connection		KS PT SCREW(15~25A), KS 10K RF FLANGE(32~150A)
materials	Body	GC200
	Disc, seat	NBR/BC6
	Diaphragm	NBR
Hydraulic test pressure		15 kgf/cm <sup>2</sup> g

▶ Strainer (over 40 Mesh ) installation is required to ahead inlet when valve installing.

## ■ Dimensions

Size	L	A	H1	H2	Cv	Weight(kg)
15(½")	100	116	50	184	2.1	3.7
20(¾")	100	116	50	184	2.1	3.7
25(1")	120	142	68	224	3.5	6.9
32(1¼")	190	174	81	327	8.0	17
40(1½")	190	174	81	327	8.0	17
50(2")	190	174	81	327	14	18.6
65(2½")	250	228	100	374	22	36.3
80(3")	250	228	100	374	32	37.4
100(4")	290	250	125	490	48	67.0
150(6")	390	340	165	655	108	150

## ■ Dimensional drawing

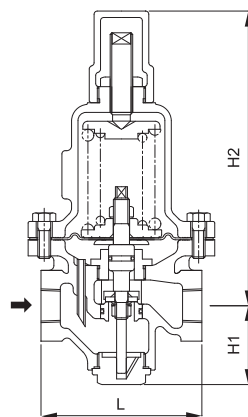

Screwed type(15A~25A)

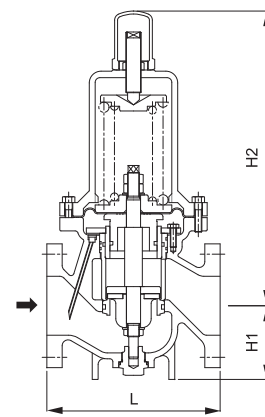

Flanged type(32A~150A)

# Type YPR-2W Primary Pressure Regulating Valve

## ■ Chart on selecting a size

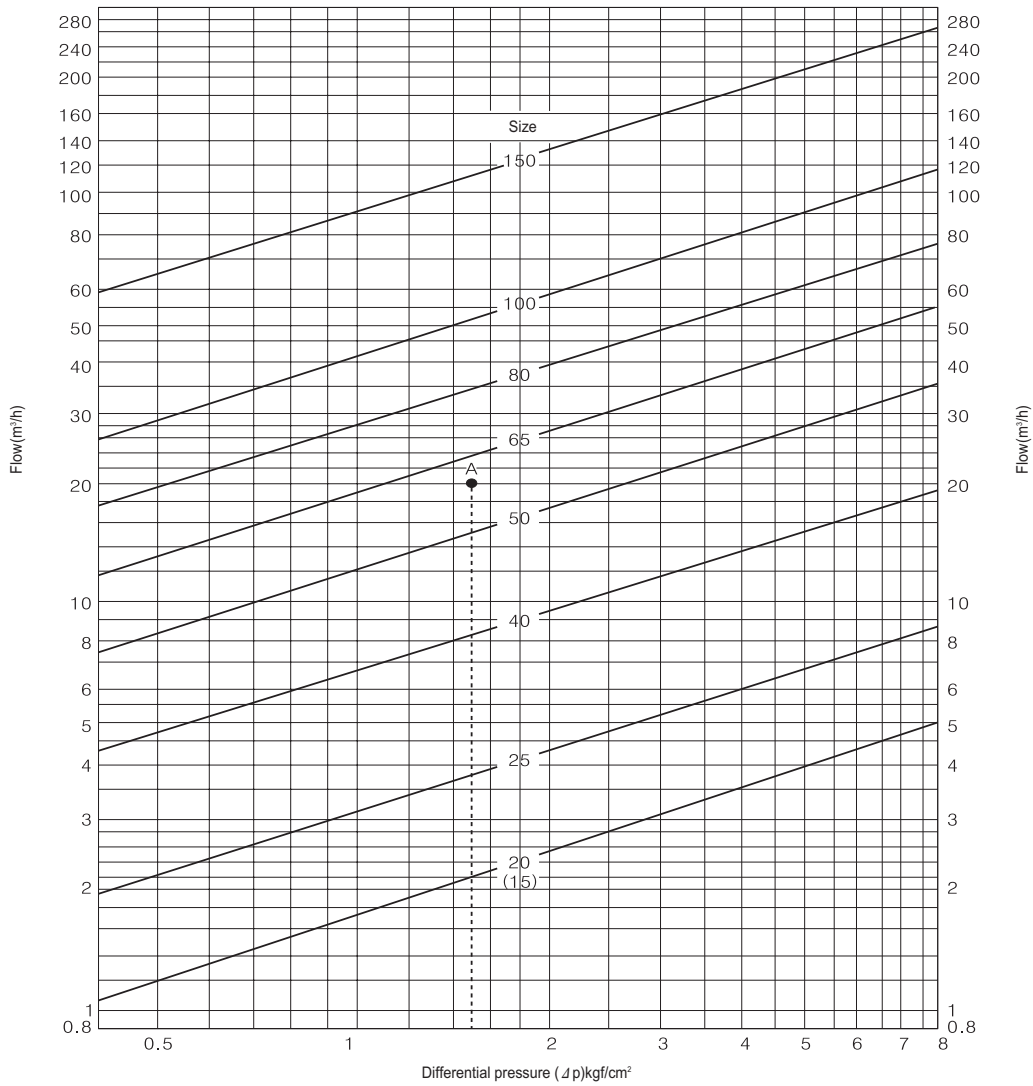

## How to select the size of a valve by the chart

Example) If the opening pressure is 6 kgf/cm<sup>2</sup>g, back pressure is 4.5 kgf/cm<sup>2</sup>g, and flow is 20 m<sup>3</sup>/h,  
 The differential pressure is (ΔP) 6-4.5=1.5 kgf/cm<sup>2</sup>g.  
 Determine "A" where a vertical line from the differential pressure (ΔP) (1.5 kgf/cm<sup>2</sup>g) meets the flow (20 m<sup>3</sup>/h).  
 Now that "A" is in between a size of 50 and 65, the size of the valve should be 65.

## ■ Application Diagram (Example)

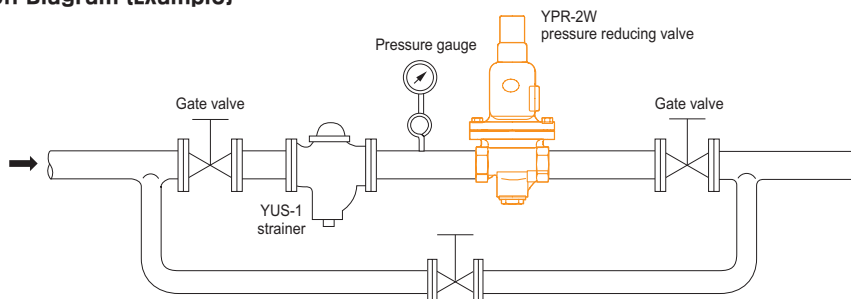

# Type YAWM-1 Primary Pressure Regulating Valve for Water

The type YAWM-1 primary pressure regulating valve combines a main valve and an auxiliary valve. The main valve is operated by setting the pressure of the auxiliary valve. As a bypass valve for large-capacity pumps, it discharges the increased amount of pressure resulting from load fluctuations and ensures that the discharge pressure of a pump remains constant.



## ■ Features

- Based on its auxiliary valve function, it automatically opens and closes valves with a large diameter, without external power supply.
- Pressure balance structure enables it to delicately respond to load fluctuations.
- No water leakage : the diaphragm and disc are made of NBR.
- A speed control valve (needle valve) attached : possible to adjust the opening and closing speed of the main valve.

## ■ Specifications

<b>Applicable fluid</b>		Clear water, industrial water, agricultural water
<b>Primary pressure</b>		200~250mm: 0.5~7kgf/cm <sup>2</sup> 300~400mm: 0.5~5kgf/cm <sup>2</sup>
<b>Fluid temperature</b>		80° C below
<b>End connection</b>		KS 10K RF FLANGE
<b>materials</b>	<b>Body</b>	GC200
	<b>Disc, seat</b>	NBR/BC6
	<b>Diaphragm</b>	NBR
<b>Hydraulic test pressure</b>		15 kgf/cm <sup>2</sup>
<b>Optional</b>		Pressure gauge

▶ Strainer (over 40 Mesh ) installation is required to ahead inlet when valve installing.

## ■ Dimensions

Size	L	H1	H2	Cv	Weight(kg)
200(8")	640	210	390	640	205
250(10")	740	250	481	1000	440
300(12")	900	290	557	1440	516

(mm)

▶ Made-to-orders are available for valves with a size of 300A or larger.

## ■ Cautions to be taken when installing and operating primary pressure regulating valves

1. The control line installed outside the valve is an important part that has a direct effect on valve performance. Care should be taken so that the control line is not damaged from impact or when held by the hand in the process of moving or installing the valve.
2. Install a strainer on the inlet side to prevent valve malfunctions from foreign substances.
3. Settings for the opening/closing speed regulating device that is attached to the main body are made prior to product delivery, so the settings should not be arbitrarily changed.
4. The ball valve, installed on the main body, is for manual operations. Carry out a trial run after closing it.
5. The valve on the load device should be closed when conducting a trial run.

## ■ How to adjust the pressure of primary pressure regulating valves

1. Cut off the stop valve that is connected to the load device.
2. Open the top cap of the pilot valve installed on the main body.
3. Loosen up the fixing nut, and slowly turn the adjustment screw clockwise, while checking the pressure gauge on the valve inlet side, until the desired pressure is obtained.
4. Firmly tighten the fixing nut once the desired pressure is obtained.
5. Check, with sufficient time, if the pressure increases on the pressure gauge on the inlet side.
6. If the pressure on the pressure gauge is fixed at the designated pressure, then the valve is operating normally.

## ■ Dimensional drawing

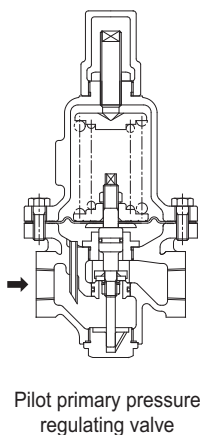
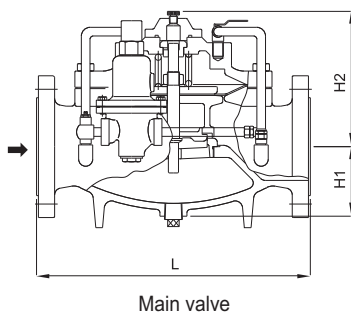

# Type YAWM-1 Primary Pressure Regulating Valve

## ■ Chart on selecting a size

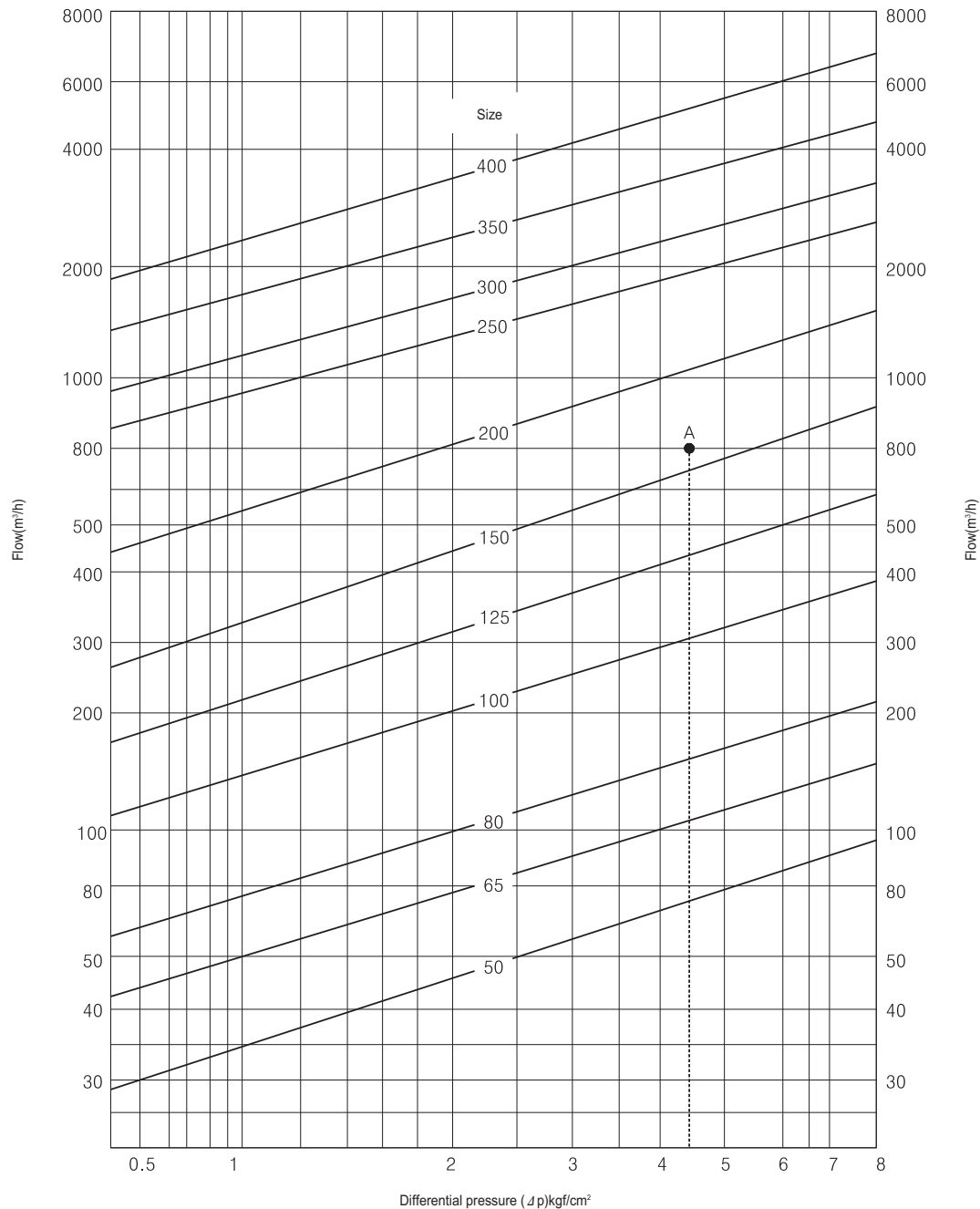

### How to select the size of a valve by the chart

Example) If the opening pressure is 5 kgf/cm<sup>2</sup>g, back pressure is 0.5 kgf/cm<sup>2</sup>g, and flow is 800 m<sup>3</sup>/h,  
 The differential pressure is (ΔP) 5-0.5=4.5 kgf/cm<sup>2</sup>g.  
 Determine "A" where a vertical line from the differential pressure (ΔP) (4.5 kgf/cm<sup>2</sup>g) meets the flow (800 m<sup>3</sup>/h).  
 Now that "A" is in between a size of 150 and 200, the diameter of 200 should be selected.

# Data / Pressure Reducing Valve for Steam

## Terminologies

<b>Primary pressure</b>	Inlet-side pressure within the main body of the pressure reducing valve or pressure within the pipeline on the inlet side that is close to the pressure reducing valve
<b>Secondary pressure</b>	Outlet-side pressure within the main body of the pressure reducing valve or pressure within the pipeline on the outlet side that is close to the pressure reducing valve
<b>Set pressure</b>	Secondary pressure in terms of the minimum adjustable flow
<b>Offset pressure</b>	Difference between the set pressure and secondary pressure that changes when the flow is steadily increased from the minimum adjustable flow to the rated flow, while maintaining a constant primary pressure level
<b>Look up pressure</b>	Difference between the set pressure and the pressure that increases when the secondary valve of the pressure reducing valve is cut off
<b>Minimum adjustable flow</b>	Minimum flow of the pressure reducing valve in a state where a stable flow can be maintained
<b>Rated flow</b>	Maximum flow that can be guaranteed within a certain fixed off-set, while maintaining a constant primary pressure

## Flow characteristics curve

### YPR-100, 100A (Pilot diaphragm type)

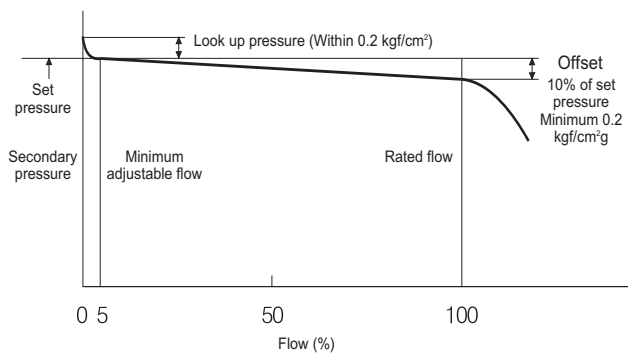

### YPR-1S (Pilot type)

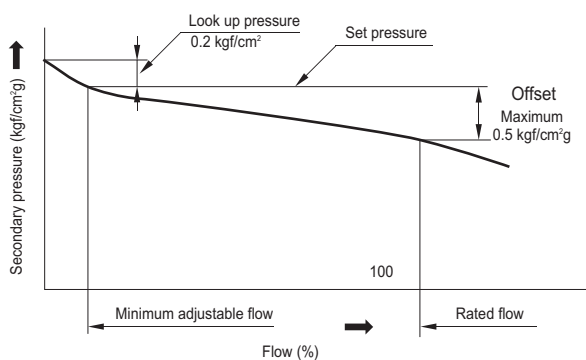

### YPR-2A (Direct operating)

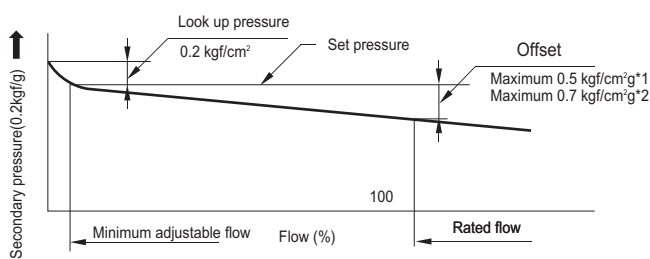

1. Regulating spring range: 0.5~3.5 kgf/cm<sup>2</sup>g
2. Regulating spring range: 3~7 kgf/cm<sup>2</sup>g

## Pressure characteristics curve

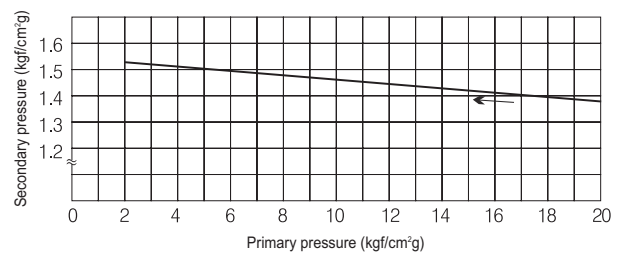

- Assuming that the primary pressure is 17.5 kgf/cm<sup>2</sup>g and the secondary pressure is set to 1.4 kgf/cm<sup>2</sup>g, this shows changes in the secondary pressure when the primary pressure is changed to between 2 and 14 kgf/cm<sup>2</sup>g.

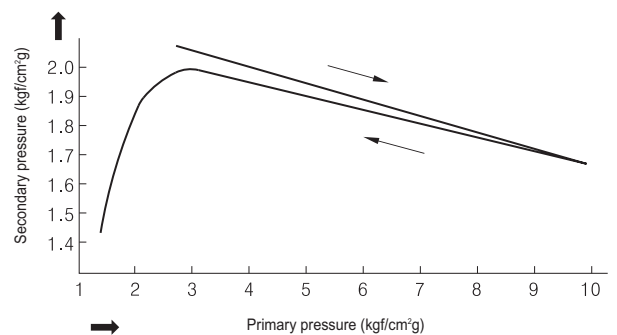

- Assuming that the primary pressure is 3 kgf/cm<sup>2</sup>g and the secondary pressure is set to 2 kgf/cm<sup>2</sup>g, this shows changes in the secondary pressure when the primary pressure is changed from 3 kgf/cm<sup>2</sup>g to 10 kgf/cm<sup>2</sup>g, and then inversely from 10 kgf/cm<sup>2</sup>g to 1.5 kgf/cm<sup>2</sup>g.

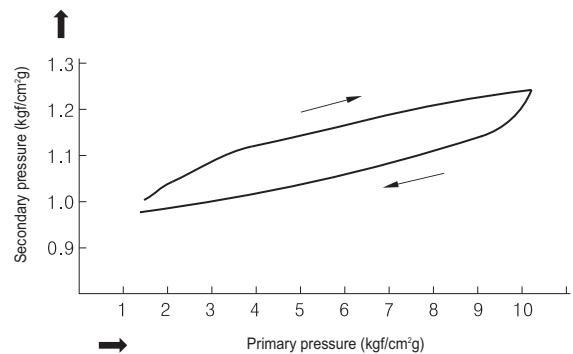

- Assuming that the primary pressure is 1.5 kgf/cm<sup>2</sup>g and the secondary pressure is set to 1 kgf/cm<sup>2</sup>g, this shows changes in the secondary pressure when the primary pressure is increased from 1.5 kgf/cm<sup>2</sup>g to 10 kgf/cm<sup>2</sup>g, and then decreased from 10 kgf/cm<sup>2</sup>g to 1.5 kgf/cm<sup>2</sup>g.

# Data / Pressure Reducing Valve for Steam

## ■ How pressure reducing valves work

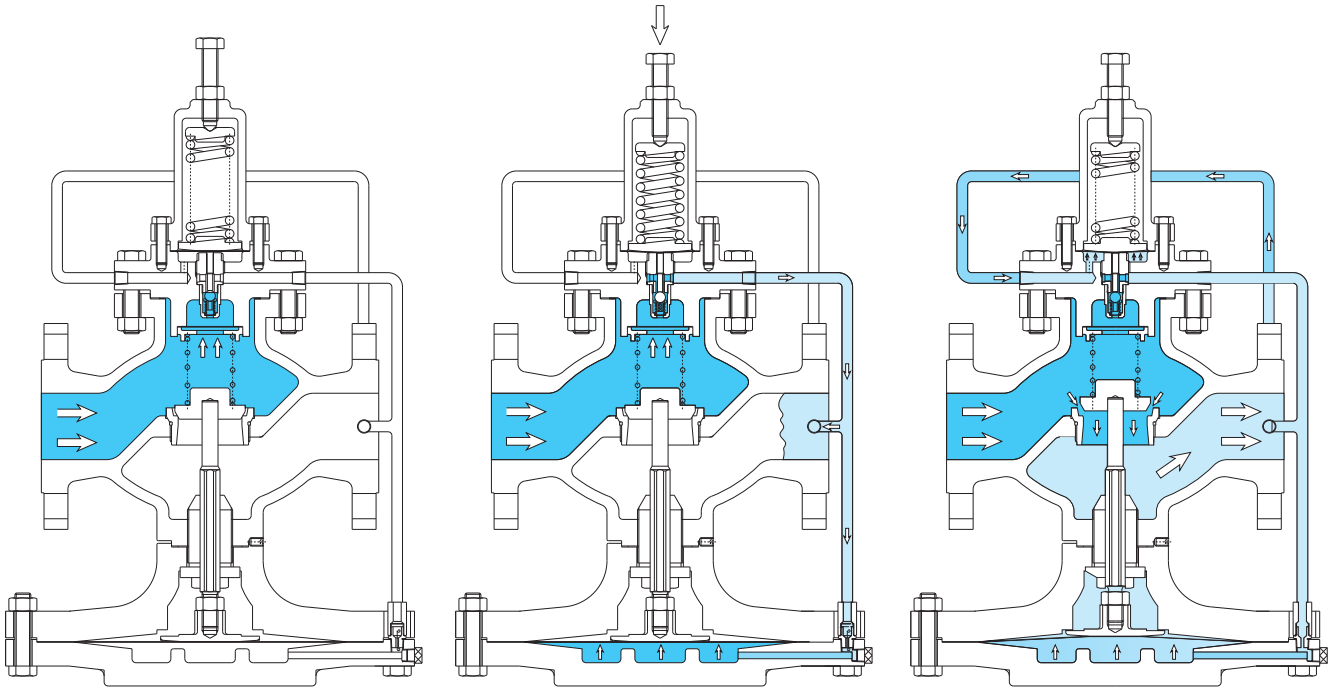

- ① The secondary pressure, which was reduced through the main valve, actuates the pilot diaphragm through the pressure sensing tube.
- ② This reduced secondary pressure adjusts the secondary pressure by responding to the force of the pressure regulating spring that is installed on the upper part of the pilot diaphragm.

- ① When the secondary pressure drops, the force of the pressure regulating spring becomes bigger than the force of the lower part of the pilot diaphragm, resulting in the diaphragm pushing downwards to open the pilot valve.
- ② When the pilot valve opens, the steam of the primary goes through the pressure regulating tube and reaches the lower part of the main diaphragm located at the lower end of the pressure reducing valve's body.
- ③ The main diaphragm overcomes the pressure of the return spring and opens the main valve. Steam is supplied to the secondary and thus the secondary pressure is adjusted.

- ① When the secondary pressure rises, it actuates the pilot diaphragm, thus adjusting the opening percentage of the pilot valve. The return spring pushes the main valve, and the steam of the lower part of the main diaphragm moves along the pipe and is discharged through the orifice.
- ② The steam pressure and pressure of the lower part of the main diaphragm adjusts the opening degree of the main valve according to load fluctuations, based on a balance maintained by the opening percentage of the pilot valve. This is how a constant secondary pressure level is maintained immediately after pressure changes or load fluctuations.

## ■ Notes for selecting a size

1. When selecting a size, make room for an additional 10 to 20% of flow, in consideration of such matters as pressure loss. There is especially a need to make substantial room when the pressure reduction ratio is high or the set pressure is 1 kgf/cm<sup>2</sup>g or less.
2. The secondary pressure of a pressure reducing valve changes according to fluctuations in the primary pressure as well as the flow. There is a need to determine a set pressure after considering the look up pressure and offset, and then select a size. (Refer to the pressure and flow characteristics curves.)
3. When the primary and secondary pressures are not constant, and change within a certain range, there is a need to select a size based on the primary and secondary pressures that have the minimum differential pressure.
4. It is only natural that the flow becomes smaller when the size is too small. There are also issues when the flow is substantially bigger than needed. Such issues include hunching, chattering, and abnormal abrasion. Also, the minimum adjustable flow of a pressure reducing valve is 5% of the rated flow. It is recommended to avoid selecting a size that is based on this flow or smaller. When there are severe changes in summer and winter, attach two pressure reducing valves, one big and one small, and use the valve appropriate for the needed flow.

# Data / Pressure Reducing Valve for Steam

## ■ Size of pipeline from a pressure reducing valve's inlet to outlet

Though the size of a pressure reducing valve can be determined based on the valve's size selection chart or Cv formula, the size of the pipeline from the pressure reducing valve's inlet to outlet should be determined based on the fluid's standard flow velocity. If the size of the pipeline is too small, it is affected by the flow of the fluid, resulting in excessive pipeline pressure, or a negative effect on the pipeline. As such, there is a need to sufficiently consider the standard flow velocity when selecting the pipeline size.

### » Standard flow velocity chart for steam

Category	Steam type	Standard flow velocity
Small pipeline	Saturated steam (2~5 kgf/cm <sup>2</sup> g)	15~20
	Saturated steam (5~15kgf/cm <sup>2</sup> g)	20~30
Steam main	Saturated steam	20~30
	Superheated steam	30~40

## ■ Standard piping diagram

### » For steam

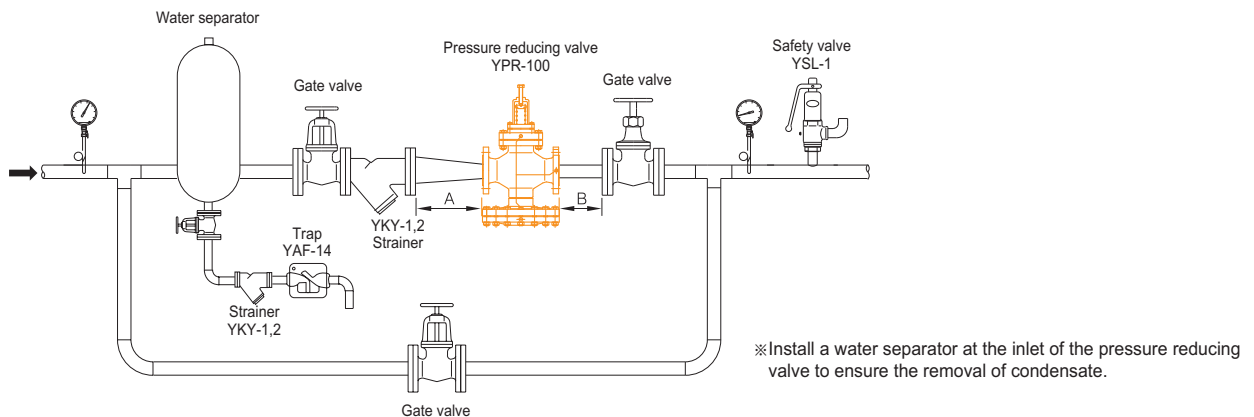

### » Dimensions

Size of valve	Length of straight section	
	A(mm)	B(mm)
15~40	400	900
50~100	900	1,500
125~200	1,200	2,500

## ■ For liquid

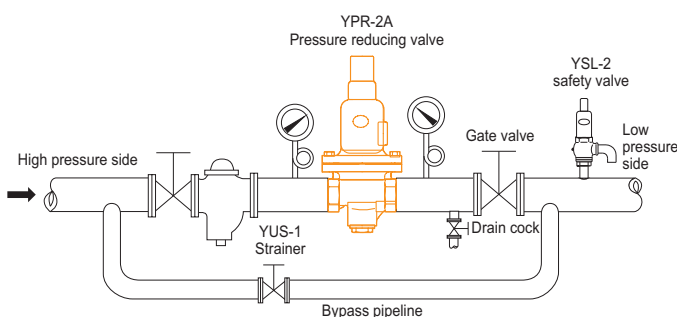

## ■ For air

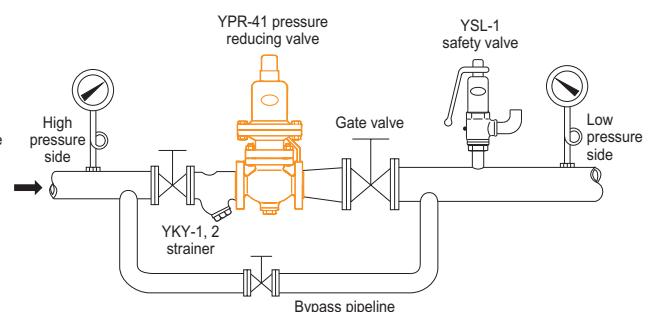

# Data / Pressure Reducing Valve for Steam

## ■ Selection of a secondary safety valve of a pressure reducing valve

A safety valve should be attached to the secondary of a pressure reducing valve to protect equipment from a rise in pressure resulting from a breakdown of the pressure reducing valve. (Installation of safety valves is for an alarming purpose, and is irrelevant to laws and regulations.)

### 1. Set pressure of safety valve

A set pressure of a safety valve should be chosen based on the following table, in consideration of the look up pressure of the pressure reducing valve and static pressure of the safety valve.

Set pressure of pressure reducing valve (kgf/cm <sup>2</sup> g)	Set pressure of safety valve (kgf/cm <sup>2</sup> g)
1 or less	Set pressure of pressure reducing valve + 0.5 or more
More than 1 and less than 4	Set pressure of pressure reducing valve + 0.8 or more
4 or more and less than 6	Set pressure of pressure reducing valve + 1.0 or more
6 or more and 8 or less	Set pressure of pressure reducing valve + 1.2 or more

### 2. Flow table of safety valve

A safety valve that is approximately 10% of the maximum flow of the pressure reducing valve should be chosen, unless there are special instructions to do otherwise.

#### » Saturated steam

(kg/h)

Size \ P	0.5	1	2	3	4	5	6	7	8	9	10
15(1/2")	9.93	13.0	19.3	25.4	31.5	37.5	43.4	49.3	55.2	61.0	66.8
20(3/4")	16.5	21.8	32.2	42.4	52.5	62.6	72.5	82.3	92.1	101	111
25(1")	28.9	38.2	56.3	74.2	91.9	109	126	143	161	178	194
40(1 1/2")	66.5	87.4	129	169	210	250	290	329	368	407	446
50(2")	107	142	209	276	341	406	471	535	599	662	725

#### » Air

(kg/h)

Size \ P	0.5	1	2	3	4	5	6	7	8	9	10
15(1/2")	14.4	19.2	28.8	38.4	48.1	57.7	67.3	76.9	86.6	96.2	105
20(3/4")	24.0	32.1	48.1	64.2	80.3	96.3	112	128	144	160	176
25(1")	42.0	56.1	84.2	112	140	168	196	224	252	280	308
40(1 1/2")	96.3	128	192	256	321	385	449	513	577	642	706
50(2")	156	208	313	417	521	626	730	834	939	1043	1147

## 3. Safety valve

### » Specifications

Applicable fluid	Steam, air, liquid, vapor	
Set pressure range	0.35~10kgf/cm <sup>2</sup> g	
Fluid temperature	220℃ or below	
End connection	KS PT Screw	
Material	Body	GC
	Disc, seat	STS
Hydraulic test pressure	15 kgf/cm <sup>2</sup> g	

### » Dimensions

(mm)

Size	L1	L2	YSL-1	YSL-2
			H1	H2
15(1/2")	40	41	127	112
20(3/4")	50	50	137	122
25(1")	55	60	162	148
40(1 1/2")	70	75	230	216
50(2")	80	80	257	245

# Data / Pressure Reducing Valve for Steam

## ■ Cautions for installation and usage

1. Vertically install the pressure reducing valve on a horizontal pipeline.
2. Install a straight pipeline at the inlet and outlet of the pressure reducing valve, as shown in the standard piping example, and also install a strainer, a safety valve, a pressure gauge, and a bypass pipeline. Install a globe valve on the inlet side. In case of leakage and repair after installment of a gate valve, the pressure reducing valve should not be disassembled.
3. A strainer and a safety valve (relief valve) manufactured by Samyang should be used.

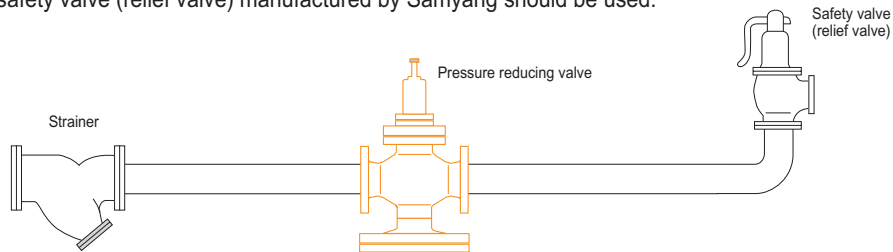

### 4. Length of secondary pipeline

If an electronic valve or other valve for rapid opening and closing is installed on the secondary of a pressure reducing valve, have it located as far away from the pressure reducing valve as possible. Failure to do so may cause, in some cases, noises and vibrations.

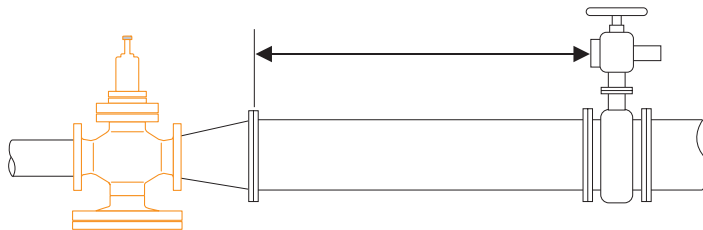

### 5. Inspection and disassembling space

To enable disassembling and inspection, secure enough space above the center of the pipeline that is at least 3 times the H2 length of the pressure reducing valve dimensions; and below the center of the pipeline that is at least 5 times the H1 length of the dimensions. (Refer to pressure reducing valve dimensions.)

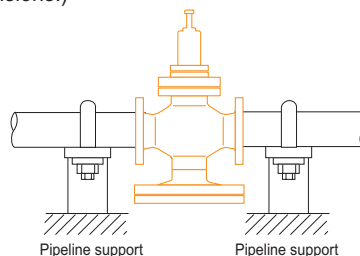

### 6. Pipeline support

Set or support the pipeline at the inlet and outlet of a pressure reducing valve so that the gravity or thermal stress of the pipeline is not directly inflicted upon the pressure reducing valve.

### 7. Pipeline cleaning

In new pipelines, most pressure reducing valve breakdowns are caused by foreign substances. Before having steam pass through the pressure reducing valve, completely remove foreign substances within the pipeline by blowing them out through the bypass.

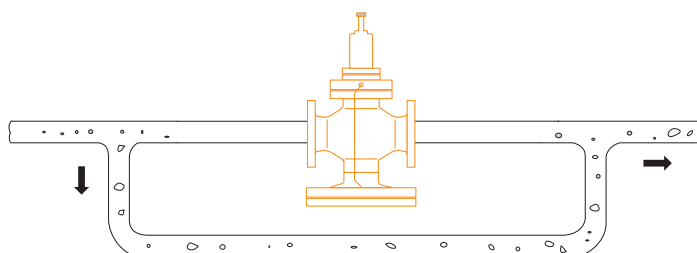

# Data / Pressure Reducing Valve for Steam

## 8. Parallel use

There are cases where two pressure reducing valves are used in parallel because of the lack of flow with one valve. In case of parallel use, pressure reducing valves are self-operated valves, and thus there is a difference in pressure sensitivity. This is why the set pressure needs to be different. It is also recommended that each valve be used independently as much as possible.

### » Example of a bad case

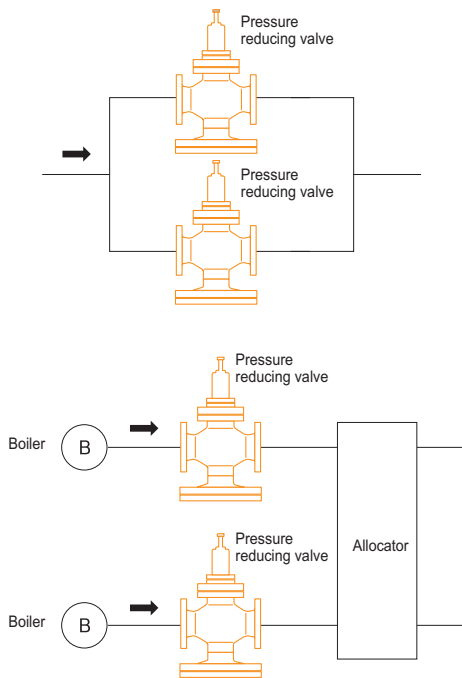

### » Good example

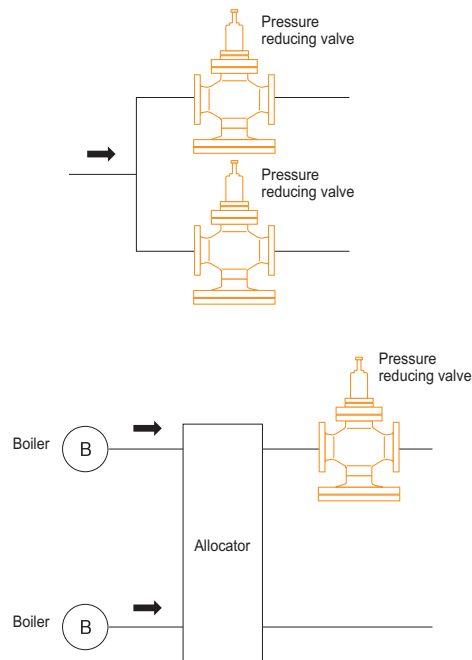

## 9. Measure against condensate

Hunching or vibration can occur if condensate gets into a pressure reducing valve. This is why there is a need to adopt a piping method that blocks condensate entry or to remove condensate.

### » Good example

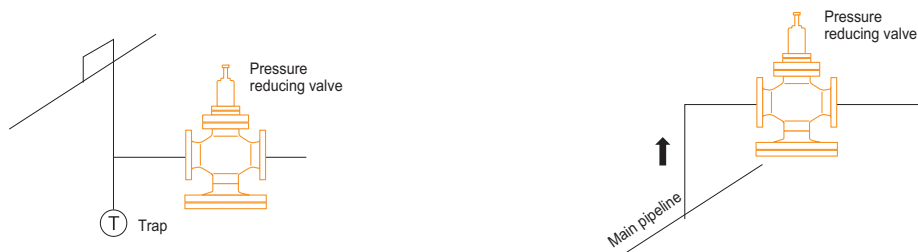

### » Example of a bad case



# Data / Pressure Reducing Valve for Steam

## ■ How to select a size of a pressure reducing valve using the Cv calculation formula

Fluid	Pressure condition	Formula	Symbols
Steam	When, $\Delta P < \frac{P_1}{2}$	$Cv = \frac{WK}{13.67\sqrt{\Delta P(P_1+P_2)}}$	W = Maximum flow (kg/h) V = Maximum flow (m <sup>3</sup> /h) P <sub>1</sub> = Primary pressure [kgf/cm <sup>2</sup> (abs)] P <sub>2</sub> = Secondary pressure [kgf/cm <sup>2</sup> (abs)] $\Delta P = P_1 - P_2$ kgf/cm <sup>2</sup> K = 1+(0.0013 x Degree of superheat °C) Q = Maximum flow (Nm <sup>3</sup> /h): When in standard state (15° C, 760 mmHg abs) G = Specific gravity (Air=1, Water=1) T = Temperature(°C)
	When, $\Delta P \geq \frac{P_1}{2}$	$Cv = \frac{WK}{11.9P_1}$	
Vapor	When, $\Delta P < \frac{P_1}{2}$	$Cv = \frac{Q}{287} \sqrt{\frac{G(273+t)}{\Delta P(P_1+P_2)}}$	
	When, $\Delta P \geq \frac{P_1}{2}$	$Cv = \frac{Q\sqrt{G(273+t)}}{249P_1}$	
Liquid		$Cv = \frac{1.167 \times V\sqrt{G}}{\sqrt{P_1 - P_2}}$	

## ■ Example of calculation of Cv value (for steam)

Assuming that the primary pressure is 4.5 kgf/cm<sup>2</sup>g, secondary pressure is 2 kgf/cm<sup>2</sup>g, and saturated steam flow is 600 kg/h, the following shows how to select a size of a pressure reducing valve using the Cv calculation formula.

$$P_1 = 4.5 + 1 = 5.5 \text{ kgf/cm}^2(\text{abs})$$

$$P_2 = 2 + 1 = 3 \text{ kgf/cm}^2(\text{abs})$$

$$\Delta P = 5.5 - 3 = 2.5 \text{ kgf/cm}^2$$

$\frac{P_1}{2} = 2.75 \text{ kgf/cm}^2$  and  $\Delta P < \frac{P_1}{2}$ , use the following formula:

$$Cv = \frac{WK}{13.67\sqrt{\Delta P(P_1+P_2)}} \text{ use the formula}$$

$$\therefore Cv = \frac{600 \times 1}{13.67\sqrt{2.5(5.5+3)}} \quad 9.5$$

(The K value is saturated steam. Its value is 1 since the degree of superheat is 0.)

The resulting Cv value of 9.5 is in between 40 and 50 in the steam category of the table below (YPR-1S). There is a need to choose 50 to ensure that there is no harmful stress on the pipeline. The same value will be obtained when using the pressure reducing valve's size selection table (Page 4) to determine a valve's size, based on the conditions above.

## ■ Caution during installation

1. Align the arrow direction of the valve's body and the fluid's direction, and thus install the valve horizontally on the pipeline.
2. Install the straight sections at the inlet and outlet of the pressure reducing valve, and install a strainer, a safety valve, a pressure gauge, and a bypass line. Install a globe valve on the inlet side. Install a gate valve on both the inlet and outlet sides, and a globe valve on the bypass line.
3. If an electronic valve or other valve for rapid opening and closing is installed on the secondary of a pressure reducing valve, have it located as far away from the pressure reducing valve as possible.
4. In new pipelines, most pressure reducing valve breakdowns are caused by foreign substances within the pipeline. Before having steam pass through the pressure reducing valve, completely remove foreign substances within the pipeline by blowing them out through the bypass.
5. Hunching or vibration can occur if condensate gets into a pressure reducing valve. This is why there is a need to install a water separator on the inlet side of the pressure reducing valve to remove condensate.

## ■ Cv chart for each type of pressure reducing valve

Category Size	For steam			For water			For vapor
	YPR-100	YPR-1S	YPR-50	YAWR-1	YPR-2A	YPR-41	YPR-41
15(1/2")	5	1	0.8	-	2.1	2.1	2.1
20(3/4")	7.2	2.5	0.8	-	2.1	2.1	2.1
25(1")	10.9	4	1	-	3.5	3.5	3.5
32(1 1/4")	14.3	6.5	-	-	8	3.5	3.5
40(1 1/2")	18.8	9	-	-	8	8	8
50(2")	32	16	-	40	14	14	14
65(2 1/2")	60	25	-	62.5	22	22	22
80(3")	78	36	-	90	32	32	32
100(4")	120	100	-	160	48	48	48
125(5")	160	144	-	250	-	75	75
150(6")	245	256	-	360	108	108	108
200(8")	-	-	-	640	-	-	-
250(10")	-	-	-	1000	-	-	-
300(12")	-	-	-	1440	-	-	-
350(14")	-	-	-	1960	-	-	-
400(16")	-	-	-	2560	-	-	-

# Data / Pressure Reducing Valve for Water

## ■ How pressure reducing valves work

### 1. Importance of pressure reducing valves

- If water pressure is inappropriate in a water supply and distribution piping system, use of water becomes inconvenient and water facilities cannot be efficiently used.
- If water pressure is too high: Increased water supply, increased leakage, and abrasion of the connected sections of the water distribution piping system and reduced life span of the system
  - If water pressure is too low: Short flow supply, resulting from lack of supply pressure

### 2. Types of pressure reducing valves

#### 1) Direct operating type

It regulates the water pressure on the outlet side by operating the valve based on the spring's elasticity and outlet-side water pressure.

##### -How it works-

- ① Outlet-side water pressure < Spring force
- ② Valve opens
- ③ Water on the inlet side flows to the outlet side
- ④ Outlet-side water pressure > Spring force  
(If only a small amount of water is used or is not used at all on the inlet side)
- ⑤ Valve closes
- ⑥ The balance between the outlet side and spring force maintains a certain set pressure level

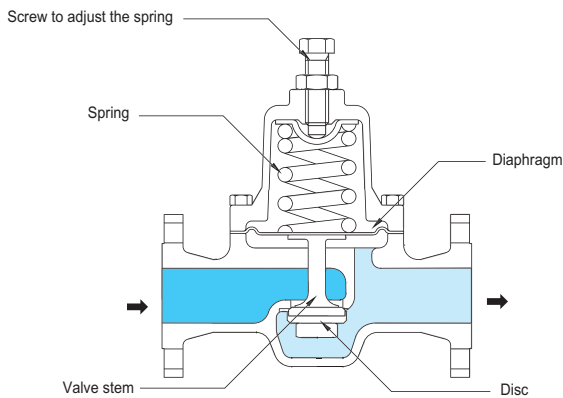

Dimensional drawing of direct operating type pressure reducing valve

#### 2) Pilot type

A main valve and an auxiliary valve exist as a set, and the auxiliary valve is referred to as the pilot. The auxiliary valve is a small, direct operating pressure reducing valve. The valve opens and closes based on the water pressure on the outlet side and the spring force. Water that passes through activates the main valve.

##### -How it works-

- ① Outlet-side water pressure < Spring force
- ② The auxiliary valve opens
- ③ Water from the main valve passes through points D, E, and F, and flows in the direction of point G
- ④ Water at A, the upper part of the main valve diaphragm, flows in the direction of point D (If only a small amount of water is used or is not used at all on the inlet side)
- ⑤ Volume of water that was filled up at A goes down
- ⑥ The diaphragm moves upwards
- ⑦ The valve closes
- ⑧ Water on the inlet side flows to the outlet side
- ⑨ Hydro pressure on the outlet side rises
- ⑩ Hydro pressure on the outlet side of the pilot pushes the diaphragm in the direction of the spring, resulting in the pilot closing
- ⑪ Flow from point F to point G is cut off
- ⑫ Water on the inlet side of the main valve passes through points C and D and moves to point A
- ⑬ The diaphragm is pushed in the disc direction, and the valve closes
- ⑭ The set pressure on the outlet side is maintained through the repetition of the process above

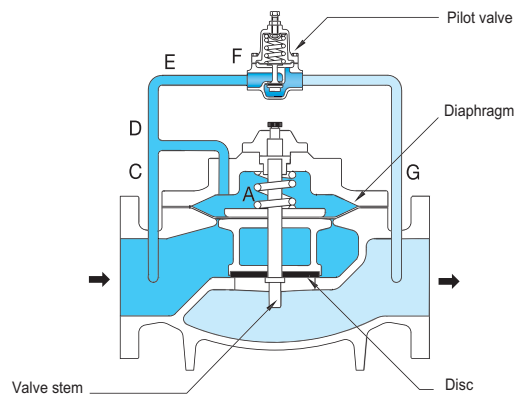

Dimensional drawing of pilot type pressure reducing valve

# Data / Pressure Reducing Valve for Heating and Supplying Water for Each Household

## ■ Required information when placing an order

- Model name • Type of fluid • Pressure conditions (Maximum pressure used, set pressure  $\text{kgf/cm}^2$ ) • Maximum temperature used
- Pipeline diameter and end connection • Maximum flow used (LPM) • Order specifications (Valve features)

## ■ Secondary pressure adjustment method

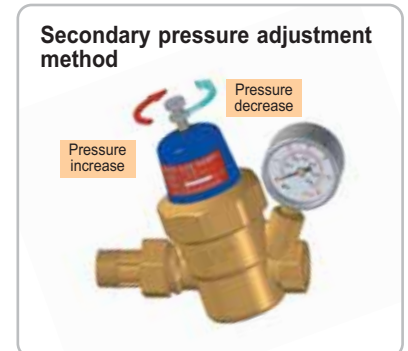
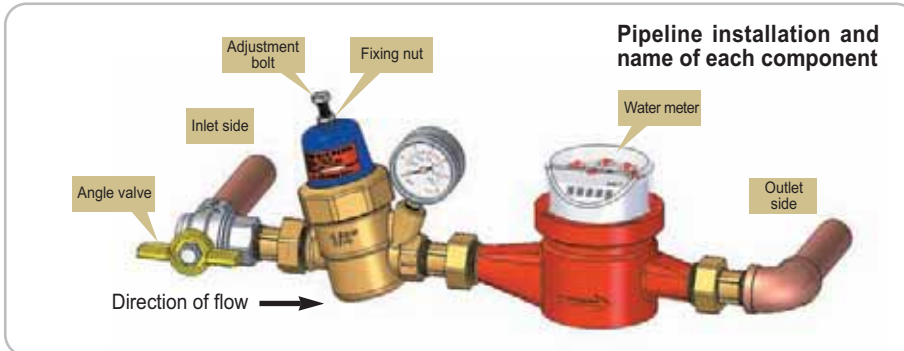

- The secondary pressure of a pressure reducing valve is adjusted according to field conditions before the product is delivered to the customer, thereby eliminating the need for the customer to adjust the secondary pressure. However, it may be necessary to adjust the secondary pressure when there is a design or capacity change in the system.
- With regards to a pressure reducing valve for water supply, if a pressure gauge is not attached to the valve body (optional) or a pressure gauge is not installed at the outlet of the valve, the secondary pressure (set pressure) cannot be accurately adjusted. It is therefore recommended that the secondary pressure not be adjusted arbitrarily, if possible.



### ➤ YPR-8E

1. Pull the top pressure adjustment handle upwards.
2. Open the angle valve (cut-off valve) on the inlet side to raise the inlet-side pressure.
3. Close the water tap on the outlet side (cut-off valve). Slowly turn the pressure adjustment handle clockwise (counter clockwise), while looking at the outlet pressure gauge. The secondary pressure will go up (down).
5. Check if the secondary pressure (set pressure) is correct, while opening and closing the water tap on the outlet side (cut-off valve).
6. Once pressure adjustment is completed, push the pressure adjustment handle to prevent arbitrary adjustment of pressure by other personnel.



### ➤ YPR-8N, 8H

1. Loosen the fixing nut installed on the adjustment bolt on the top.
2. Open the angle valve on the inlet side (cut-off valve) to raise the inlet-side pressure.
3. Close the water tap on the outlet side (cut-off valve). Slowly turn the adjustment bolt clockwise (counter clockwise), while looking at the outlet pressure gauge. The secondary pressure will go up (down).
4. Check if the secondary pressure (set pressure) is correct, while opening and closing the water tap on the outlet side (cut-off valve).
5. Once pressure adjustment is completed, tighten the fixing nut to prevent arbitrary adjustment of pressure by other personnel.

## ■ Installation and maintenance

The following should be paid attention to when handling the product so that it can be operated at maximum performance.

- Do not cause impact on the product.
- Take special care so that foreign substances do not get inside the product.
- Completely remove scales, sand, dregs, etc. when attaching the product to a pipeline.
- If possible, install the product at a location that allows easy maintenance and inspection.
- Regularly clean the strainer that is attached to the pressure reducing valve to prevent malfunctions due to foreign substances.
- A malfunction of the pressure reducing valve would entail a water hammer, attributable to an abnormal pressure buildup inside the pipeline, as well as damage or shortening of the life span of other instruments located at the valve outlet. This is why there is a need to periodically check to see if the secondary pressure remains constant.
- There is no need to adjust the set pressure, since it is fully checked at the plant prior to product delivery.

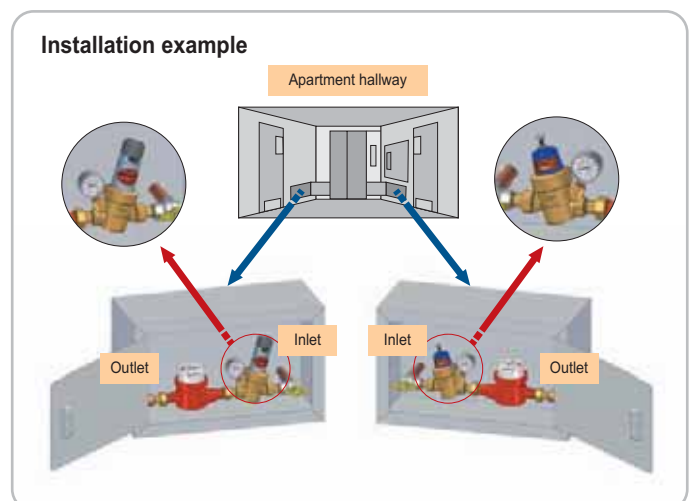

# Safety Valve

## 2

### Safety Valve



Safety valves protect systems from excessive pressure usually from air or steam generators. They instantaneously release pressure when the fluid's pressure exceeds a set value.

#### Full bore type

Type	Size	Applicable fluid	Applicable pressure (kgf/cm <sup>2</sup> g)	Materials		End connection	Page
				Body	Disc, seat		
YSF-1	25(1")~80(3")	Steam, air	1~10	GC200	STS	KS 10K RF FLANGE	52
YSF-2		Liquid					
YSF-3	25(1")~200(8")	Steam, air	1~30	SCPH2		KS 10, 20, 30K RF FLANGE	53
YSF-4		Liquid					
YSF-5	20(3/4")~50(2")	Steam, air	1~10	GC200		KS PT SCREW	54
YSF-6		Liquid					
YSF-3(open)	25(1")~200(8")	Steam	1~30	SCPH2	KS 10, 20, 30K RF FLANGE	55	



#### Low lift type

Type	Size	Applicable fluid	Applicable pressure (kgf/cm <sup>2</sup> g)	Materials		End connection	Page
				Body	Disc, seat		
YSL-1	15(1/2")~50(2")	Steam, air	0.35~10	GC200	STS	KS PT SCREW	56
YSL-2		Water					

#### Pump relief type

Type	Size	Applicable fluid	Applicable pressure (kgf/cm <sup>2</sup> g)	Materials		End connection	Page
				Body	Disc, seat		
YRV-1	25(1")~80(3")	Water	1.0~10	GC200	STS	KS 10K RF FLANGE	57
YRV-2			1.0~30	SCPH2		KS 10, 20, 30K RF FLANGE	

#### Types of caps

<b>Lever type</b>		Mainly for steam, this cap is used to check regular operation.	<b>Cap type</b>		Used for gas-tight on the exhaust side, this cap is a standard type for liquid and vapor.
-------------------	---	--	-----------------	---	---

# Type YSF-1, 2 Safety Valve (Full Bore Type) Steam Boiler Pressure Vessel

2



Type YSF-1



Type YSF-2

## ■ Features

- Simple structure and outstanding performance.
- Superb performance, followed by strict quality control procedure.
- High impact resistance and good abrasion resistance : The disc and seat are stainless steel welded with satellite.
- Test lever attached : Periodical performance inspections can be conducted.
- Approval from the Korea Occupational Safety and Health Agency (KOSHA).

## ■ Specifications

Type		YSF-1	YSF-2
Test lever		Yes	Optional
Applicable fluid		Steam, air	Liquid
Set pressure range		1~10kgf/cm <sup>2</sup> g	
Fluid temperature		220° C below	
End connection	Inlet	KS B 6216 10K RF FLANGE	
	Outlet	KS B 1511 10K FF FLANGE	
Material	Body	GC200	
	Disc, seat	STS (Stellite welding)	
Hydraulic test pressure		15kgf/cm <sup>2</sup> g	

▶ The JIS and ANSI flanges are available by made-to-orders.

## ■ Dimensions

(mm)

Size Inlet X Outlet	Seat diameter	Throat diameter	Throat area	Lift	Face to Face		Height(h)		Flange thickness	Weight(kg)	
					L1	L2	YSF-1	YSF-2		t	YSF-1
25(1")X40(1½")	22	19	0283.5	05.0	105	095	218	214	20	10.8	10.3
40(1½")X65(2½")	35	30	0706.8	07.5	125	120	297	278	20	20.1	19.2
50(2")X80(3")	45	38	1134.1	09.5	135	129	346	346	22	26.0	25.1
65(2½")X100(4")	58	49	1885.7	12.5	155	140	404	404	24	44.4	43.1
80(3")X125(5")	71	61	2922.5	15.5	175	160	487	487	24	63.4	61.7

## ■ Dimensional drawing

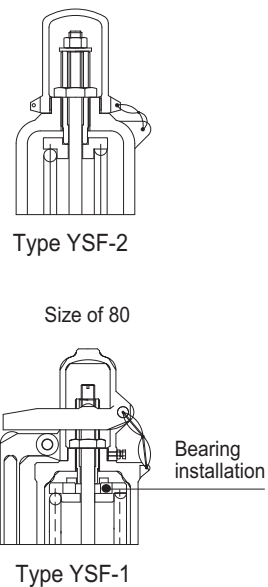
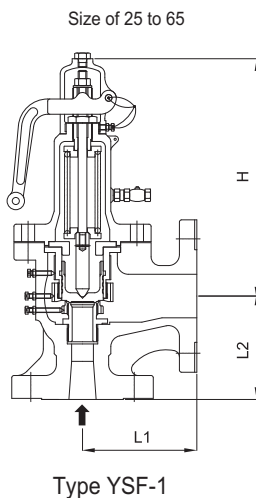

# Type YSF-3, 4 Safety Valve (Full Bore Type) Steam Boiler Pressure Vessel



Type YSF-3



Type YSF-4

## ■ Features

- Simple structure and outstanding performance.
- Superb performance, followed by strict quality control procedure.
- High impact resistance and good abrasion resistance : The disc and seat are stainless steel welded with satellite.
- Test lever attached : Periodical performance inspections can be conducted.
- Approval from the Korea Occupational Safety and Health Agency (KOSHA).

## ■ Specifications

Type		YSF-3(Close Bonnet)	YSF-4
Test lever		Yes	Optional
Applicable fluid		Steam, air	Liquid
Set pressure range		1~10kgf/cm <sup>2</sup> g, 10~20kgf/cm <sup>2</sup> g, 20~30kgf/cm <sup>2</sup> g	
Fluid temperature		220° C below	220° C below
End connection	Inlet	KS B 6216 10, 20, 30K RF FLANGE	
	Outlet	KS B 1511 10K FF FLANGE	
Material	Body	SCPH2	
	Disc, seat	STS (Stellite welding)	
Hydraulic test pressure		1.5 times of applicable flange rating	

▶ The JIS and ANSI flanges are available by made-to-orders.

## ■ Dimensions

(mm)

Size Inlet X Outlet	Seat diameter Ds	Throat diameter dt	Throat area a(mm <sup>2</sup> )	Lift ℓ	Face to Face		Height(h)		Weight(kg)	
					L1	L2	YSF-3	YSF-4	YSF-3	YSF-4
25(1")X40(1½")	22	19	283.5	5.0	115	100	249	264	13	12.4
40(1½")X65(2½")	35	30	706.8	7.5	130	125	340	316	25	14
50(2")X80(3")	45	38	1134.1	9.5	141	135	380	380	35.6	34.4
65(2½")X100(4")	58	49	1885.7	12.5	161	160	480	480	57	55.8
80(3")X125(5")	71	61	2922.5	15.5	179	180	535	535	79	77.2
100(4")X150(6")	88	76	4536.5	19.0	209	205	668	668	132	129
125(5")X200(8")	111	95	7088.2	24.0	232	240	846	828	273	269.5
150(6")X200(8")	134	115	10386.9	29.0	262	250	935	916	325	320
200(8")X250(10")	176	152	18145.8	38.0	355	300	1115	1135	645	633

## ■ Dimensional drawing

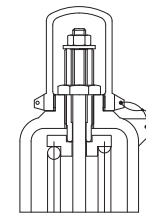
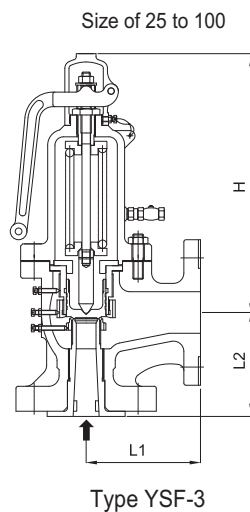

Type YSF-4

Size of 125 to 200

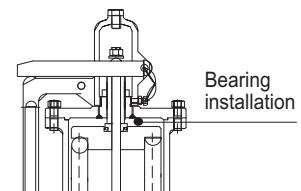

Type YSF-3

# Type YSF-5, 6 Safety Valve (Full Bore Type) Steam Boiler Pressure Vessel



Type YSF-5



Type YSF-6

## ■ Features

- Simple structure and outstanding performance.
- Superb performance, followed by strict quality control procedure.
- High impact resistance and good abrasion resistance : The disc and seat are stainless steel welded with satellite.
- Test lever attached : Periodical performance inspections can be conducted.
- Approval from the Korea Occupational Safety and Health Agency (KOSHA).

## ■ Specifications

Type	YSF-5	YSF-6
Test lever	Yes	Optional
Applicable fluid	Steam, air	Liquid
Set pressure range	1~10kgf/cm <sup>2</sup> g	
Fluid temperature	220° C below	
End connection	KS PT SCREW	
Materials	GC200 : Cast iron, Disc, seat: STS (Stellite welding)	
Hydraulic test pressure	15kgf/cm <sup>2</sup> g	

▶ The JIS and ANSI flanges are available by made-to-orders.

## ■ Dimensions

(mm)

Size Inlet X Outlet	Seat diameter Ds	Throat diameter dt	Throat area a(mm <sup>2</sup> )	Lift q	Face to Face		Height(h)		Connection size		Weight(kg)	
					L1	L2	YSF-5	YSF-6	IN	OUT	YSF-5	YSF-6
20(3/4")X25(1")	18	15	176.5	3.8	50	74	182	180	1"	1"	33	5.0
25(1")X32(1 1/4")	22	19	283.3	5.0	60	85	215	212	1 1/4"	1 1/4"	5.2	9.2
40(1 1/2")X50(2")	35	30	706.5	7.5	80	100	295	293	2"	2"	9.6	16.0
50(2")X65(2 1/2")	45	38	1133.5	9.5	90	115	335	332	2 1/2"	2 1/2"	16.0	3.2

## ■ For reference

In order to install the type YSF-5, 6 as a flange, a coupling flange is required by made-to-order.

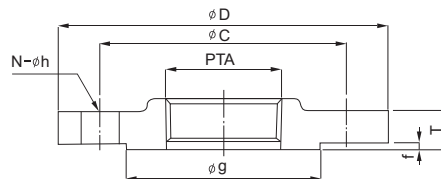

## » Dimensions (KS B 6216 10K RF FLANGE)

(mm)

Category Size	PTA	ø D	ø C	ø g	N-ø h	f	T
20(3/4")	1"	125	90	67	4-19	1	18
25(1")	1 1/4"	135	100	76	4-19	2	20
40(1 1/2")	2"	155	120	96	8-19	2	20
50(2")	2 1/2"	175	140	116	8-19	2	22

## ■ Dimensional drawing

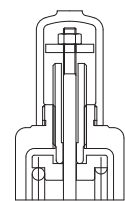
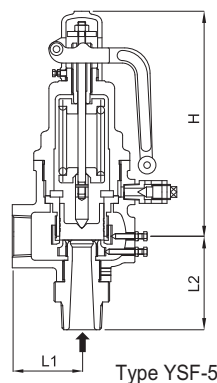

# Type YSF-3 Safety Valve (Open Bonnet Type, Full Bore Type) Steam Boiler



## ■ Features

- No instability in high temperatures : The maximum operating temperature of 450°C so that YSF-3 can be used without any changes in spring characteristics commonly occur in high temperatures.
- High impact resistance and good abrasion resistance : The disc and seat are stainless steel welded with satellite.
- Simple structure reduces maintenance costs & offers outstanding performance.
- High-strength stainless steel inner core components.
- Test lever attached : Periodical performance inspections can be conducted.
- Approval from the Korea Occupational Safety and Health Agency (KOSHA).

## ■ Specifications

Type		YSF-3 (Open Bonnet)
Test lever		Yes
Applicable fluid		Steam
Set pressure range		1~30kg/cm <sup>2</sup> g
Fluid temperature		350° C
End connection	Inlet	KS B 6216 10, 20, 30K RF FLANGE
	Outlet	KS B 1511 10K FF FLANGE
Materials	Body	SCPH2
	Disc, seat	STS (Stellite welding)
Hydraulic test pressure		1.5 times of applicable flange rating

▶ The JIS and ANSI flanges are available by made-to-orders.

## ■ Dimensions

Size Inlet×Outlet	Seat diameter	Throat diameter	Throat area	Lift	Face to Face		Height(h)	Weight(kg)
					L1	L2		
25(1")X40(1½")	22	19	283.5	5.0	115	100	320	15.2
40(1½")X65(2½")	35	30	706.8	7.5	130	125	425	28.6
50(2")X80(3")	45	38	1134.1	9.5	141	135	465	42.7
65(2½")X100(4")	58	49	1885.7	12.5	161	160	560	64
80(3")X125(5")	71	61	2922.5	15.5	179	180	630	89
100(4")X150(6")	88	76	4536.5	19.0	209	205	795	143
125(5")X200(8")	111	95	7088.2	24.0	232	240	1010	290
150(6")X200(8")	134	115	10386.9	29.0	262	250	1110	342
200(8")X250(10")	176	152	18145.8	38.0	355	300	1415	684

## ■ Dimensional drawing

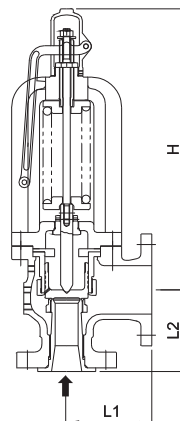



# Type YSL-1, 2 Safety Valve (Low Lift Type)

Boiler

Heat Exchanger

Secondary Side of Pressure Reducing Valve

2

The type YSL can be commonly used for various types of fluid (steam, vapor, liquid). It has a simple structure and is made of materials with a superb level of corrosion resistance. It is a safety valve that can be used for various purposes, such as a pressure vessel, safety device for various instruments and equipment, hot water boiler, water (including hot water) supplying equipment, cooling and heating facility, and safety device of pressure reducing valves.



Type YSL-1



Type YSL-2

## ■ Features

- Simple structure and outstanding performance.
- Disc and seat are free from leakage or transformation issues, thanks to a precision machining process.
- Test lever attached : Periodical performance inspections can be conducted.
- Approval from the Korea Occupational Safety and Health Agency (KOSHA).

## ■ Specifications

Type	YSL-1	YSL-2
Test lever	Yes	No
Applicable fluid	Steam, air	water
Set pressure range	0.35~10kgf/cm <sup>2</sup> g	
Fluid temperature	220° C below	
End connection	KS PT SCREW	
Materials	Body	GC200
	Disc, seat	STS
Hydraulic test pressure	15 kgf/cm <sup>2</sup> g	

## ■ Dimensions

(mm)

Size	Seat diameter	Lift	Effective area (mm)		Face to Face		Height(h)		Connection size		Weight(kg)	
	D		φ	πD <sup>2</sup> / 4	πD <sup>2</sup> /4	L1	L2	YSL-1	YSL-2	IN	OUT	YSL-1
15(1/2")X15(1/2")	15	0.4	18.8	176.6	40	41	127	112	1/2"	1/2"	1.1	1
20(3/4")X20(3/4")	20	0.5	31.4	314	50	50	137	122	3/4"	3/4"	1.8	1.7
25(1")X25(1")	25	0.7	54.9	490.8	55	60	162	148	1"	1"	3	2.9
40(1 1/2")X40(1 1/2")	40	1.0	125.6	1256.6	70	75	230	216	1 1/2"	1 1/2"	6.4	6.1
50(2")X50(2")	50	1.3	204.1	1963.5	80	80	245	245	2"	2"	9.3	9

## ■ Dimensional drawing

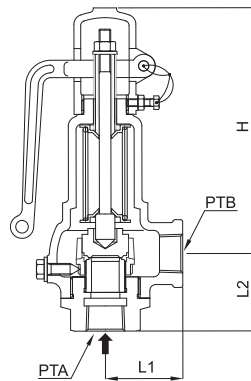

Type YSL-1

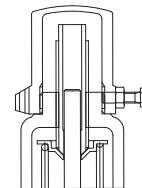

Type YSL-2

# Type YRV-1, 2 Relief Valve (for Pump Relief) For Pump Only



Type YRV-1



Type YRV-2

### ■ Dimensional drawing

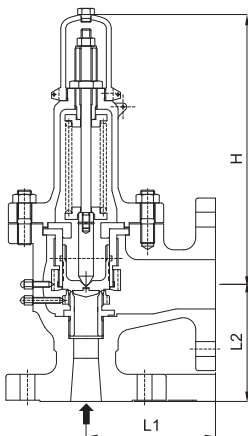

Type YRV-1

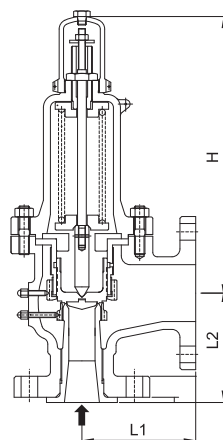

Type YRV-2

### ■ Features

- Specifically developed for pump use : Safe operation even in case of continuous relief.
- NOTE : Possibility of hunching or a water hammer if a safety valve is used as a relief valve of a pump.

### ■ Specifications

Type		YRV-1	YRV-2
Size		25A~80A	
Applicable fluid		Water	
Set pressure range		1.0~10kgf/cm <sup>2</sup> g	1.0~30kgf/cm <sup>2</sup> g
Fluid temperature		Max. 220° C	
End connection	Inlet	KS B 6216 10K RF FLANGE	KS B 6216 10, 20, 30K RF FLANGE
	Outlet	KS B 1511 10K RF FLANGE	
Materials	Body	GC200	SCPH2
	Disc, seat	STS	
Hydraulic test pressure		1.5 times of applicable flange rating	

▶ The JIS and ANSI flanges are available by made-to-orders.

### ■ Dimensions

Size Inlet x Outlet	Seat diameter Ds	Throat diameter dt	Throat area a(mm <sup>2</sup> )	Lift g	Face to Face (L)		Height(h)		Weight(kg)	
					YRV-1	YRV-2	YRV-1	YRV-2	YRV-1	YRV-2
25(1")X40(1½")	22	19	283.5	5.0	105	115	214	264	10.3	12.4
40(1½")X65(2½")	35	30	706.8	7.5	125	130	278	316	19.2	24
50(2")X80(3")	45	38	1134.1	9.5	135	141	346	380	25.1	34.3
65(2½")X100(4")	58	49	1885.7	12.5	155	161	404	480	43.1	55.8
80(3")X125(5")	71	61	2922.5	15.5	175	179	487	535	61.7	77.2

▶ Valves with a size of 100A or larger are available by made-to-orders.

### ■ Application Diagram (Example)

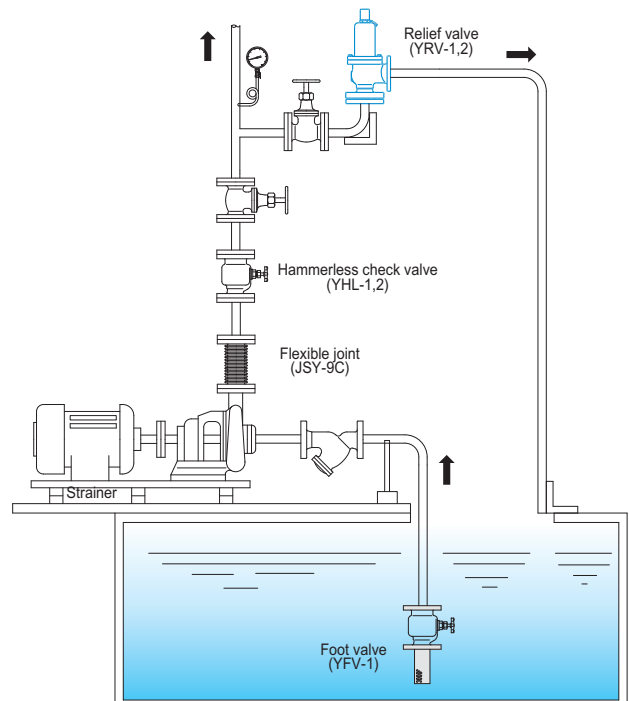

# Data / KS B 6216 Regulations on Safety Valves for Steam

## 2

### ■ Terminologies related to safety valves

Terminology	Definition
<b>Safety valve</b>	This valve automatically begins operation when the pressure on the inlet side reaches a pre-determined level. If the pressure decreases, this valve returns it to normal status. It has the ability to discharge fluid (steam or gas) based on the rated relieving capacity.
<b>Set pressure</b>	In the case of safety valves that require an opening pressure, this refers to the opening pressure that was determined in the design. In the case of safety valves that require a start-to-discharge pressure, this refers to the start-to-discharge pressure that was determined in the design. It is the pressure indicated on the product label.
<b>Start-to-discharge pressure</b>	This refers to the pressure when the safety valve begins to discharge. It is the pressure on the inlet side when an extremely small amount of fluid (steam or gas) discharge is detected on the outlet side.
<b>Opening pressure</b>	This refers to the inlet-side pressure when fluid is discharged as a result of operation of a safety valve. It is a pressure when the lift level becomes measurable, or a continuous discharge can be recognized.
<b>Flow rating pressure</b>	This pressure determines the rated relieving capacity regulated in the appendix.
<b>Closing pressure</b>	This is the inlet-side pressure when the safety valve has closed, resulting from the pressure dropping from the opening pressure, and the flow of the fluid has practically come to a stop, leading to a lift level of 0.
<b>Blowdown</b>	In terms of safety valves that require an opening pressure, this refers to the difference between the opening pressure and closing pressure. In terms of safety valves that require a start-to-discharge pressure, this refers to the difference between the start-to-discharge pressure and closing pressure.
<b>Lift</b>	The axial direction movement amount of a valve stem or a disc, from the valve closing location to the valve opening location during a safety valve discharge.
<b>Rated relieving capacity</b>	This refers to a discharge capacity that is guaranteed for each safety valve. It is determined according to regulations stipulated in 3.2.4(2) of KS B 6352 (discharge coefficient measurement method for safety valves) or in the appendix.
<b>Certified coefficient of discharge</b>	This is a coefficient applied to the rated relieving capacity. It is determined based on regulations set forth in 3.2.4(1) of KS B 6352 or a method that is recognized as being equivalent to the regulations.
<b>Hole diameter of disc seat</b>	This is the inner diameter of the interface of a disc and a disc seat (Refer to the attached chart in the appendix).
<b>Effective discharge area</b>	This refers to the area of the part that determines the flow passing through a safety valve. It is used for calculating the rated relieving capacity (Refer to the attached chart in the appendix).
<b>Throat diameter</b>	This refers to the inner diameter of the narrowest part of the nozzle extending from the fluid inlet to the disc seat surface.
<b>Back pressure</b>	This is the pressure on the outlet side of a safety valve. It has the following two kinds: (a) Pressure that is built on the outlet side of a safety valve as a result of exhaust-side resistance when the safety valve discharges. (b) Pressure that already exists on the exhaust side before the safety valve begins to discharge.

# Data / KS B 6216 Regulations on Safety Valves for Steam

## Types and performance

### 1. Types

Safety valves are categorized into the following types according to whether a valve has a flow-restricting fixture and sealing structure.

Type	Flow-restricting fixture	Standard flow velocity (m/s)
A	Lift type : The lift of the safety valve is 1/40 or larger and smaller than 1/4 of the disc seat hole diameter. The area of the fluid passage of the disc seat hole is the minimum when the disc is open.	Sealed
B		Open
C	Full bore type : The disc seat hole diameter is at least 1.15 times the throat diameter. The area of the fluid passage of the disc seat hole is at least 1.05 times the throat area when the disc is open. The area of the fluid passage within the pipeline and the inlet of the safety valve should be at least 1.7 times the throat area.	Sealed
D		Open

### 2. Opening pressure allowance

- The following shows the opening pressure allowance for a spring safety valve for steam.
- The permissible range for a spring safety valve for gas is from the set pressure to less than 1.1 times the set pressure.

Unit: kgf/cm<sup>2</sup>(MPa)

Set pressure	Allowance
Less than 5(0.5)	±0.14(0.14)
5(0.5) or higher	±(3% of set pressure)
23(2.3) or higher	±0.7(0.07)
Less than 70(7.0)	±(1% of set pressure)

► The opening pressure allowance of safety valves for steam, other than boilers, is ±3% (minimum value of ±0.14 kgf/cm<sup>2</sup>) of the set pressure.

### 3. Blowdown

- The blowdown of a spring safety valve for steam should be carried out as follows, based on the opening pressure.

Unit: kgf/cm<sup>2</sup>(MPa)

Opening pressure	Blowdown
4(0.4) or less	0.3(0.03) or less
Higher than 4(0.4)	7%(4%) or less of opening pressure

► Notes : It is possible to decide on the value in the parenthesis, according to an agreement between relevant parties. However, if the opening pressure of safety valves for steam that are used for once-through boilers, reheat pipes, etc. exceeds 3 kgf/cm<sup>2</sup>g, it can be 10% or less of the set pressure.

- The blowdown pressure of the spring safety valve for gas and spring safety valve for steam that is installed on surplus pipeline is as follows, based on the opening pressure or set pressure.

Unit: kgf/cm<sup>2</sup>(MPa)

Set pressure	Blowdown	
	Without using a soft seat on disc seat surface	Using a soft seat on disc seat surface
2(0.2) or less	Maximum 0.3(0.03)	Maximum 0.5(0.05)
Higher than 2(0.2)	Maximum 15% of set pressure	Maximum 25% of set pressure

► Notes : A soft seat has a disc seat surface treated with a synthetic resin.

# Data / KS B 6216 Regulations on Safety Valves for Steam

## 2

### ■ Calculation of discharge capacity

#### ● KS B 6216 standard on safety valves for steam and gas

##### A. For steam

$$W = 0.5145 \times A \times (P+1) \times K \times C \times 0.9$$

Here,

W : Rated relieving capacity (kg/h)

A : Minimum steam passage area (mm<sup>2</sup>)

In case of low lift, high lift, and warm lift types,  $A = \pi DL$

In case of full bore types,  $A = \frac{\pi}{4} d^2$

D : Valve seat diameter (mm)

L : Valve lift (mm)

Lift type  $L = \frac{D}{40} \sim \frac{D}{15}$

D : Throat diameter (mm)

P : Flow rating pressure (kgf/cm<sup>2</sup>g)

If not specifically stated otherwise, this is 1.03 times the opening pressure if the maximum pressure used exceeds 1 kgf/cm<sup>2</sup>g.

A total of 0.2 kgf/cm<sup>2</sup>g is added to the opening pressure if the maximum pressure used is 1 kgf/cm<sup>2</sup>g or less. If specifically stated otherwise, the corresponding value should be used.

K : Certified coefficient of discharge (Refer to Chart 1)

C : Coefficient based on steam characteristics (Refer to Chart 2)

If the certified coefficient of discharge of a safety valve is not measured, the rated relieving capacity can be calculated by using the K' value determined based on Chart 1, instead of the K value in the calculation formula above; provided that K' equals 0.864 in case of full bore type safety valves.

Chart 1. Certified coefficient of discharge

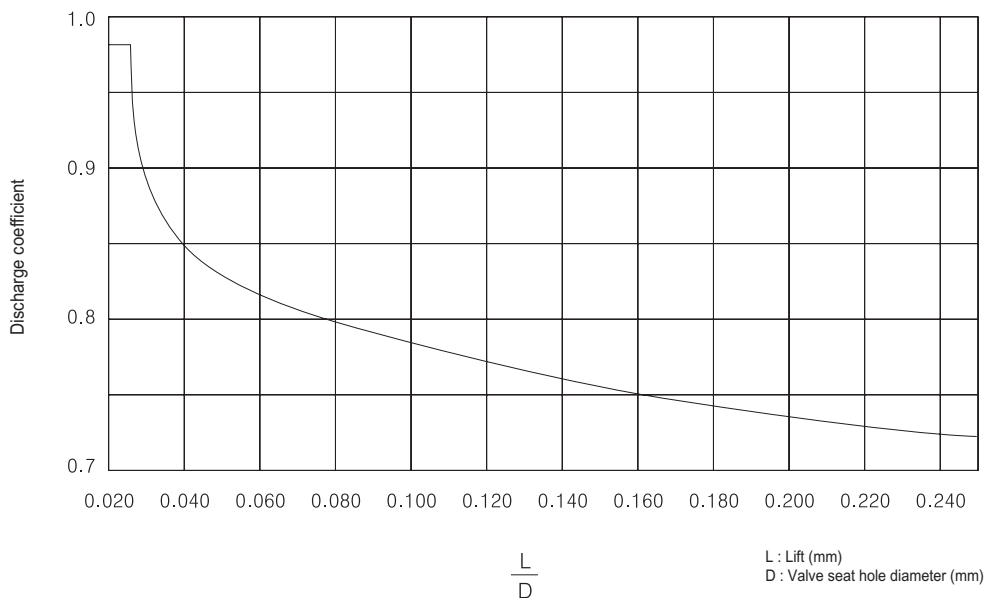

# Data / KS B 6216 Regulations on Safety Valves for Steam

Temperature Absolute pressure kg/cm <sup>2</sup> (MPa)	Saturated temperature	200	220	240	260	280	300	320	340	360	380	400	420	440	460	480	500	520	540	560	580	600	620	640	660	680	700
		5( 0.5)	1.005	0.996	0.972	0.951	0.931	0.913	0.896	0.879	0.864	0.849	0.835	0.822													
10( 1.0)	0.987	0.981	0.983	0.960	0.938	0.919	0.901	0.884	0.868	0.853	0.838	0.825															
15( 1.5)	0.977	0.976	0.970	0.972	0.947	0.925	0.906	0.888	0.872	0.856	0.841	0.828															
20( 2.0)	0.972	0.967	0.964	0.955	0.932	0.912	0.893	0.876	0.860	0.845	0.830	0.817	0.804	0.792	0.780	0.780	0.780	0.780	0.780	0.780	0.780	0.780	0.780	0.780	0.780	0.780	0.780
25( 2.5)	0.969	0.965	0.961	0.955	0.937	0.918	0.898	0.880	0.863	0.848	0.833	0.820	0.807	0.795	0.782	0.782	0.782	0.782	0.782	0.782	0.782	0.782	0.782	0.782	0.782	0.782	0.782
30( 3.0)	0.967	0.965	0.962	0.957	0.949	0.924	0.903	0.885	0.867	0.851	0.836	0.822	0.809	0.795	0.782	0.782	0.782	0.782	0.782	0.782	0.782	0.782	0.782	0.782	0.782	0.782	0.782
40( 4.0)	0.966	0.966	0.958	0.955	0.954	0.934	0.915	0.894	0.875	0.857	0.841	0.826	0.813	0.799	0.787	0.787	0.787	0.787	0.787	0.787	0.787	0.787	0.787	0.787	0.787	0.787	0.787
50( 5.0)	0.966	0.966	0.962	0.955	0.953	0.934	0.915	0.894	0.875	0.857	0.841	0.826	0.813	0.799	0.787	0.787	0.787	0.787	0.787	0.787	0.787	0.787	0.787	0.787	0.787	0.787	0.787
60( 6.0)	0.968	0.968	0.962	0.955	0.953	0.934	0.915	0.894	0.875	0.857	0.841	0.826	0.813	0.799	0.787	0.787	0.787	0.787	0.787	0.787	0.787	0.787	0.787	0.787	0.787	0.787	0.787
70( 7.0)	0.971	0.971	0.967	0.962	0.958	0.954	0.937	0.918	0.898	0.880	0.863	0.848	0.833	0.820	0.807	0.807	0.807	0.807	0.807	0.807	0.807	0.807	0.807	0.807	0.807	0.807	0.807
80( 8.0)	0.975	0.975	0.967	0.962	0.958	0.954	0.937	0.918	0.898	0.880	0.863	0.848	0.833	0.820	0.807	0.807	0.807	0.807	0.807	0.807	0.807	0.807	0.807	0.807	0.807	0.807	0.807
90( 9.0)	0.980	0.980	0.967	0.962	0.958	0.954	0.937	0.918	0.898	0.880	0.863	0.848	0.833	0.820	0.807	0.807	0.807	0.807	0.807	0.807	0.807	0.807	0.807	0.807	0.807	0.807	0.807
100(10.0)	0.986	0.986	0.971	0.962	0.958	0.954	0.937	0.918	0.898	0.880	0.863	0.848	0.833	0.820	0.807	0.807	0.807	0.807	0.807	0.807	0.807	0.807	0.807	0.807	0.807	0.807	0.807
120(12.0)	0.999	0.999	0.971	0.962	0.958	0.954	0.937	0.918	0.898	0.880	0.863	0.848	0.833	0.820	0.807	0.807	0.807	0.807	0.807	0.807	0.807	0.807	0.807	0.807	0.807	0.807	0.807
140(14.0)	1.016	1.016	0.971	0.962	0.958	0.954	0.937	0.918	0.898	0.880	0.863	0.848	0.833	0.820	0.807	0.807	0.807	0.807	0.807	0.807	0.807	0.807	0.807	0.807	0.807	0.807	0.807
160(16.0)	1.036	1.036	0.971	0.962	0.958	0.954	0.937	0.918	0.898	0.880	0.863	0.848	0.833	0.820	0.807	0.807	0.807	0.807	0.807	0.807	0.807	0.807	0.807	0.807	0.807	0.807	0.807
180(18.0)	1.063	1.063	0.971	0.962	0.958	0.954	0.937	0.918	0.898	0.880	0.863	0.848	0.833	0.820	0.807	0.807	0.807	0.807	0.807	0.807	0.807	0.807	0.807	0.807	0.807	0.807	0.807
200(20.0)	1.094	1.094	0.971	0.962	0.958	0.954	0.937	0.918	0.898	0.880	0.863	0.848	0.833	0.820	0.807	0.807	0.807	0.807	0.807	0.807	0.807	0.807	0.807	0.807	0.807	0.807	0.807
220(22.0)	1.129	1.129	0.971	0.962	0.958	0.954	0.937	0.918	0.898	0.880	0.863	0.848	0.833	0.820	0.807	0.807	0.807	0.807	0.807	0.807	0.807	0.807	0.807	0.807	0.807	0.807	0.807
240(24.0)			0.971	0.962	0.958	0.954	0.937	0.918	0.898	0.880	0.863	0.848	0.833	0.820	0.807	0.807	0.807	0.807	0.807	0.807	0.807	0.807	0.807	0.807	0.807	0.807	0.807
260(26.0)			0.971	0.962	0.958	0.954	0.937	0.918	0.898	0.880	0.863	0.848	0.833	0.820	0.807	0.807	0.807	0.807	0.807	0.807	0.807	0.807	0.807	0.807	0.807	0.807	0.807
280(28.0)			0.971	0.962	0.958	0.954	0.937	0.918	0.898	0.880	0.863	0.848	0.833	0.820	0.807	0.807	0.807	0.807	0.807	0.807	0.807	0.807	0.807	0.807	0.807	0.807	0.807
300(30.0)			0.971	0.962	0.958	0.954	0.937	0.918	0.898	0.880	0.863	0.848	0.833	0.820	0.807	0.807	0.807	0.807	0.807	0.807	0.807	0.807	0.807	0.807	0.807	0.807	0.807
320(32.0)			0.971	0.962	0.958	0.954	0.937	0.918	0.898	0.880	0.863	0.848	0.833	0.820	0.807	0.807	0.807	0.807	0.807	0.807	0.807	0.807	0.807	0.807	0.807	0.807	0.807
340(34.0)			0.971	0.962	0.958	0.954	0.937	0.918	0.898	0.880	0.863	0.848	0.833	0.820	0.807	0.807	0.807	0.807	0.807	0.807	0.807	0.807	0.807	0.807	0.807	0.807	0.807
360(36.0)			0.971	0.962	0.958	0.954	0.937	0.918	0.898	0.880	0.863	0.848	0.833	0.820	0.807	0.807	0.807	0.807	0.807	0.807	0.807	0.807	0.807	0.807	0.807	0.807	0.807
380(38.0)			0.971	0.962	0.958	0.954	0.937	0.918	0.898	0.880	0.863	0.848	0.833	0.820	0.807	0.807	0.807	0.807	0.807	0.807	0.807	0.807	0.807	0.807	0.807	0.807	0.807
400(40.0)			0.971	0.962	0.958	0.954	0.937	0.918	0.898	0.880	0.863	0.848	0.833	0.820	0.807	0.807	0.807	0.807	0.807	0.807	0.807	0.807	0.807	0.807	0.807	0.807	0.807
420(42.0)			0.971	0.962	0.958	0.954	0.937	0.918	0.898	0.880	0.863	0.848	0.833	0.820	0.807	0.807	0.807	0.807	0.807	0.807	0.807	0.807	0.807	0.807	0.807	0.807	0.807
440(44.0)			0.971	0.962	0.958	0.954	0.937	0.918	0.898	0.880	0.863	0.848	0.833	0.820	0.807	0.807	0.807	0.807	0.807	0.807	0.807	0.807	0.807	0.807	0.807	0.807	0.807
460(46.0)			0.971	0.962	0.958	0.954	0.937	0.918	0.898	0.880	0.863	0.848	0.833	0.820	0.807	0.807	0.807	0.807	0.807	0.807	0.807	0.807	0.807	0.807	0.807	0.807	0.807

▶ Remarks - The intermediate value of pressure and temperature in this chart is calculated according to the rule of three.

# Data / KS B 6216 Regulations on Safety Valves for Steam

## 2

### ■ Calculation of discharge capacity

#### B. For Gas

① In case  $P_2 / P_1$  value is below threshold value

$$W = C \times K \times A \times P_1 \times \sqrt{\frac{M}{Z \times T}} \times 0.9$$

Here,

W : Rated relieving capacity (kg/h)

C : In case coefficient following the isentropic exponent of gas (see graph 3), it is set as C=234.

A : Effective discharge area (mm<sup>2</sup>)

Lift type A =  $\pi DL$

Full bore type A =  $\frac{\pi}{4} d^2$

D : Valve seat diameter (mm)

L : Valve lift (mm)

Lift type L =  $\frac{D}{40} \sim \frac{D}{15}$

D : Throat diameter (mm)

$P_1$  : It is the absolute pressure(kgf/cm<sup>2</sup>) of the flow rating pressure.

If not specifically stated otherwise, this is 1.1 times the set pressure.

$P_2$  : Absolute pressure of back pressure (kgf/cm<sup>2</sup>)

M : Molecular weight of gas (Refer to Chart 4)

Z : Compression coefficient

T : Absolute temperature of gas with regard to flow rating pressure

② In case the value of  $P_1 / P_2$  exceeds threshold value

$$W = C \times K \times A \times P_1 \sqrt{\frac{k}{k-1} \left\{ \left( \frac{P_2}{P_1} \right)^{2/k} - \left( \frac{P_2}{P_1} \right)^{k+1} \right\}} \sqrt{\frac{M}{Z \times T}} \times 0.9$$

Here,

K, W, A,  $P_1$ ,  $P_2$ , M, Z, T follows the regulation of 1.

$\kappa$  equals 1,000.

$\kappa$  equals the value of isentropic exponent in  $P_1$ .

If the value in  $P_1$  is unclear, it takes the value of standard conditions, and if this value is also unclear,  $\kappa$  equals 1,001.

In case the certified coefficient of discharge of the safety valve is not measured, rated relieving capacity(kg/h) can be calculated using K' value obtained from Chart 1 instead of k value from the calculation formula above. Provided that K' equals 0.864 in case of full bore type safety valves.

Chart 1. C' value

k	C'	k	C'	k	C'	k	C'
1.00	234	1.20	251	1.40	265	1.60	277
1.02	237	1.22	252	1.42	266	1.62	278
1.04	238	1.24	254	1.44	267	1.64	280
1.06	240	1.26	255	1.46	268	1.66	281
1.08	242	1.28	257	1.48	270	1.68	282
1.10	244	1.30	258	1.50	271	1.70	283
1.12	245	1.32	260	1.52	272	1.80	289
1.14	246	1.34	261	1.54	274	1.90	293
1.16	248	1.36	263	1.56	275	2.00	298
1.18	250	1.38	264	1.58	276	2.20	307

# Data / Physical Properties

**■ [Chart 4] Physical properties of air and gas**

Type of fluid	Molecular formula	Molecular weight	Adiabatic index	Critical temperature	Critical pressure	Liquid	
						Specific gravity	Temperature
ACETYLEN	C <sub>2</sub> H <sub>2</sub>	26.04	1.26	308.7	63.7	-	-
AIR	NH <sub>3</sub>	28.96	1.40	132.5	38.4	-	-
AMMONIA	Ar	17.03	1.31	405.6	116.9	0.817	-79
ARGON	C <sub>6</sub> H <sub>6</sub>	39.95	1.67	150.8	50.4	1.650	-233
BENZENE	iso-C <sub>4</sub> H <sub>10</sub>	78.12	1.12	562.8	50.6	0.879	20
ISO-BUTANE	n-C <sub>4</sub> H <sub>10</sub>	58.13	1.10	408.2	37.7	0.557	20
N-BUTANE	CS <sub>2</sub>	58.13	1.09	425.5	38.2	0.579	20
CARBON DISULFIDE	CO <sub>2</sub>	76.14	1.21	549.2	78.0	1.263	20
CARBON ACID GAS	CO	44.00	1.29	304.2	77.8	0.101	-37
CARBON MONOXIDE	Cl <sub>2</sub>	28.01	1.40	133.0	36.9	0.814	-194
CHLORINE	C <sub>6</sub> H <sub>12</sub>	70.91	1.36	417.2	79.8	1.560	-34
CYCLOHEXANE	n-C <sub>10</sub> H <sub>22</sub>	84.16	1.09	481.6	41.4	0.779	20
N-DECANE	C <sub>2</sub> H <sub>6</sub>	142.29	1.03	618.4	21.7	0.734	15.6
ETHANE	C <sub>2</sub> H <sub>5</sub> OH	30.07	1.19	305.4	49.9	0.546	-88
ETHYL ALCOHOL	C <sub>2</sub> H <sub>4</sub>	46.07	-	516.2	65.0	0.789	20
ETHYLENE	n-CH <sub>3</sub> (CH <sub>2</sub> ) <sub>3</sub> CH <sub>3</sub>	28.05	1.24	282.7	51.9	0.566	-102
HELIUM	n-C <sub>7</sub> H <sub>16</sub>	4.00	1.66	5.3	5.4	-	-
N-HEPTANE	n-C <sub>8</sub> H <sub>14</sub>	100.21	1.05	540.2	27.8	-	-
N-HEXANE	HCl	86.18	1.06	507.7	30.9	0.659	20
HYDROCHLORIC ACID	H <sub>2</sub>	36.46	1.41	324.7	86.0	-	-
HYDROGEN	H <sub>2</sub> S	2.02	1.41	33.2	13.5	0.079	-253
SULFURETED HYDROGEN	CH <sub>4</sub>	34.08	1.321	373.6	93.4	-	-
METHANE	CH <sub>3</sub> OH	16.04	1.31	190.9	48.0	0.415	-164
METHYL ALCOHOL	CH <sub>3</sub> Cl	32.04	1.20	512.6	81.8	0.792	20
METHYL CHLORIDE	N <sub>2</sub>	50.49	1.20	416.3	68.8	0.952	0
NITROGEN	N <sub>2</sub> O	28.01	1.40	126.3	35.4	1.026	-252
NITROUS OXIDE	n-CH <sub>3</sub> (CH <sub>2</sub> ) <sub>7</sub> CH <sub>3</sub>	44.01	1.30	309.3	75.4	1.226	-89
N-NONAN	O <sub>2</sub>	128.26	1.04	594.7	23.5	0.718	20
OXYGEN	n-CH <sub>3</sub> (CH <sub>2</sub> ) <sub>3</sub> CH <sub>3</sub>	32.00	1.40	154.7	52.5	1.426	-252
N-PENTANE	n-CH <sub>3</sub> CH <sub>2</sub> CH <sub>3</sub>	72.15	1.07	470.1	34.2	0.631	15.6
NPROPANE	H <sub>2</sub> O	44.11	1.13	370.0	43.5	0.585	-45
STEAM	SO <sub>2</sub>	18.02	1.33	647.1	225.8	1.000	4
SULPHUR DIOXIDE	C <sub>6</sub> H <sub>5</sub> CH <sub>3</sub>	64.06	1.29	593.6	43.1	0.906	20
TOLUENE	CH <sub>3</sub> CHCH <sub>2</sub>	92.15	1.09	593.6	43.1	0.866	20
PROPYLENE	C <sub>6</sub> H <sub>18</sub>	42.08	1.15	365.1	46.9	0.609	-47
OCTANE		114.00	1.05	-	-	-	-



# Data / Discharge Capacity Table of Safety Valves (KSB6216) for Steam

2

## ■ Discharge capacity table

$$W = 0.5145 \times K \times A \times P \times Ksh \times 0.9$$

### ● Full bore type

Type	P size dt	(kg/h)																													
		1	2	3	4	5	6	7	8	9	10	11	12	13	14	15	16	17	18	19	20	21	22	23	24	25	26	27	28	29	30
20X	25	146	218	291	364	437	509	582	655	728	800	873	946	1,018	1,091	1,164	1,237	1,309	1,382	1,455	1,528	1,600	1,673	1,746	1,819	1,891	1,964	2,037	2,109	2,182	2,255
	40	234	351	468	584	701	818	935	1,052	1,169	1,285	1,402	1,519	1,636	1,753	1,870	1,986	2,103	2,220	2,337	2,454	2,570	2,687	2,804	2,921	3,038	3,155	3,271	3,388	3,505	3,622
	65	583	875	1,166	1,457	1,748	2,040	2,331	2,622	2,913	3,205	3,496	3,787	4,078	4,370	4,661	4,952	5,243	5,535	5,826	6,117	6,408	6,700	6,991	7,282	7,574	7,865	8,156	8,447	8,739	9,030
50X	80	936	1,403	1,871	2,338	2,805	3,274	3,740	4,207	4,675	5,142	5,609	6,077	6,544	7,011	7,479	7,946	8,413	8,881	9,348	9,815	10,283	10,750	11,217	11,685	12,152	12,619	13,087	13,554	14,021	14,489
	100	1,556	2,333	3,110	3,888	4,665	5,442	6,219	6,996	7,773	8,550	9,327	10,104	10,881	11,658	12,435	13,212	13,989	14,766	15,543	16,320	17,097	17,875	18,652	19,429	20,206	20,983	21,760	22,537	23,314	24,091
	125	2,412	3,616	4,821	6,025	7,229	8,434	9,638	10,842	12,046	13,251	14,455	15,659	16,864	18,068	19,272	20,477	21,681	22,885	24,089	25,294	26,498	27,702	28,907	30,111	31,315	32,520	33,724	34,928	36,132	37,337
100X	150	3,744	5,614	7,483	9,352	11,222	13,091	14,961	16,830	18,699	20,569	22,438	24,308	26,177	28,046	29,916	31,785	33,654	35,524	37,393	39,263	41,132	43,001	44,871	46,740	48,610	50,479	52,348	54,218	56,087	57,957
	200	5,850	8,711	11,699	14,613	17,534	20,455	23,376	26,292	29,217	32,138	35,059	37,980	40,901	43,822	46,743	49,664	52,584	55,505	58,426	61,347	64,268	67,189	70,110	73,031	75,952	78,872	81,793	84,714	87,635	90,556
	250	8,573	12,853	17,133	21,414	25,694	29,974	34,254	38,534	42,815	47,095	51,375	55,655	59,935	64,216	68,496	72,776	77,056	81,336	85,617	89,897	94,177	98,457	102,737	107,018	111,298	115,578	119,858	124,138	128,419	132,699
200X	300	14,977	22,454	29,932	37,409	44,887	52,364	59,842	67,319	74,797	82,274	89,751	97,229	104,706	112,184	119,661	127,139	134,616	142,094	149,571	157,049	164,526	172,004	179,481	186,959	194,436	201,914	209,391	216,869	224,346	231,824
	400	34,292	51,412	68,533	85,654	102,775	119,896	137,017	154,137	171,258	188,379	205,500	222,621	239,741	256,862	273,983	292,104	308,225	325,346	342,466	359,587	376,708	393,829	410,950	428,071	445,191	462,312	479,433	496,554	513,675	530,796

$$W = \frac{1.03P+1}{22} AC \dots C=1$$

W : Discharge capacity  
 P : Opening pressure (kg/cm<sup>2</sup>)  
 A : Throat area (π DL)  
 L : Lift (mm)  
 D : Seat diameter

### ● Low lift type

Model	size	(kg/h)										
		0.5	1	2	3	4	5	6	7	8	9	10
YSL-1	15		15	23	31	39	46	54	62	69	77	85
	20	0.4395	26	38	51	64	77	90	103	116	129	142
	25	1.0956	45	67	90	112	135	158	180	203	226	248
	40	1.7579	102	154	206	257	309	361	413	464	516	568
	50	2.9229	166	250	334	418	502	586	670	754	839	923

# Data / Discharge Capacity Table of Safety Valves (KSB6216) for Steam

## ■ Discharge capacity table

$$W = 220A(P+1)\sqrt{\frac{M}{T}} \dots\dots M = 28.96 \quad T = 293$$

● Full bore type

Type	size	P																													
		1	2	3	4	5	6	7	8	9	10	11	12	13	14	15	16	17	18	19	20	21	22	23	24	25	26	27	28	29	30
YSF-1 YSF-3 YSF-5	20X25	295	447	599	751	903	1055	1207	1359	1511	1663	1815	1968	2120	2272	2424	2576	2728	2880	3032	3184	3336	3488	3640	3792	3944	4096	4248	4400	4553	4705
	25X40	473	717	961	1205	1449	1693	1937	2181	2425	2669	2913	3157	3401	3645	3889	4133	4377	4621	4864	5108	5352	5596	5840	6084	6328	6572	6816	7060	7304	7548
	40X65	1180	1788	2396	3005	3613	4221	4830	5438	6046	6655	7263	7871	8480	9088	9696	10305	10913	11521	12129	12738	13346	13954	14563	15171	15779	16388	16996	17604	18213	18821
	50X80	1892	2888	3884	4880	5796	6772	7748	8724	9700	10676	11652	12628	14580	14580	15556	16532	17508	18484	19460	20436	21412	22388	23364	24339	25315	26291	27267	28243	29219	30195
	65X100	3147	4769	6392	8015	9638	11260	12883	14506	16129	17751	19374	20997	24242	24242	25865	27488	29111	30733	32356	33979	35602	37224	38847	40470	42093	43715	45338	46961	48584	50206
80X125	4877	7392	9907	12422	14937	17452	19967	22484	24997	27512	30027	32541	37571	37571	40086	42601	45116	47631	50146	52661	55176	57691	60206	62721	65236	67751	70266	72781	75296	77811	
100X150	7570	11474	15378	19282	23186	27090	30994	34897	38801	42705	46609	50513	58321	58321	62225	66129	70033	73937	77840	81744	85648	89552	93456	97360	101264	105168	109072	112976	116880	120783	
125X200	11828	17928	24028	30127	36227	42327	48427	54527	60626	66726	72826	78926	91125	91125	97225	103325	109425	115524	121624	127724	133824	139924	146023	152123	158223	164323	170423	176522	182622	188722	
150X200	17333	26271	35210	44148	53087	62025	70964	79902	88841	97779	106718	115656	133533	133533	142472	151410	160349	169287	178226	187164	196103	205041	213980	222918	231857	240795	249734	258672	267611	276549	
200X250	30280	45895	61511	77126	92742	108357	123973	139588	155204	170819	186435	202050	233281	233281	248896	264512	280127	295743	311358	326974	342589	358205	373820	389436	405051	420667	436282	451898	467513	483128	
300X400	69330	105084	140838	176592	212346	248100	283854	319608	355362	391116	426871	462625	534133	534133	596687	605641	641395	677149	712903	748657	784411	820165	855919	891673	927427	963181	998935	1034689	1070443	1106197	

$$A = W/CKF\sqrt{\frac{M}{T}} \dots\dots C = 265, P_1 = P+1.03 \quad K = 0.87, M = 28.96, T = 293$$

● Low lift type

Type	size	P									
		1	2	3	4	5	6	7	8	9	10
YSL-1	15	31	48	64	80	96	112	128	145	161	177
	20	52	79	106	133	160	188	215	242	269	296
	25	92	139	186	233	281	328	375	422	470	517
	40	210	318	426	534	642	750	858	966	1074	1182
	50	341	516	692	867	1043	1219	1394	1570	1746	1921



# Data / Safety Valves

## ■ Cautionary measures

### ● Cautionary measures when handling safety valves

Safety valves cannot be used in good conditions unless the following cautionary measures are taken. This is because impacts can lead to changes in the precisely adjusted opening pressure.

- (1) Safety valves should be protected from external impact.
- (2) In order to prevent the entry of foreign substances into the inside of the valve, the cover plate should not be removed until the safety valve is installed.
- (3) When installing the valve, completely remove scales, sand, dregs, etc. and do not remove the cover plate.
- (4) If the opening pressure is different from the pressure gauge readings, check the pressure gauge first.
- (5) Install the valve vertically, and do not remove the attached seal.

### ● Cautionary measure during installation

Install the safety valve vertically, in an upright position, in a pressure pipeline or coupling device. Install it as closely as possible to ensure the smooth flow of fluid between the pipeline and valve.

### ● Outlet pipeline

- (1) A discharge pipeline should be installed, and at a safe place.
- (2) The discharge pipeline should be bigger than the size on the outlet side to lower the back pressure to the same level as the atmospheric pressure. If possible, it should not be bent and should be short.
- (3) The discharge pipeline should be fixed to a building or other structure so that it withstands vibration caused by outside atmospheric pressure changes or rapid flow of fluid during discharge.
- (4) An appropriate bellows type expansion pipe joint should be installed on the outlet side in cases where inappropriate results might occur from heat expansion of the discharge pipeline.

※ The length of the discharge pipes should be set as follows, based on the size of the valve.

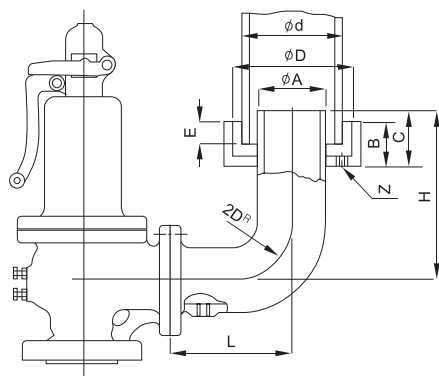

### › Dimensions

Size on outlet side	D	d	A	B	C	E	L	H	N
40	40	65	130	60	80	30	130	220	PT $\frac{3}{8}$ "
50	50	80	150	60	90	40	150	230	PT $\frac{1}{2}$ "
65	65	100	200	60	100	40	180	270	PT $\frac{1}{2}$ "
80	80	125	200	70	120	50	200	310	PT $\frac{1}{2}$ "
100	100	150	250	70	140	60	250	370	PT $\frac{3}{4}$ "
125	125	200	300	80	160	70	300	430	PT1"
150	150	200	300	80	180	80	350	500	PT1"
200	200	250	380	100	220	80	450	610	PT1"

(kg/h)

# Data / KS B 6216 Regulations on Full Bore Type Safety Valves

2

■ Table on standards for flanges on the inlet side of full bore type safety valves

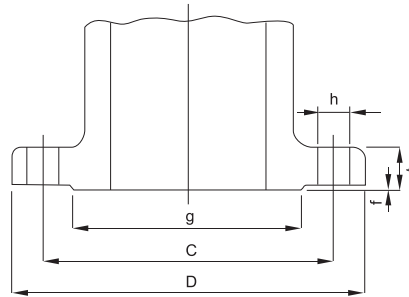

Nominal pressure of safety valve	Size	Flange				Bolt hole			Nominal size of bolt screw	
		D	t(Minimum)	f	g	c	Water	h		
New type	10K	20	125	18	1	67	920	4	19	M16
		25	135	20	2	76	100	4	19	M16
		32	140	20	2	81	105	4	19	M16
		40	155	20	2	96	120	8	19	M16
		50	175	22	2	116	140	8	19	M16
		65	200	24	2	132	160	8	23	M20
		80	210	24	2	145	170	8	23	M20
		(90)	225	26	2	160	185	8	23	M20
	100	270	26	2	195	225	8	25	M22	
	125	305	28	2	230	260	12	25	M22	
	150	350	30	2	275	305	12	25	M22	
	200	430	34	2	345	380	12	27	M24	
	20K	25	130	20	1	70	95	4	19	M16
		25	140	22	2	80	105	4	19	M16
		32	160	22	2	90	120	4	23	M20
		40	165	22	2	105	130	8	19	M16
50		200	26	2	130	160	8	23	M16	
65		210	28	2	140	170	8	23	M20	
80		230	30	2	150	185	8	25	M22	
(90)		240	32	2	160	195	8	25	M22	
100	275	36	2	195	230	8	25	M22		
125	325	38	2	235	275	12	27	M24		
150	370	42	2	280	320	12	27	M24		
200	450	48	2	345	390	12	33	M30 X 3		
Old type	10K	20	125	22	1	70	90.0	4	19	M16
		25	130	22	1	75	95	4	19	M16
		32	140	24	2	85	105	4	19	M16
		40	155	24	2	100	120	8	19	M16
		50	165	26	2	110	130	8	19	M16
		65	200	28	2	135	160	8	23	M20
		80	210	30	2	145	170	8	23	M20
		(90)	225	30	2	160	185	8	23	M20
	100	245	32	2	180	205	8	23	M20	
	(115)	270	32	2	195	225	8	25	M22	
	125	280	34	2	205	235	12	25	M22	
	150	325	36	2	250	280	12	25	M22	
	200	385	38	2	300	335	12	27	M24	
	20K	20	130	22	1	70	95	4	19	M16
		25	135	22	1	75	100	4	19	M16
		32	160	24	2	90	120	4	23	M20
40		165	24	2	105	130	8	19	M16	
50		185	26	2	115	145	8	23	M20	
65		210	30	2	140	170	8	23	M20	
80		230	32	2	150	185	8	25	M22	
(90)		240	34	2	160	195	8	25	M22	
100	265	36	2	185	220	8	25	M22		
(115)	275	38	2	195	230	8	25	M22		
125	290	38	2	210	245	12	25	M22		
150	350	42	2	260	300	12	27	M24		
200	410	46	2	310	350	12	27	M24		

►Notes: It is recommended that the size in the parenthesis not be used.

# Steam Trap

# 3

## Steam Trap



Steam traps automatically discharge condensate only, without steam leakages, thereby minimizing thermal loss and preventing condensate disturbance, such as a water hammer.

### Steam trap

Type	Size	Applicable pressure (kgf/cm <sup>2</sup> g)	Structure	Materials		End connection	Page
				Body	Disc, seat		
YAF-14S	15(1/2")~50(2")	Maximum 14	Float type	GCD450		KS PT SCREW	70
YAF-14F						KS 10K RF FLANGE	
YBT-4	15(1/2")~25(1")	Maximum 17	Inverted bucket type	GC200	STS	KS PT SCREW	71
YSP-1, 2		0.35~12	Disc type				72
YSP-5		0.1~8 or 0.3~16	Disc type (Bimetallic)	STS			74
YSP-6		8(1/4")~10(3/8")	0.1~16	Disc type			75
YRS-3	15(1/2")~20(3/4")	0.1~1.5 or 1.5~3	Thermo-wax type	C3771			



# Type YAF-14S, 14F Ball Float Type Steam Trap

3

This is a lever float type steam trap that can be used where pressure is high and where a large volume of condensate is generated, such as heat exchangers, room heating and water heating facilities, and air-conditioning and heating facilities.



Type YAF-14S



Type YAF-14F

## ■ Features

- Outstanding performance in continuous discharge, regardless of load fluctuations of condensate.
- Built-in automatic Air Vent ensuring no air binding.
- Easy repair and inspections : simply remove the cover for repair and inspections. The float assembly is attached to the cover.

## ■ Specifications

Type	YAF-14S	YAF-14F
Size	15, 20, 25, 32, 40, 50A	
Applicable pressure	4.5, 10, 14kgf/cm <sup>2</sup> g	
Applicable temperature	220° C below	
End connection	KS PT SCREW	KS 10K RF FLANGE
Materials	Body	GCD450
	Seat	STS
	Float, lever	STS
	Air vent	Bimetals
Hydraulic test pressure	1.5 times of applicable flange rating	

## ■ Maximum applicable differential pressure

Type	Differential pressure (kgf/cm <sup>2</sup> )
YAF-14(4.5)	4.5
YAF-14(10)	10
YAF-14(14)	14

## ■ Dimensions

(mm)

Size	L	H1	H2	A	Weight(kg)
15(1/2")	122 (170)	61	61	147	2.9
20(3/4")	122 (170)	61	61	147	2.9
25(1")	122 (200)	67.5	108	223	6.8
32(1 1/4")	160 (210)	67.5	108	238	7.2
40(1 1/2")	270 (270)	80.5	125.5	285	17.5
50(2")	300 (300)	90	142	295	22.0

▶ The dimensions in parenthesis are for YAF-14F.

## ■ Dimensional drawing

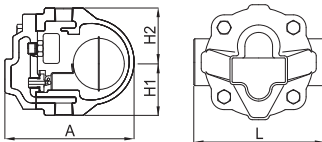

15, 20A

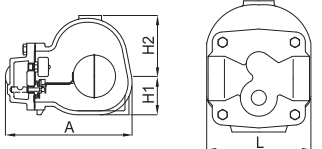

25, 32A

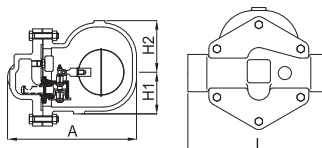

40, 50A

## ■ Size selection chart

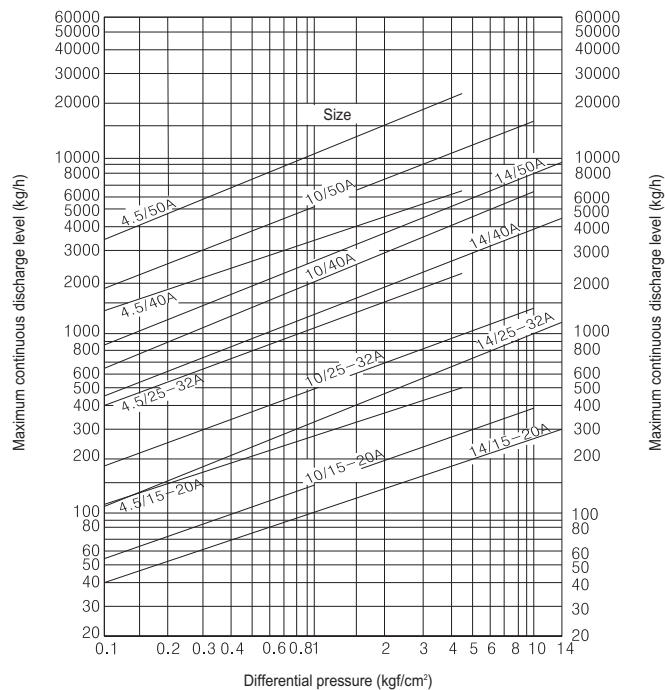

# YBT-4 Bucket Trap

As an optimal trap for drain discharge for steam pipelines and headers, it has a simple structure that ensures easy maintenance.



## ■ Features

- Simple structure & extremely strong parts : durability and effective operations are guaranteed.
- No air binding : inverted structure of the bucket.
- No need to attach a separate strainer : bucket trap with built-in screen.
- Easy repair : simply remove the cover.

## ■ Specifications

Type	YBT-4
Applicable pressure	Maximum 17 kgf/cm <sup>2</sup> g
Fluid temperature	220° C below
End connection	KS PT SCREW
Materials	Body
	Disc, seat
Hydraulic test pressure	25 kgf/cm <sup>2</sup> g

## ■ Maximum applicable differential pressure

Size	Applicable differential pressure (Psi)
15(1/2")	80 / 125 / 230
20(3/4")	
25(1")	

## ■ Dimensions

(mm)

Size	L	H1	H2	D	Weight(kg)
15(1/2")	127	78	65	1/2"	2.7
20(3/4")	127	78	65	3/4"	2.7
25(1")	127	100	65	1"	3.0

## ■ Cautions during installation

- After installing a bypass line and before operating the trap, blow out and remove foreign substances from inside the pipeline.
- The trap should be installed horizontally.
- The location of trap installation in the pipeline should be the lowest point of the facility or the end of the pipeline. If the outlet side is vertically standing, the height of the trap should be within the allowed back pressure range.

## ■ Dimensional drawing

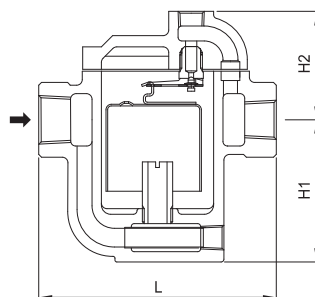

## ■ Flow curve

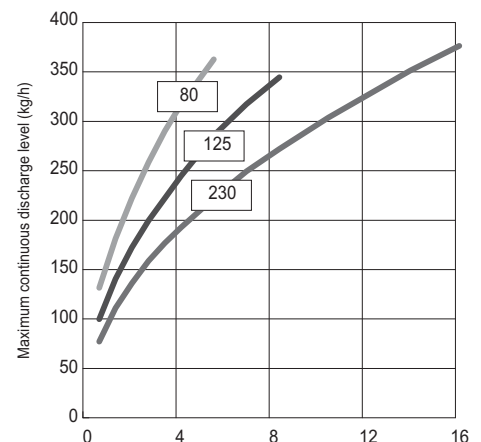



# Type YSP-1, 2 Disc Steam Trap (Pipeline)

3

As a disc type trap, it effectively uses the difference in the thermodynamic characteristics between steam and condensate. It is appropriate for places where there is a high possibility of freezing damages, including where the outlet or a steam main is exposed to the atmosphere.



Type YSP-1



Type YSP-2

## ■ Features

- Economical Trap (YSP-1 : no need for a separate bypass pipeline & simple handle operation blows foreign substances out and discharges condensed water.)
- No air binding during the start-up & easy repair.
- Easy installation in a pipeline : compact product & either the screwed type or flanged type can be used according to installation conditions.

## ■ Specifications

Type		YSP-1, YSP-2
Applicable pressure		0.35~12kgf/cm <sup>2</sup> g
Fluid temperature		220° C below
End connection		KS PT SCREW
Materials	Body	GC200
	Disc, seat	STS
Hydraulic test pressure		18 kgf/cm <sup>2</sup> g

## ■ Dimensions

Type	Size	L	H1	H2	Weight(kg)
Type YSP-1	15(1/2")	120	33	95	2.0
	20(3/4")	125	33	95	2.0
	25(1")	135	37	97	2.6
Type YSP-2	15(1/2")	80	33	84	1.5
	20(3/4")	84	33	84	1.5
	25(1")	88	37	87	2.0

## ■ Flow curve

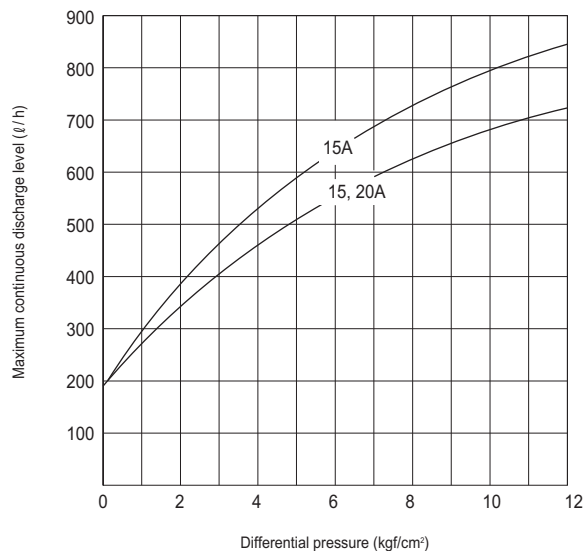

## ■ Dimensional drawing

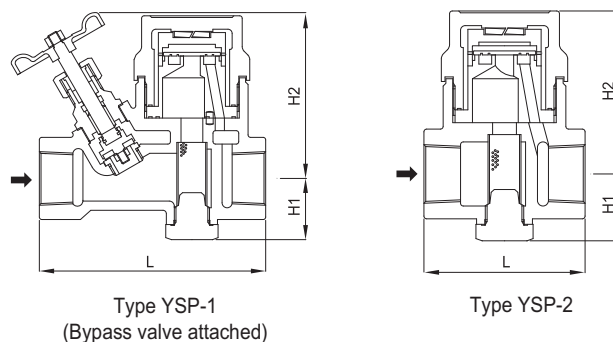

# Type YSP-1, 2 Disc Steam Trap (Pipeline)

## © Type YSP-1 Steam Trap for Bypass

### ■ Features

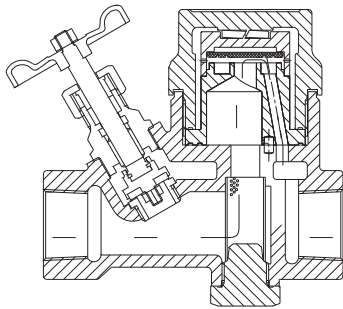

When the bypass valve is closed

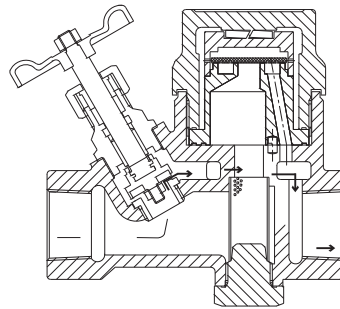

When the bypass valve is open

- 2 different functions : (1) Trap-when the bypass valve is closed; (2) Condensed water discharge device-when the bypass valve is open.
- Built-in strainer.
- No need for a bypass pipeline.
- Simple structure : easy operation & repair.

### ■ Pipeline installation method

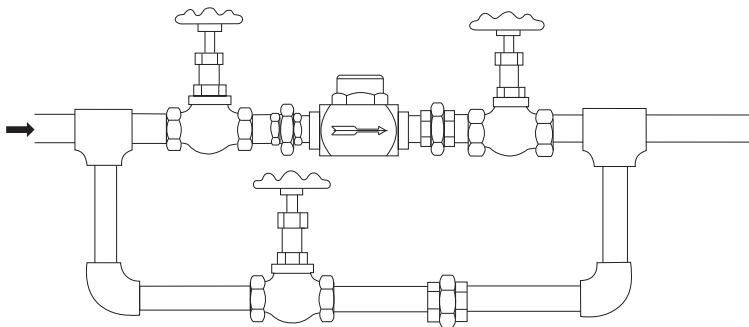

When a bypass steam trap is not attached

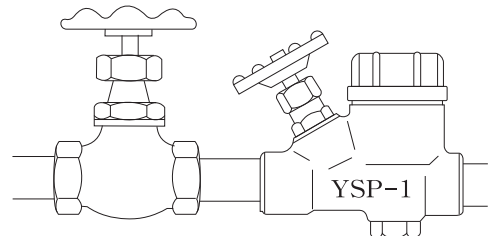

When a bypass steam trap is attached



# Type YSP-5 Steam Trap

3

As a disc type trap, this product guarantees perfect operations and features parts that are all made of highly durable stainless steel. Because it has a built-in bimetal, there is no air binding and no concern of freezing damages.



### ■ Dimensional drawing

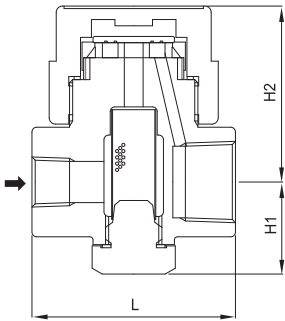

### ■ Features

- Built-in bimetal preventing air binding.
- Built-in strainer preventing malfunctioning caused by foreign substances.
- Made of stainless steel : outstanding durability and a high degree of hardness.

### ■ Specifications

Type		YSP-5
Applicable pressure		0.1~8, 0.3~16kgf/cm <sup>2</sup> g
Fluid temperature		220° C below
End connection		KS PT SCREW
Materials	Body	STS
	Disc, seat	STS
Hydraulic test pressure		24 kgf/cm <sup>2</sup> g

### ■ Dimensions

(mm)					
Type	Size	L	H1	H2	Weight(kg)
Type YSP-5	15(1/2")	65	30	55	1.0
	20(3/4")	65	30	55	1.0
	25(1")	65	30	55	1.2

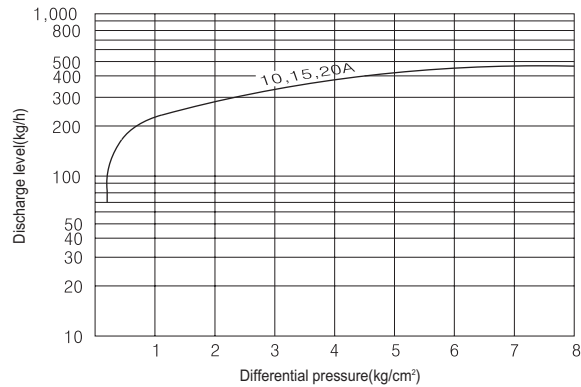

# Type YSP-6 Steam Trap

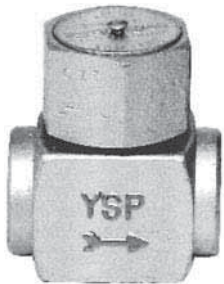

### ■ Dimensional drawing

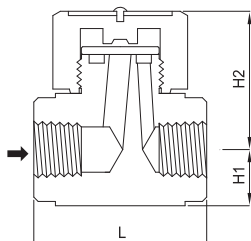

### ■ Features

- Compact & lightweight : easy to install.
- Superb discharge performance & a long life span.
- Made of stainless steel : a high degree of hardness & corrosion-free.

### ■ Specifications

Type		YSP-5
Applicable pressure		0.1~16kgf/cm <sup>2</sup> g
Fluid temperature		220° C or below
End connection		KS PT SCREW
Materials	Body	STS
	Disc, seat	STS
Hydraulic test pressure		24 kgf/cm <sup>2</sup> g

### ■ Dimensions

(mm)					
Size	L	H1	H2	Weight(kg)	
6(1/4")	40	13	32	0.23	
9(3/8")	40	13	32	0.23	

# Type YRS-3 Radiator Trap

This is a thermo-wax type radiator trap that is used for heating radiators.



## ■ Features

- No concern about freezing damages : no condensate remaining in the trap.
- No steam leakage : discharging condensate only when it is 100°C or below.
- Quickly discharging condensate and air.
- Compact & strong : The product can be used almost permanently. If needed, just replace the element.
- Distance among surfaces and the union nipple part - Same regulations on heating radiator traps KS B 6403 are applied.

## ■ Specifications

Applicable pressure		0.1~1.5, 1.5~3kgf/cm <sup>2</sup> g
Fluid temperature		150° C below
End connection	Inlet	KS PT SCREW (Union nipple)
	Outlet	KS PT SCREW
Materials	Body	C3771
	Disc, seat	STS
Hydraulic test pressure		4.5 kgf/cm <sup>2</sup> g

## ■ Dimensions

Size	L	H1	H2	d	Weight(kg)
15(1/2")	80	35	40	1/2"	0.6
20(3/4")	87	41	40	3/4"	0.6

## ■ Flow curve

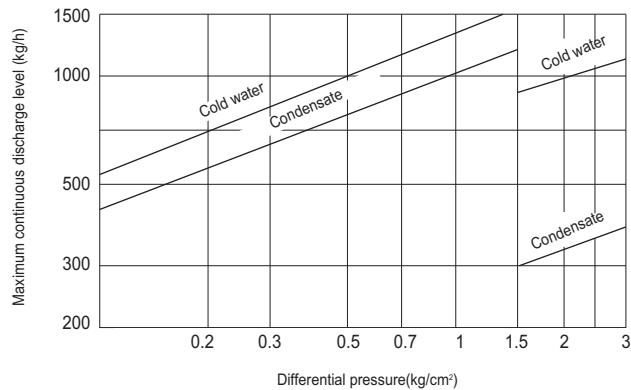

## ■ Dimensional drawing

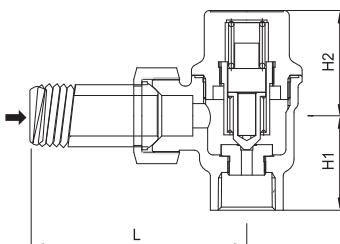

## ■ Changing the thermo element

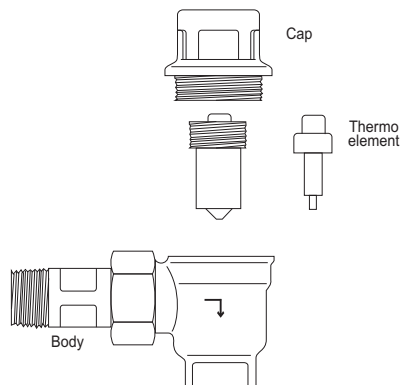

## ■ Installation example

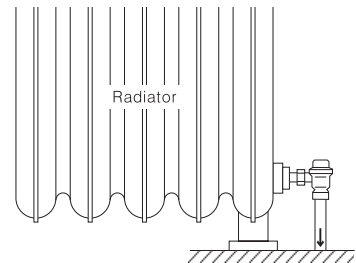

The element can be changed simply by loosening the cap.



# Data / Steam Trap

3

## ■ Steam characteristics and terminologies

### ● Steam curve

Water boils at 100°C when it is heated while placed in an open container.  
 When water inside an airtight container is heated, the pressure rises and the saturation temperature goes up as well.  
 Diagram 1 shows the relationship between pressure and temperature.

› Diagram 1. Steam curve

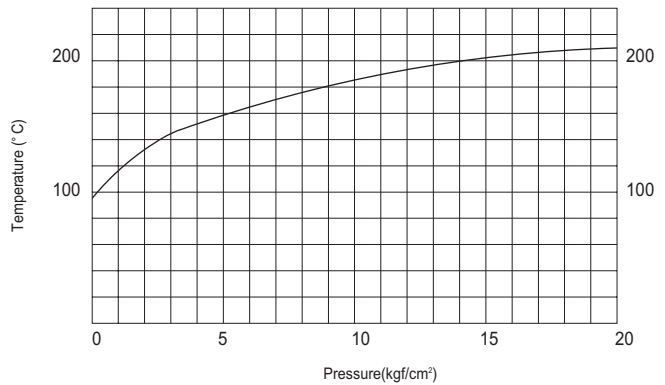

### ● Heat

- Sensible heat: Heat required to heat a unit weight of water so that it reaches the saturation temperature, while the pressure remains constant.
- Latent heat: Heat required to convert a unit weight of saturated water in saturation temperature state into saturated steam. (Also referred to as evaporation heat.)
- Super heat: Heat required to convert a unit weight of saturated steam into super heated steam.
- Total heat: Total heat that steam has in a certain state.
- Diagram 2 shows the relationship between temperature and heat.

› Diagram 2. Heat curve

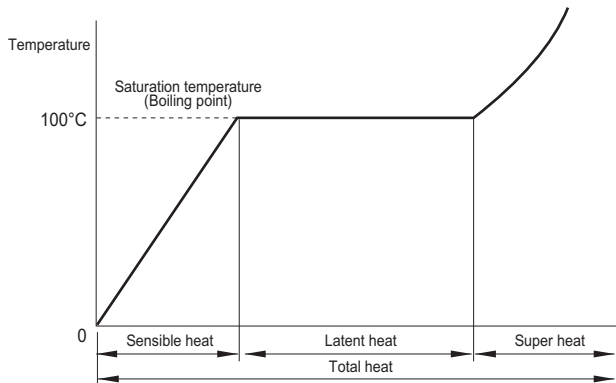

### ● Operation-related terminologies

<b>Operating Pressure</b>	Pressure on the inlet side of a trap
<b>Back Pressure</b>	Pressure on the outlet side of a trap
<b>Differential Pressure</b>	Difference between the operating pressure and back pressure
<b>Operating Temperature</b>	Temperature on the inlet side of the trap under operating conditions
<b>Maximum Operating Temperature</b>	Maximum temperature allowed for the inlet side of a trap
<b>Maximum Operating Pressure</b>	Maximum pressure allowed for the inlet side of a trap

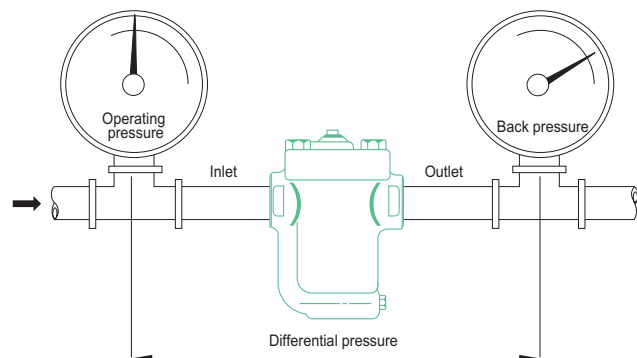

# Data / Steam Trap

## ■ Types of steam traps

### ● Functions of a steam trap

A steam trap should quickly discharge condensate, air, and CO<sup>2</sup> gas from a steam system, and should not leak live steam.

### ● Types of steam traps

Category	Type
Mechanical Steam Trap	1. Float Trap 2. Inverted Bucket Trap 3. Open Bucket Trap
Thermostatic Steam Trap	1. Bellows Trap 2. Thermo Wax Trap 3. Bimetallic Trap
Thermodynamic Steam Trap	1. Disc Trap

### ● Comparison of characteristics among different trap types

Category Characteristics		Inverted bucket trap	Float trap	Disc trap	Thermostatic trap
		YBT-4	YAF-14	YSP-1, 2 YSP-5, 6	YRS-3
1	Operation cycle	Intermittent operation	Continuous operation	Intermittent operation	Continuous operation
2	Energy conservation (during operation)	○	○	×	●
3	Abrasion resistance	●	●	○	●
4	Corrosion resistance	●	●	●	●
5	Fluid's impact resistance	○	×	●	●
6	Discharge of air and CO <sup>2</sup> at steam temperature	○	×	×	×
7	Air discharge capability at ultra low pressure (0.117 kgf/cm <sup>2</sup> g)	×	●	×	●
8	Air load handling capability during start-up	○	●	×	●
9	Operation based on back pressure	●	●	×	●
10	Freezing resistance	○	×	●	●
11	Operation performance in terms of small load	○	●	×	●
12	Hindrance by foreign substances	●	●	×	●
13	External size	Large	Large	Small	Small
14	Re-evaporated steam handling capability	○	×	×	●
15	Orifice closing state before operation	Open	Closed	Closed	Open
Legend		● Excellent    ○ Good    × Open			



# Data / Steam Trap

## ■ Steam trap selection

3

### ● Selection of a type

Steam traps have different characteristics according to their type. This is why there is a need to first decide on a specific type when selecting a steam trap.

A type should be selected based on past experience. For details, review informational materials and consult with the manufacturer.

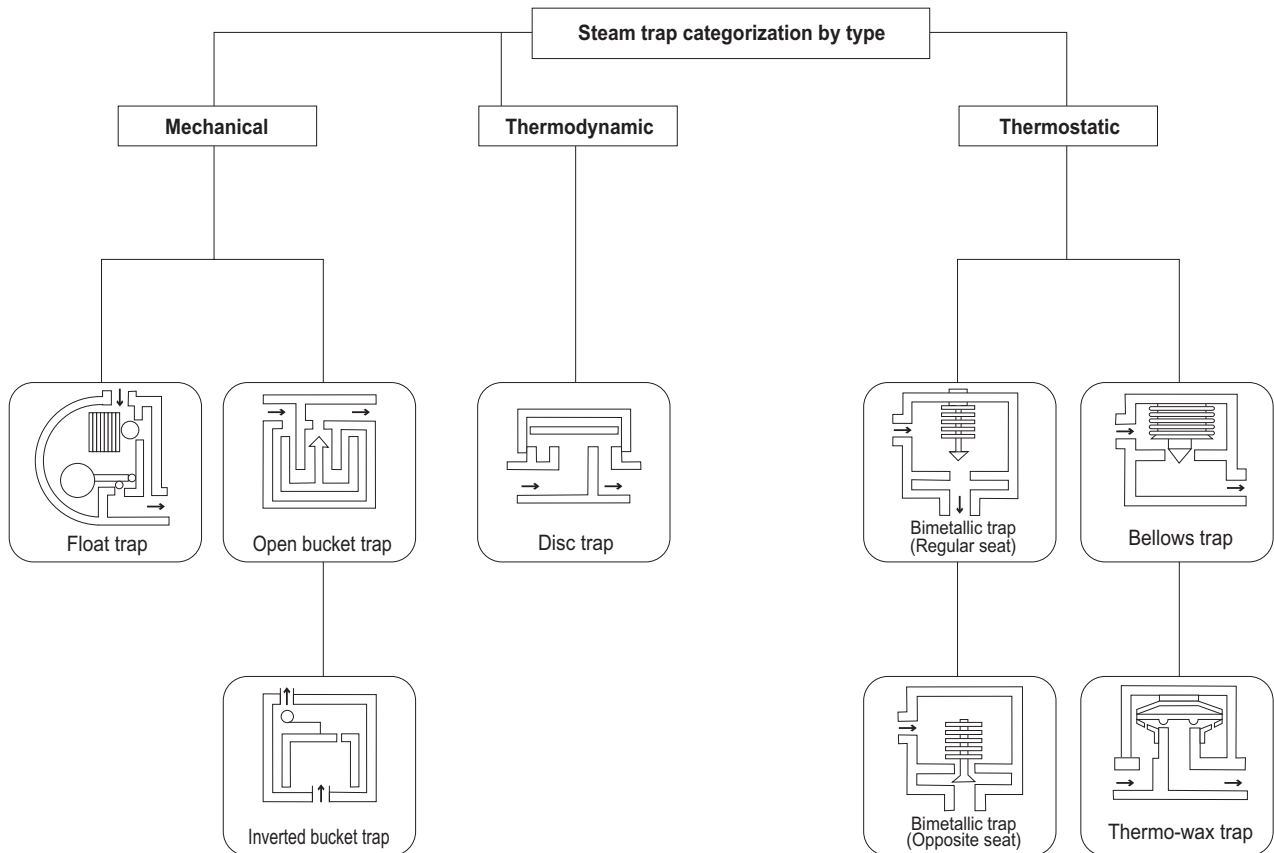

### ● Selection of a size

A decision on a size of a steam trap should be made in consideration of the generated condensate amount, differential pressure, back pressure, and safety factor of steam equipment.

#### 1) How to calculate the generated condensate amount

- Materials provided by the steam equipment manufacturer
- Calculation using a formula

$$W = \frac{Q \cdot \Delta T \cdot C_p}{L}$$

W : Generated condensate amount (kg/h)

Q : Heated liquid flow (kg/h)

$\Delta P$  : Temperature increase (°C)

C<sub>p</sub> : Specific heat (kcal/kg°C)

L : Heat reduction of steam (kcal/kg)

#### 2) Differential pressure: Difference in pressure (back pressure) between the inlet side and outlet side of a trap

#### 3) Safety factor: Apply a safety factor to steam equipment by considering the maximum condensate load during initial operation.

#### » Safety factor of different types of equipments

Steam main	3
Heat exchanger	2
Tracing line	2
Heating facility	3

# Data / Steam Trap

## ■ Cautionary measures for trap installation and examples of installation in a pipeline

### ● Cautions for trap installation

- Remove scales, dust, etc. from the pipeline before installing a trap.
- Install the trap where easy maintenance and inspections can take place.
- Install the trap near the steam equipment.
- Have the pipeline inclined so that condensate flows into the trap by force of gravity.

### ● Application Diagram (Example)

#### » In case of inlet side

Example of a good case	Example of a bad case	Explanation
		Install the trap on the inlet side to improve the performance of an automatic valve, including a pressure reducing valve.
		In case of steam main, install the trap in the pipeline after installing a pocket.
		Install the trap at the lowest end of the steam equipment.
		If there is more than one steam equipment, install a trap for each.
		Avoid parallel pipeline installation of steam traps.

#### » In case of outlet side

Example of a good case	Example of a bad case	Explanation
		If the outlet side is vertically standing, connect the trap on the upper part of the water collecting tube.
		The pipe size of the condensate collecting tube should be bigger than the sum of the cross sections of the trap pipeline.
		Install separate water collecting tubes for steam usage areas that have a different pressure level (of at least 50%).
		The outlet side of the trap should be at a higher location than the water level of the condensate tank.



# Data / Steam Trap

## ■ Troubleshooting

3

### 1) Bucket trap (YBT-4)

Troubles	Possible reasons	Measures
Not discharging	The running pressure is higher than the trap's applicable pressure. The orifice is clogged due to foreign substances.	Replace the trap with another one that has an appropriate pressure level. Disassemble and clean.
Small discharge volume	There is insufficient discharge capacity. The operating differential pressure is insufficient due to excessive back pressure.	Replace the trap with another one that has enough capacity. Check the pressure level on the inlet and outlet side of the trap and the piping system.
Steam leakage	There is a foreign substance in between the disc and seat. The disc and seat are worn. The bypass valve is defective.	Disassemble and clean. Change the disc and seat. Check or replace the bypass valve.

### 2) Float trap (YAF-14S, YAF-14F)

Troubles	Possible reasons	Measures
Not discharging	The float has been damaged. The running pressure is higher than the trap's applicable pressure.	Change the float. Replace the trap with another one that has an appropriate pressure level.
Small discharge volume	The trap does not have enough discharge capacity. The operating differential pressure is insufficient due to excessive back pressure. The strainer on the inlet side of the trap is clogged.	Replace the trap with the one that has enough capacity. Check the pressure level on the inlet and outlet side of the trap and the piping system. Disassemble and clean.
Steam leakage	There is a foreign substance in between the disc and seat. There is a foreign substance in the air vent valve or the valve has been damaged. The bypass valve is defective.	Disassemble and clean the disc and seat. Check or replace the air vent valve.

### 3) Disc trap (YSP-1,2, YSP-5,6)

Troubles	Possible reasons	Measures
Not discharging	The trap's operating differential pressure is insufficient. The back pressure is high because the outlet side is vertically standing. The trap's discharge capacity is insufficient. The strainer on the inlet side is clogged.	Check the pressure on the inlet and outlet side of the trap. Check the piping system. Replace the trap with the one that has enough capacity. Disassemble and clean.
Small discharge volume	There is a foreign substance in between the disc and seat. The disc and seat are worn. The bypass valve is defective.	Disassemble and clean. Disassemble and polish, or replace the disc and seat. Check or replace the bypass valve.
Steam leakage	The back pressure is excessive. The running pressure is lower than the trap's minimum operating pressure.	Check the piping patterns on the outlet side. Replace the trap with a more appropriate one.

# Control Valves for District Cooling and Heating

# 4

## Control Valves for District Cooling and Heating

As valves used in construction facilities for cooling and heating, they comprise automatic flow control valves (per household, per apartment building), constant flow temperature control valves, differential pressure flow control valves, and differential pressure control valves.

### Automatic flow control valves

Type	Size	Applicable pressure (kgf/cm <sup>2</sup> )	Operating differential pressure range (kgf/cm <sup>2</sup> )	Structure	Materials		End connection	Page
					Body	Disc, seat		
YFC-2N	15(1/2")~50(2")	Maximum 10	0.3~5.0	Automatic balancing (per household)	BsC1	C3604BE	KS PT SCREW	82
YFC-1S	32(1 1/4")~50(2")		0.15~1.5	Automatic balancing	C3604	STS		KS PT SCREW
YFC-1F	50(2")~200(8")		0.3~4		SPPS		KS 10K FF FLANGE	
YFC-2F			0.5~7		GC200		KS 10K RF FLANGE	
YFC-20F		0.5~10	SCPH2	KS 20K RF FLANGE				
YBC-2F	50(2")~200(8")	Maximum 20	0.5~20	Manual balancing	GC200	KS 10K RF FLANGE	86	
YBC-20F	50(2")~200(8")	Maximum 10	Manual balancing		SCPH2			KS 20K RF FLANGE
YBC-20F	50(2")~200(8")	Maximum 20			SCPH2	KS 20K RF FLANGE		

### Constant flow temperature control valves

Type	Size	Applicable pressure (kgf/cm <sup>2</sup> )	Operating differential pressure range(kgf/cm <sup>2</sup> )	Structure	Materials		End connection	Page
					Body	Disc, seat		
YTF-20	15(1/2")~25(1")	Maximum 10	0.3~5.0	Diaphragm type	BsC3	EPDM	Inlet : KS PT Screw Outlet : KS PT Union	89
YFC-20				EPDM,VITION				
YTC-20	15(1/2")~20(3/4")	Direct operating type	C3771					

### Differential pressure flow control valves

Type	Size	Applicable pressure (kgf/cm <sup>2</sup> )	Operating differential pressure range (kgf/cm <sup>2</sup> )	Structure	Materials		End connection	Page
					Body	Disc, seat		
YDF-2F	25(1")~150(6")	Maximum 10	0.1~1.5	Diaphragm type	GC200	C3604	KS 10K RF Flange	90
YDF-20F			0.5~2.1					
		1.5~5.0						
DR-08 (Control)	25~25A	Maximum 10	0.05~0.3	Diaphragm type	BS	BS	-	92
DR-08 (Fixing)	25~25A		0.17					

### Differential pressure control valves

Type	Size	Applicable pressure (kgf/cm <sup>2</sup> )	Operating differential pressure range (kgf/cm <sup>2</sup> )	Structure	Materials		End connection	Page		
					Body	Disc, seat				
YDP-1F	25(1")~150(6")	Maximum 10	0.05~1.0	Diaphragm type Direct operating type	GC200	BC6	KS 10K RF Flange	93		
YDP-20F			0.5~2.0						SCPH2	KS 20K RF Flange
			1.5~5							
YDP-20F		Maximum 20	0.05~1.0							
			0.5~2.0							
	1.5~5									

# Type YFC-2N Automatic Flow Control Valve (per Household)

An automatic flow control valve per household limits the maximum flow, thereby distributing an appropriate flow to each place of use. It maintains the flow balance of each place of use by automatically adjusting the flow during the instrument's constant flow rate operations, thereby stabilizing the overall system.



## ■ Features

- Perfect Pressure-Balancing Type valve: it can be used independently from pressure changes, etc.
- Diaphragm operation method, instead of the usual cartridge method : less set flow variation.
- Variable flow control function : easy to change and adjust the set flow on the field, without disassembling.
- The employment of an optimal design for fluid flow reduces noise and vibration.
- Structure that allows a constant flow is only slightly affected by foreign substances and ensures easy disassembling and maintenance.
- Easy to remove foreign substances, thanks to an embedded strainer in the valve union.
- Easy to select a piping direction since both sides of the product are set up with unions.

## ■ Specifications

Type		YFC-2N (per household)
Applicable fluid		Cold/hot water
Automatic differential pressure range		0.3~5kgf/cm <sup>2</sup>
Flow variation		±2.5%~±5% of set flow
Fluid temperature		120° C below
End connection	Inlet	KS PT UNION
	Outlet	KS PT UNION(15A, 20A, 25A), SCREW(32A, 40A, 50A)
Material	Body	BsC3
	Disc	C3604BE
	Diaphragm	EPDM
Hydraulic test pressure		15 kgf/cm <sup>2</sup>

- ▶ Made-to-orders for unions are available only for the inlet or outlet side.
- ▶ Strainer (over 40 Mesh ) installation is required to ahead inlet when valve installing.

## ■ Dimensions

Category	Size	L	H1	H2
Standard	15(1/2")	134	47	41.5
	20(3/4")	134	47	41.5
	25(1")	150	51	41.5
	32(1 1/4")	114	45	60
	40(1 1/2")	132	55	69
	50(2")	165	60	83
Large flow	15(1/2")	95	39	49
	20(3/4")	95	39	49
	25(1")	100	39	49

## ■ Dimensional drawing

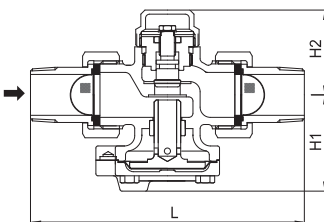

## ■ Flow setting range

Category	Size	Applicable differential pressure range	Flow setting range
Standard	15(1/2")	0.3~0.8	1.5~10
	20(3/4")		1.5~10
	25(1")		1.5~14
	32(1 1/4")	0.3~3.0	5~40
	40(1 1/2")		10~60
	50(2")		16~80
Large flow	15(1/2")	0.3~0.8	20
	20(3/4")		30
	25(1")		30

# Type YFC-2N Automatic Flow Control Valve (per Household)

## ■ Control range (Constant flow control valve for household)

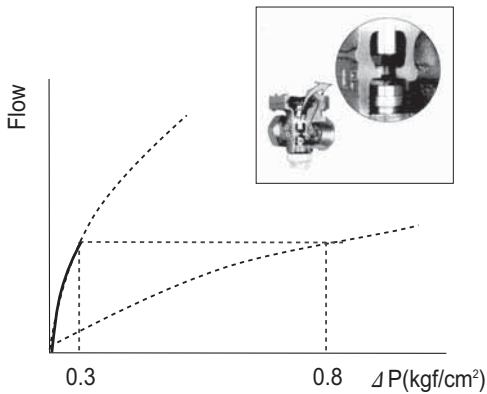

- When it is smaller than the automatic differential pressure range of an automatic flow control valve

Because the differential pressure is low, the pressure level is smaller than the pressure needed to actuate an automatic flow control valve. If actuated below the 0.3 kgf/cm<sup>2</sup> range, the automatic flow control valve is a normal open type. This is why the flow proportionally increases to a maximum of 0.3 kgf/cm<sup>2</sup>, which is the operating differential pressure range, according to an increase in differential pressure.

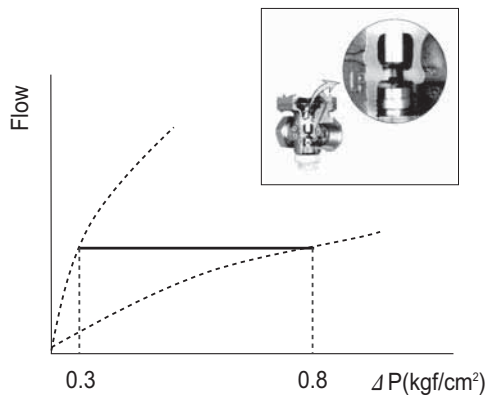

- When it is within the automatic differential pressure range of an automatic flow control valve

The differential pressure within the pipeline is within the pressure range needed to actuate an automatic flow control valve. Within the range of 0.3 kgf/cm<sup>2</sup>, a constant flow level is maintained within  $\pm 2.5\text{--}5.0\%$  of the set flow, based on pressure balancing of the pressure regulating spring and diaphragm, according to differential pressure fluctuations.

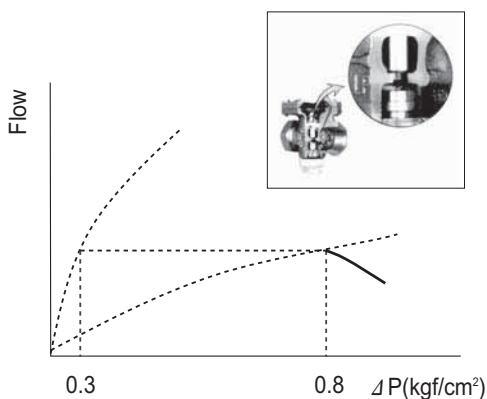

- When it is higher than the operating differential pressure range of an automatic flow control valve

As pressure (at least 0.8 kgf/cm<sup>2</sup>) that is higher than the operating differential pressure range is delivered to the upper part of the diaphragm, the valve slowly closes and the flow decreases according to an increase in differential pressure.

# Type YFC-1S, 1F Constant Flow Control Valve

What is needed for effective and efficient use of heating energy in tandem with the diversification of buildings is enhancing thermal efficiency by automatically controlling the appropriate flow of each piping system and thus supplying precisely based on the designed flow value. Samyang's type YFC-1 is the most cost-effective and practical product that features a wide array of functions as a constant flow control valve.

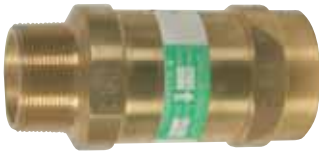

Type YFC-1S



Type YFC-1F

## ■ Features

- Free from troubles, abrasion and corrosion thanks to an extremely simple structure.
- Can be installed in any direction-horizontally, vertically, or acutely and almost no flow changes resulting from the installation direction.
- Offer a wide selection range for the set flow, and maintains an outstanding performance even in case of a water hammer, vibration, or rapid pressure changes.
- Can be easily handled and installation costs are extremely low.

## ■ Specifications

Type	YFC-1S	YFC-1F
Size	32~50A	50~200A
Automatic differential pressure range	0.15~1.5kgf/cm <sup>2</sup> , 0.3~4kgf/cm <sup>2</sup> , 0.5~7kgf/cm <sup>2</sup>	
Applicable fluid	Cold/hot water	
Fluid temperature	300° C below	
Flow variation	±5% of set flow	
End connection	KS PT SCREW	KS 10K FLANGE
Materials	Body	C3604
	Main part	STS
Hydraulic test pressure	15 kgf/cm <sup>2</sup>	

## ■ Dimensions

### » YFC-1S

(mm)

Size	L	Weight(kg)	Differential pressure range (kgf/cm <sup>2</sup> )	Flow (LPM)
32(1¼")	120	2.2	0.15~1.5 (0.3~4)	14~65 (20~65)
40(1½")	145	2.5		30~130 (50~130)
50(2")	164	2.9		50~250 (80~250)

### » YFC-1F

(mm)

Size	L	Weight(kg)	Differential pressure range (kgf/cm <sup>2</sup> )	Flow (LPM)
50(2")	165	10	0.3~7	59~360
65(2½")	205	12		100~600
80(3")	225	13		150~700
100(4")	290	16.5		235~1000
125(5")	335	26		368~1200
150(6")	335	37		530~2000
200(8")	450	49		940~3500

## ■ Dimensional drawing

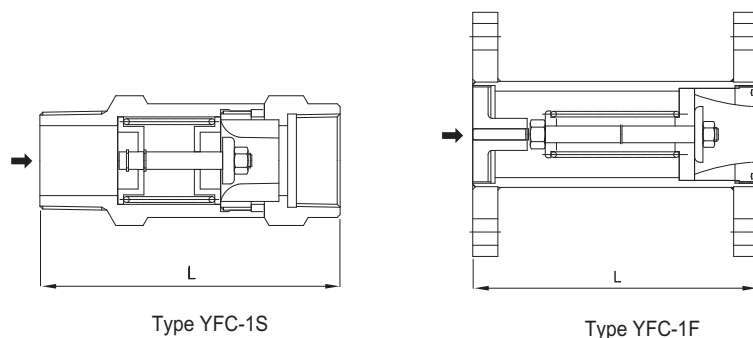

# Type YFC-1S, 1F Constant Flow Control Valve

## ■ Features

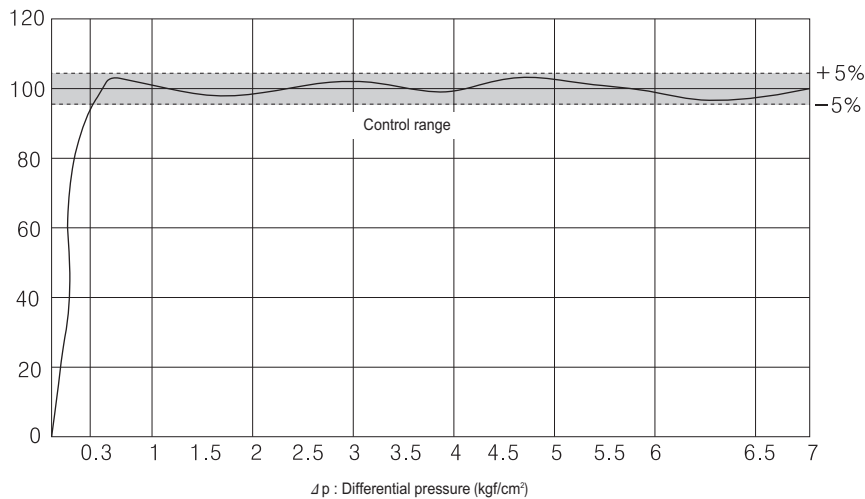

As seen in the chart above, if the differential pressure ( $\Delta p$ ) remains within the range of 0.3 to 7 kgf/cm<sup>2</sup>, a constant flow is maintained, with flow changes that are within  $\pm 5\%$ .

## ■ How it works

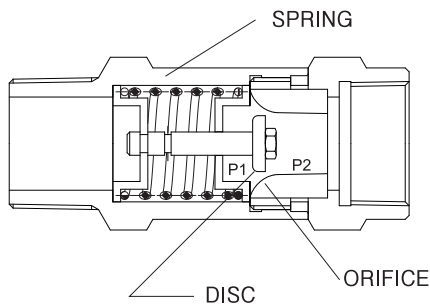

- The spring absorbs the differential pressure ( $\Delta p = P1 - P2$ ) between the front and rear of the disc that arises from the flow of fluid. The opening area of the orifice changes according to the spring's movements.
- It automatically adjusts the opening area to become smaller when the differential pressure increases as per increased flow velocity, and adjusts the opening to become bigger when the differential pressure decreases to maintain a constant flow.

## ■ How to control flow

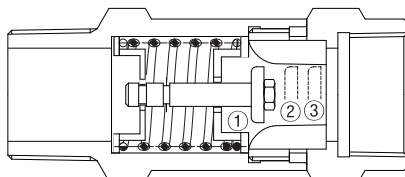

- Below the control range  
Because the disc is completely open by the spring, the opening area of the orifice reaches the maximum. When the valve is operated, the orifice area begins to decrease in proportion to the differential pressure, and thus the flow is controlled. (Case ①)
- Within the control range  
The opening area of the orifice is automatically adjusted according to changes in differential pressure between the front and rear of the disc. The valve precisely controls and maintains the flow within  $\pm 5\%$  of the designed flow. (Case ②)
- Over the control range  
If the differential pressure between the front and rear of the disc increases, resulting in excess of the control range, the spring is compressed as much as possible, resulting in the opening area of the orifice reaching its minimum. The flow thus remains at a fixed position in proportion to the differential pressure. (Case ③)

# Type YFC-2F, 20F Automatic Flow Control Valve

This product is suitable for places that require appropriate flow distribution, based on restriction on the maximum flow, and that require automatic flow restriction during constant flow rate operation of the instrument.



## ■ Features

- As a perfect balance type, it features outstanding control of the set flow in response to pressure fluctuations.
- Can be changed and adjusted on the field, and control range is wide.
- As a diaphragm type product, the range of applicable differential pressure is wide and superb in its ability to respond to rapid load fluctuations.
- The structure as a top-bottom separable type is simple and ensures easy handling, pipeline installation.

## ■ Specifications

Type	YFC-2F	YFC-20F	
Size	65~200A	65~200A	
Automatic differential pressure range	0.3~3kgf/cm <sup>2</sup>	0.5~5kgf/cm <sup>2</sup>	
Flow control range	5% of rated flow		
Applicable fluid	Cold/hot water, liquid		
Fluid temperature	150° C or below		
Flow variation	±5% of set flow		
Materials	Body	GC200	
	Disc, seat	STS	
	Diaphragm	EPDM	
End connection	KS 10K RF FLANGE	KS 20K RF FLANGE	
Hydraulic test pressure	1.5 time of applicable flange rating		

▶ Made-to-orders are available for valves with a size of 250 or larger.

## ■ Dimensions

(mm)

Type Size	YFC-2F				YFC-20F			
	L	H1	H2	Weight(kg)	L	H1	H2	Weight(kg)
65(2½")	276	185	548	50	292	140	720	55
80(3")	298	190	560	55	318	158	720	61
100(4")	352	200	567	69	368	160	735	78
125(5")	400	225	590	126	400	225	590	145
150(6")	451	263	625	158	473	263	625	197
200(8")	543	357	658	202	568	263	635	251

## ■ Dimensional drawing

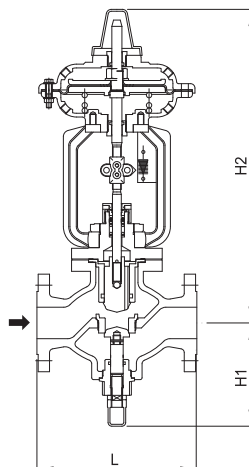

# Type YBC-2F, 20F Manual Balancing Valve

This product is suitable for places that manually restrict flow during constant flow rate operation of the instrument and that need to appropriately distribute flow based on restriction on the maximum flow.



Type YBC-2F

## Specifications

Type	YBC-2F	YBC-20F
Applicable fluid	Cold/hot water	
Applicable temperature	220°C or below	
Applicable pressure	Maximum 10 kgf/cm <sup>2</sup> g	Maximum 20 kgf/cm <sup>2</sup> g
End connection	KS PT 10K RF FLANGE	KS PT 20K RF FLANGE
Materials	Body	GC200
	Disc, seat	STS
Hydraulic test pressure	15 kgf/cm <sup>2</sup> g	30 kgf/cm <sup>2</sup> g

## Dimensions

Size	L	H1	H2	Cv	Weight(kg)
50(2")	254 (267)	95	355	43	31
65(2½")	276 (276)	115	380	58	39
80(3")	294 (294)	120	400	85.5	47
100(4")	352 (352)	130	420	128	61
125(5")	400 (410)	150	562	222	118
150(6")	451 (473)	180	592	324	150
200(8")	543 (568)	255	632	555	191

▶ The length values in parenthesis are for the type YBC-20F.

## Flow characteristics curve

### Linear characteristics

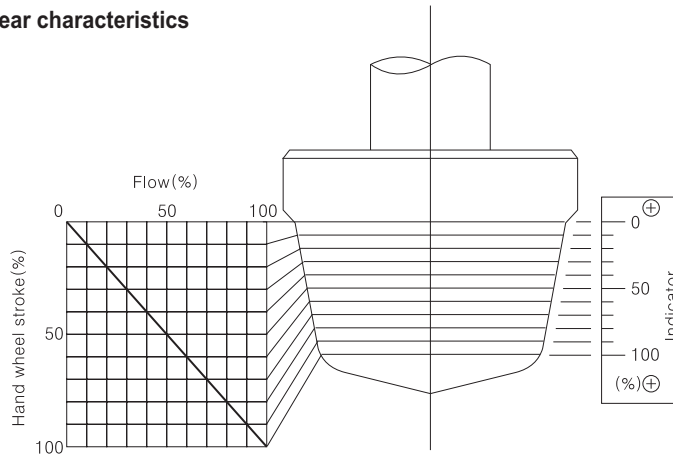

▶ If the valve stroke ratio is 50%, changes in the rated flow ratio are made as per the plug stroke ratio.

### EQ% characteristics

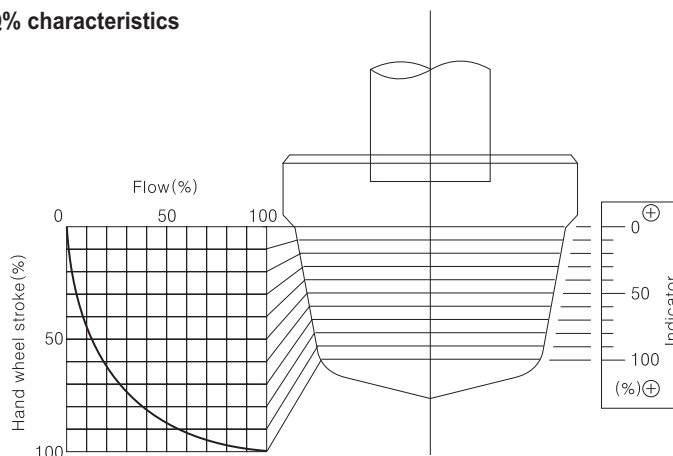

▶ Proximity to the close state entails precise throttling, while proximity to the open state entails a rapid flow increase. As such, it is also used for cases where it is forecasted that there will be substantial fluctuations in terms of pressure drop.

## Dimensional drawing

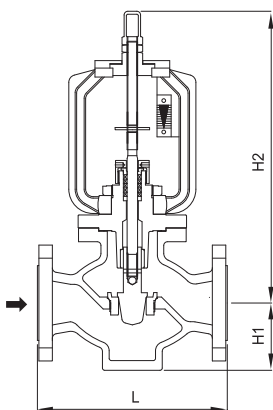

Type YBC-2F

# Type YBC-2F, 20F Manual Balancing Valve

## ■ Chart on selecting a flow and size

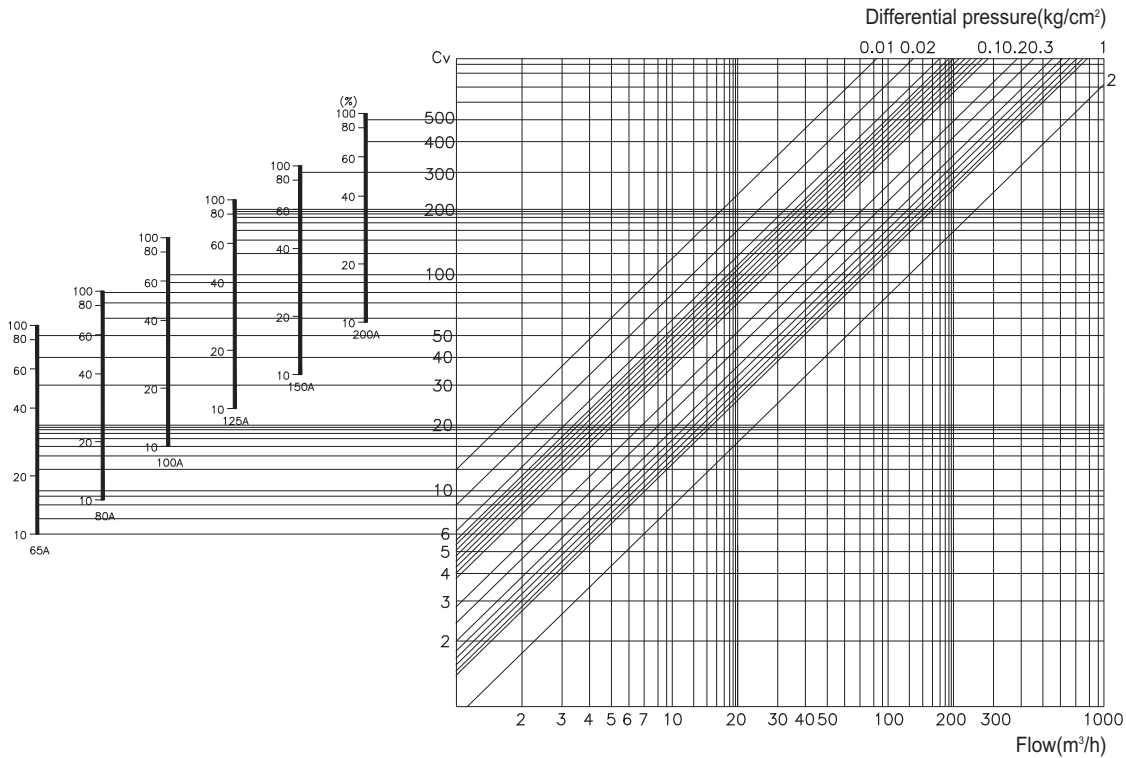

## ■ How to select by using a calculation formula

$$W = 0.8569 \times C_{v \max} \times k \times \sqrt{\Delta P}$$

$$W = \text{Flow (m}^3/\text{h)}$$

$C_{v \max}$  = Maximum Cv value of balancing valve

$k$  = Set graduation of indicator (%)

$\Delta P$  = Differential pressure between the valve's inlet and outlet (kgf/cm<sup>2</sup>)

(Example) Standard = 150A, Maximum Cv value = 324

$$W = 0.8569 \times 324 \times 0.4 \times \sqrt{0.03} = 19.2 \text{ m}^3/\text{h}$$

## How to set the flow using the chart

The maximum Cv value is 324 when the standard is 150A, which means that the Cv value becomes 129.6 when the indicator's adjustment is 40%. "A" is the point of intersection between this point and the line of the measured differential pressure between the valve's inlet and outlet (0.03). The flow at this point is 19.2 (m<sup>3</sup>/h).

# Type YTF-20, YFC-20, YTC-20 Constant Flow Temperature Control Valve

The constant flow temperature control valve is installed in a pipeline in the vicinity of a pan coil unit and hot water distributor within a household of a central and district heating system. It enhances energy efficiency by maintaining a selected temperature and controlling the flow.



YTF-20  
(Thermal type)



YTF-20  
(Electronic type)



Type YFC-20



YTC-20  
(Thermal type)



YTC-20  
(Electronic type)

## ■ Features

- Flexibly control a heat supply including a variable flow control function according to each household's need. (YTF-20, YFC-20)
- A diaphragm operation method ensures a less set flow variation from pressure fluctuations and prevents noise or vibration from the flow of fluid. (YTF-20, YFC-20)
- The attachment of a thermal actuator prevents vibration, noise during operation and can be used at a high differential pressure level. (YTF-20, YTC-20)
- Having a strainer attached, remove possibilities that leads to defects from foreign substances and ensures easy cleaning without tools. (YTF-20, YTC-20)
- A thermometer can be attached to allow for easy checking of the temperature of heat source water supplied to households. (YTF-20, YFC-20)
- The attachment of a stop valve saves construction costs and installation space. (YFC-20)

## ■ Specifications

Type	YTF-20	YFC-20	YTC-20
Applicable fluid	Cold/hot water		
Operating differential pressure range	0.3~0.8kgf/cm <sup>2</sup>		
Applicable fluid temperature	5~120° C		
Flow control range	15A, 20A : 1.5~10LPM	15A	
	25A : 1.5~14LPM		
End connection	Inlet	KS PT SCREW	
	Outlet	KS PT UNION	
Materials	Body : BsC3 / Diaphragm : EPDM / Body : C3771		
Hydraulic test pressure	15 kgf/cm <sup>2</sup>		

## ■ Dimensions

Type	Size	L	H	Weight (kg)
YTF-20	15(1/2")	148	128	1.2
	20(3/4")	148	128	1.3
	25(1")	159	134	2.0
YFC-20	15(1/2")	97	125	0.4
	20(3/4")	97	125	0.4
	25(1")	110	130	0.6
YTC-20	15(1/2")	92	85	0.4
	20(3/4")	92	100	0.4

▶ Strainer (over 40 Mesh ) installation is required to ahead inlet when valve installing.

## ■ Actuator specifications

	Thermal type	Electronic type
Form of operation	Normal Closed	Normal Closed
Rated voltage	AC 220V, 60Hz	AC 220V, 60Hz
Permissible differential pressure	4.5kgf/cm <sup>2</sup>	3.5kgf/cm <sup>2</sup>
Power consumption	3W	5W

## ■ Dimensional drawing

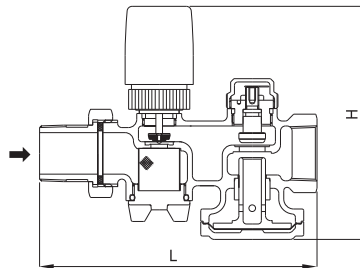

Type YFT-20

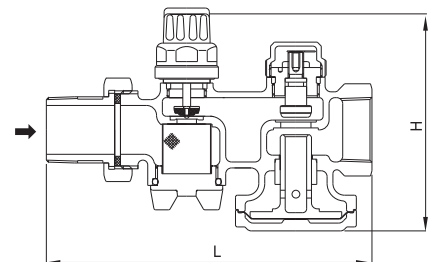

Type YFC-20

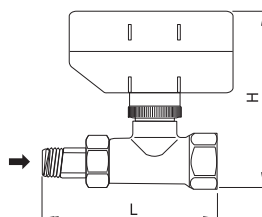

YTC-20 (Electronic type)

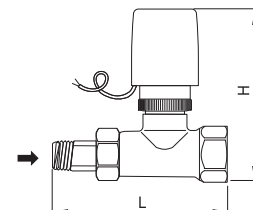

YTC-20 (Thermal type)

# Type YDF-2F, 20F Differential Pressure Flow Control Valve

This valve performs the two control functions of restricting flow and maintaining a differential pressure of supply and return lines. It can be installed in a supply line or return line according to its purpose of use.



Type YDF-2F



Type YDF-20F

### ■ Dimensional drawing

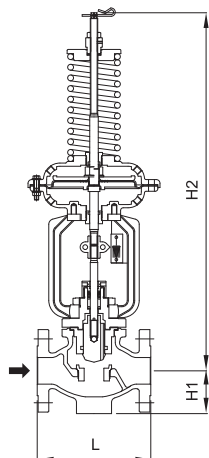

### ■ Features

- High-performing differential pressure flow control valve that is installed in a supply or return line of a load device to control the differential pressure and flow comprehensively.
- In addition to differential pressure control, it offers a wide flow control range, from small to large flows, thanks to an embedded equal % cone for flow control.
- The diaphragm is separated from the body and thus is not affected by temperature. Since it is a perfect balance type, the set differential pressure does not change due to pressure fluctuations.
- Has a solid structure, and thus offers an outstanding level of durability.
- A diaphragm method enables to be installed horizontally or vertically.
- The opening percentage of the valve can be easily checked, thanks to the attached indicator.
- Leakage from packings can be visually checked, enabling easy identification of the appropriate time for repair.

### ■ Specifications

Type	YDF-2F	YDF-20F
Applicable pressure	Maximum 10 kgf/cm <sup>2</sup> g	Maximum 20 kgf/cm <sup>2</sup> g
Applicable fluid	Cold/hot water	
Fluid temperature	Maximum 170° C	
Structure	DIAPHRAGM	
Differential pressure control range	0.1~0.7, 0.15~1.5, 1.5~5kgf/cm <sup>2</sup>	
Flow control range	0.5~100% of the constant flow rate	
End connection	KS 10K RF FLANGE	KS 20K RF FLANGE
Materials	Body	GC200
	Disc, seat	BC6
	Diaphragm	EPDM
Hydraulic test pressure	15 kgf/cm <sup>2</sup>	30 kgf/cm <sup>2</sup>

▶ The basic pressure regulating range is 0.15~1.5 kgf/cm<sup>2</sup>

### ■ Dimensions

(mm)

Type Size	YDF-2F				YDF-20F				Cv
	L	H1	H2	Weight (kg)	L	H1	H2	Weight (kg)	
25(1")	184	62.5	640	20	197	62.5	640	21	8
32(1¼")	180	70	650	26	180	70	650	26	12.5
40(1½")	222	80	658	28	235	80	658	30	18
50(2")	254	95	670	41	267	95	670	43	43
65(2½")	276	115	720	48	292	115	720	54	64
80(3")	294	120	720	56	318	120	720	65	84
100(4")	352	130	735	72	368	130	735	83	150
125(5")	400	150	775	130	400	150	775	152	200
150(6")	451	180	800	162	473	180	800	203	288

▶ Made-to-orders are available for valves with a size of 200 or larger.

### ■ Application Diagram (Example)

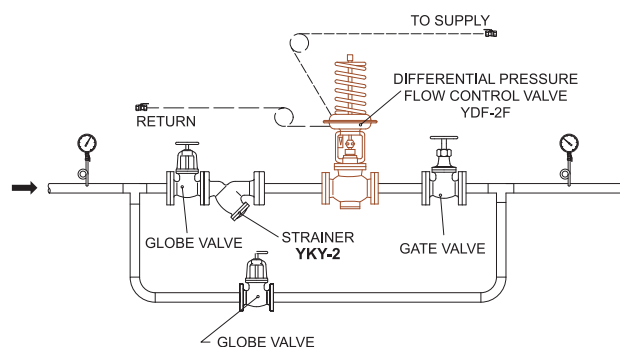

# Type YDF-2F, 20F Differential Pressure Flow Control Valve

## ■ Selection of a size

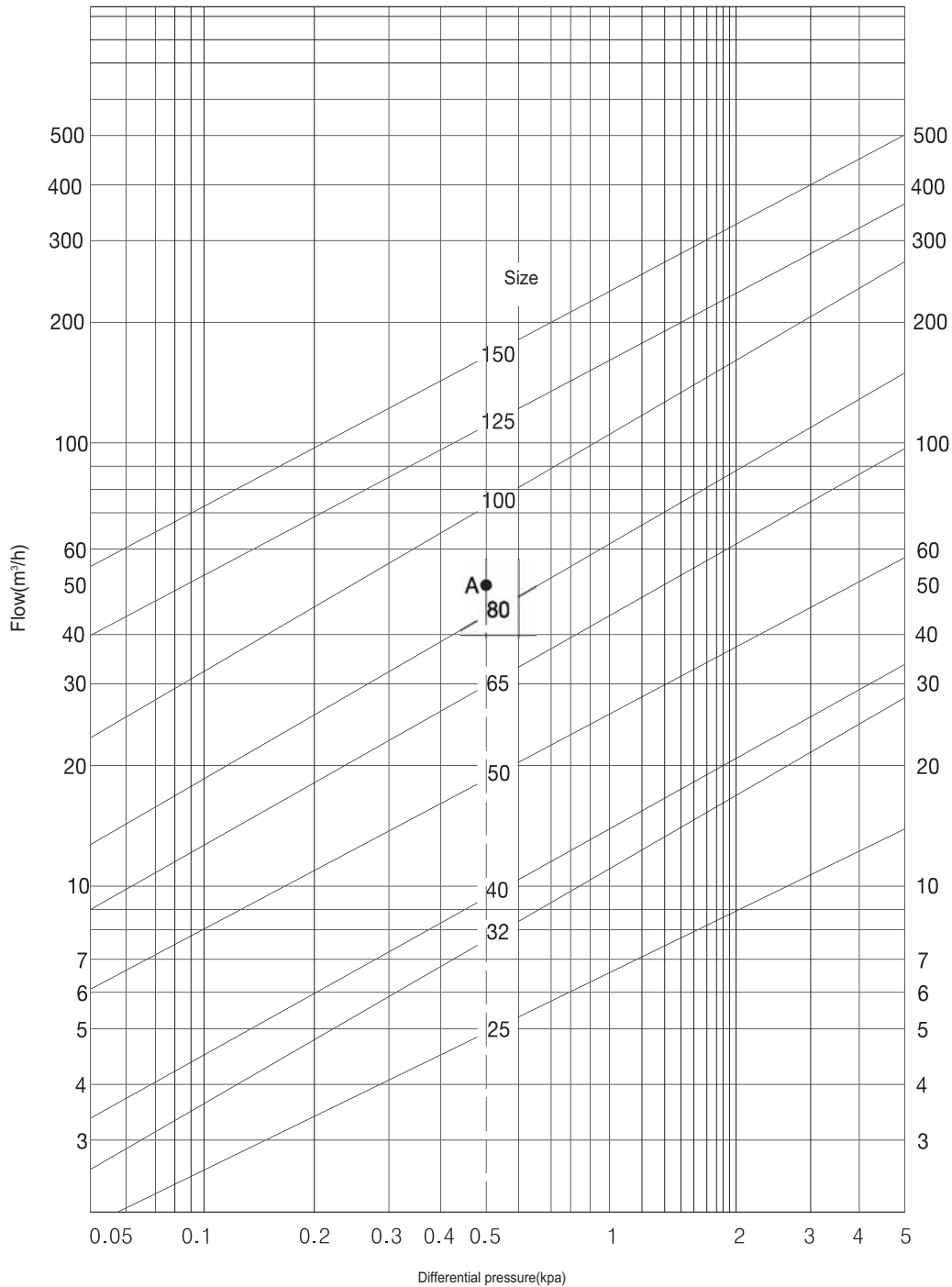

$$C_v = \frac{1.167 \times Q \times \sqrt{r}}{\sqrt{\Delta P}}$$

Here,  $C_v$ : Valve flow coefficient

$Q$ : Flow (m³/h)

$r$ : Density (Water =1)

$\Delta P$ : Pressure difference between the valve's inlet and outlet (kgf/cm²)

# Type DR-08 Differential Pressure Flow Control Valve

This valve is used for home heating systems of district and central heating systems. It maintains an appropriate flow for each zone (room) by detecting the pressure difference of the supply and return lines and controlling the flow when there are load fluctuations, according to the on and off state of each zone (room), in terms of the maximum flow within a household that was balanced based on the constant flow control valve of each household.



Differential pressure control type



Differential pressure fixing type

## ■ Features

- High-performing differential pressure flow control valve, Installed in a supply or return line of a load device, controls the differential pressure and flow comprehensively.
- Operates minutely and proportionally even without back-up energy supply.
- Prevents noise and excessive flow of a pipeline within a household.
- Offers superb durability with a solid structure.
- Can be applied to a wide variety of flow systems and temperature control systems.

## ■ Specifications

Type		Differential pressure control type	Differential pressure fixing type
Maximum pressure		Maximum 10 kgf/cm <sup>2</sup> g	
Differential pressure control range		0.05~0.3kgf/cm <sup>2</sup>	0.17kgf/cm <sup>2</sup>
Flow control range		CV=3.2	
Applicable temperature		110° C below	
Materials	Body	BS	
	Disc/Seat	BS	
	Diaphragm	EDPM	

## ■ Dimensions

Category	Size	(mm)	
		L	H
DR-08(Fixed type)	20(3/4")	82	108
	25(1")	82	108
DR-08(Variable type)	20(3/4")	82	112
	25(1")	82	112

## ■ How to adjust the differential pressure

Clockwise direction :  
Differential pressure increases



Counterclockwise direction :  
Differential pressure decreases

- If there is no request to do otherwise, the differential pressure is set to 0.17 kgf/cm<sup>2</sup> prior to product delivery.
- The following steps should be taken, in that order, when there is a need to adjust the differential pressure due to changes in field conditions.
  - a. Open all valves in a circulating pipeline and operate the pump. Read the differential pressure of the supply side and return side.
  - b. Slowly turn the adjustment nut clockwise and counterclockwise, while reading the pressure on the supply side and return side, and set a desired differential pressure.

## ■ Dimensional drawing

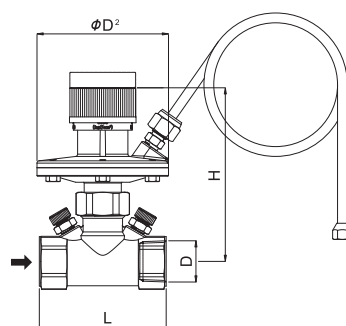

Differential pressure control type

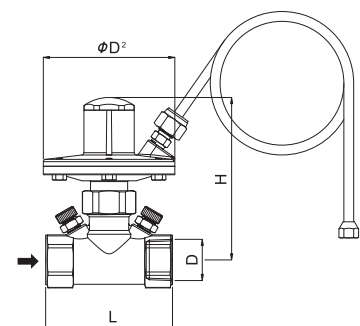

Differential pressure fixing type

# Type YDP-1F, 20F Differential Pressure Control Valve

This maintains the differential pressure of supply and return lines or the differential pressure of the inlet and outlet side of an instrument in a closed circuit.



Type YDP-1F



Type YDP-20F

## ■ Dimensional drawing

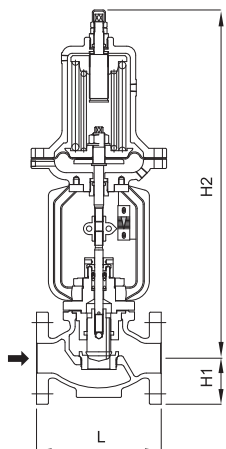

## ■ Features

- As an air-to-close differential pressure valve, it has a structure where the valve opens when the primary pressure goes up. It is installed in between the supply header and return header to control the differential pressure.
- As a self-control type, it does not require auxiliary power supply.
- As a complete balancing type, almost no changes in the set differential pressure resulting from pressure fluctuations.
- Structure is relatively simple, and offers superb durability.
- Convenient piping and handling.
- Separated diaphragm from the main body, not affected by temperature, resulting in outstanding durability.

## ■ Specifications

Type	YDP-1F	YDP-20F
Applicable pressure	Maximum 10 kgf/cm <sup>2</sup> g	Maximum 20 kgf/cm <sup>2</sup> g
Applicable fluid	Cold/hot water	
Fluid temperature	170° C below	
Differential pressure control range	0.05~1.0, 0.5~2.0 / 1.0~3.0, 3.0~5.0	0.5~3.0, 3.0~5.0
Leakage allowance	0.05% less of rated flow	
Direction of installation	Horizontally or vertically	
End connection	KS 10K RF FLANGE	KS 20K RF FLANGE
Materials	Body	GC200
	Disc, Seat	BC6
	Diaphragm	EPDM
Hydraulic test pressure	15 kgf/cm <sup>2</sup> g	30 kgf/cm <sup>2</sup> g

- ▶ Made-to-orders are available for valves with a differential pressure control range of 5 kg/cm<sup>2</sup> or higher.
- ▶ The basic pressure regulating range is 0.5~2.0 kgf/cm<sup>2</sup>.

## ■ Dimensions

Size	L	H1	H2	Cv	Weight(kg)
25(1")	184 (197)	62.5	559	8	24
32(1¼")	180	70	565	12.5	31
40(1½")	222 (235)	80	565	18	33
50(2")	254 (267)	95	586	43	47
65(2½")	276 (292)	115	610	64	51
80(3")	294 (318)	120	630	84	63
100(4")	352 (368)	130	650	152	77
125(5")	400	150	685	200	139
150(6")	451 (473)	180	715	288	168
200(8")	543 (568)	225	755	320	216

- ▶ The length values in parenthesis are for the type YDP-20F.

## ■ Application Diagram (Example)

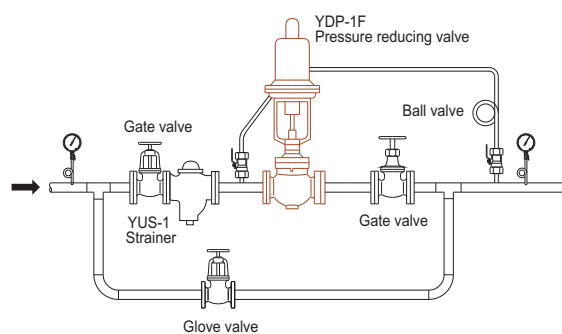

# Type YDP-1F, 20F Differential Pressure Control Valve

## ■ Chart on selecting a size

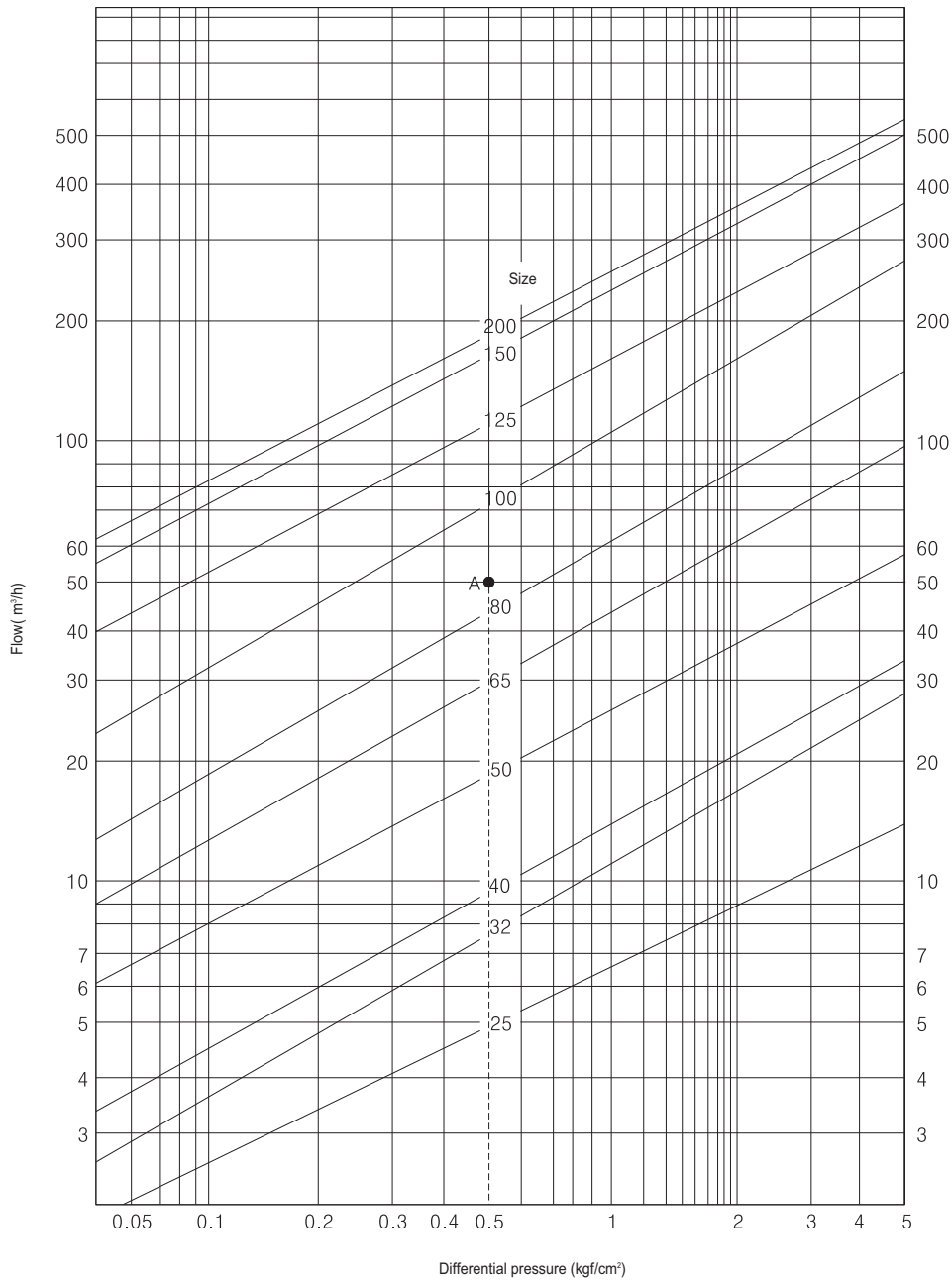

### How to select the size of a valve by the chart

- Example) If the supply side pressure is 4 kgf/cm<sup>2</sup>g, return side pressure is 3.5 kgf/cm<sup>2</sup>g, and maximum capacity is 50 m<sup>3</sup>/h,
- 1) The differential pressure ( $\Delta P$ ) between the supply side ( $P_s$ ) and return side ( $P_r$ ) is 0.5 kgf/cm<sup>2</sup> ( $\Delta P = P_s - P_r$ ).
  - 2) Go up vertically from the differential pressure point (0.5 kgf/cm<sup>2</sup>) to make intersection "A" with the flow (50 m<sup>3</sup>/h).
  - 3) Now that "A" is in between 80 and 100, 100 should be selected.

# Data / Reference

## ■ Types and characteristics of flow control valves

### 1) Balancing valve

The valve's opening percentage is controlled manually, based on which the flow is controlled. As such, there needs to be a graduation to confirm the opening percentage and an embedded linear port for an accurate flow as per the graduation. There also needs to be a locking device that can be used after adjustment.

### 2) Automatic constant flow control valve

Because the valve has an embedded orifice or piston-type linear port, the spring absorbs the differential pressure between the inlet and outlet of the valve, and the opening area of the orifice changes according to the spring's movements. When the differential pressure goes up and thus the flow velocity increases, the valve narrows the opening area. When the differential pressure goes down, it automatically widens the opening area, thereby ensuring that a constant flow is maintained at all times. Because there is no function to readjust the flow, the flow needs to be precisely calculated according to the circuit. If there is a need to change the flow, an internal part (orifice or spring) needs to be replaced.

### 3) Automatic flow control valve

Samyang's automatic flow control valves are diaphragm type valves. They detect load fluctuations that occur in the circuit and ensure that the adjusted flow remains constant at all times. Compared to automatic constant flow control valves, they feature a higher level of precision, more stable control, and a wider applicable differential pressure range. This is why they can be widely used for flow control in apartment buildings and industrial equipment. They also have an embedded linear port, which allows readjustment of the set flow, thereby enabling readjustments on the field. Since they have a cut-off valve function as needed, there is no need for a globe valve on the inlet side of the valve.

### 4) Differential pressure control valve

This type of valve is mostly used for one of two purposes. Installed between the supply header and return header, this valve maintains the system's pressure balance and guarantees the designed operation point of a pump even in case of load changes, thereby ensuring optimal energy distribution efficiency and a certain system life span. The other usage is as a valve for flow control (differential pressure control valve). Installed in the return line of a load device, it maintains a constant flow by maintaining an appropriate differential pressure level of the load device.

## ■ How to order a valve

The following information should be described when consulting or placing an order for a valve.

Model number (type) and standard	
Type of fluid	
Set flow or set flow range (LPM, GPM, m <sup>3</sup> /h)	
Temperature of used fluid (Maximum °C)	
Operating differential pressure range (kg/cm <sup>2</sup> PSI)	
Differential pressure control range (kg/cm <sup>2</sup> PSI)	

▶ For selection of valve, select it to have 30-70% of rated valve capacity.

# Data / Reference

© YFC-2N, 1F, 1S, YTF-20

## ■ Balancing circuit

- If a balancing valve is not used : As seen below, there is a flow imbalance among households.

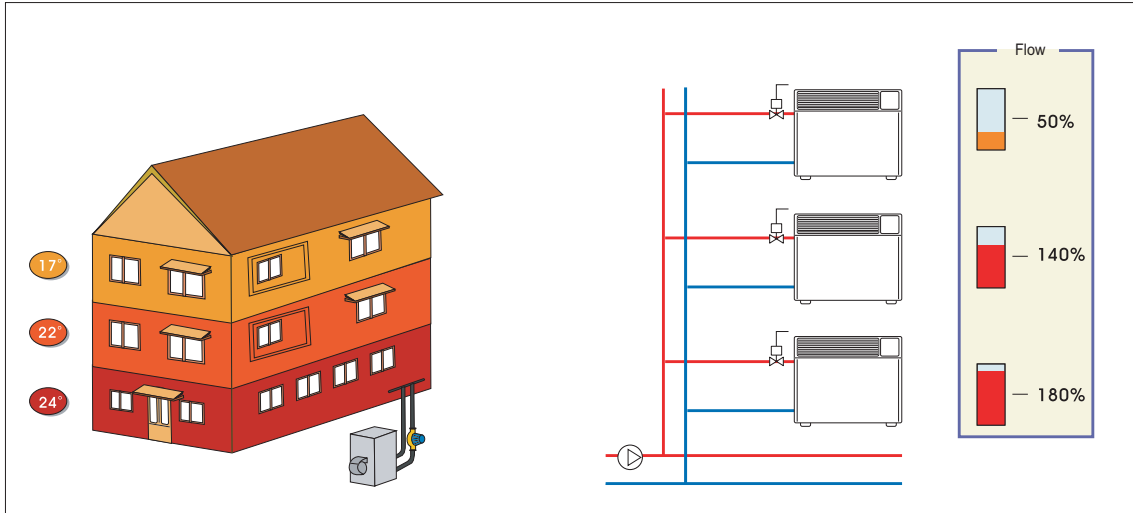

- If a manual balancing valve is used : As seen below, balance is maintained in case of overall usage, but there is an imbalance between the high and low floors when there are load changes.

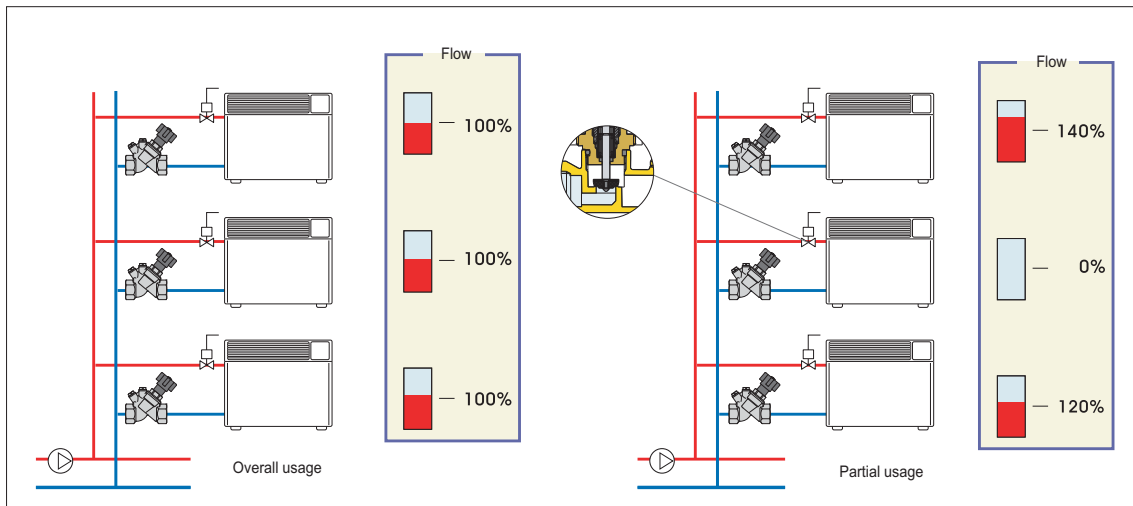

- If an automatic balancing valve is used, a constant flow is maintained in case of overall usage as well as when there are load fluctuations.

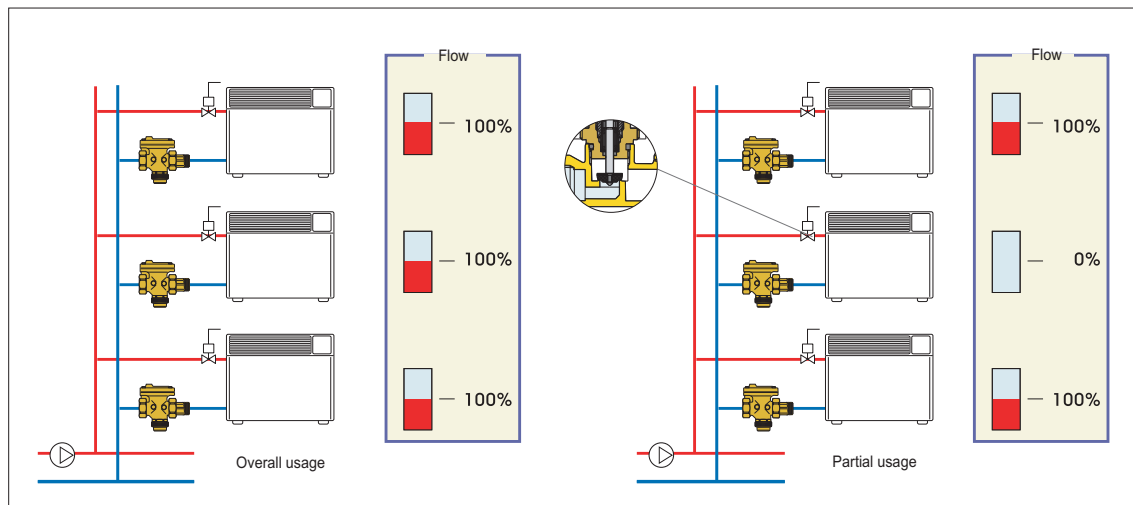

# Data / Reference

## ■ Flow balancing technology for apartments

» Diagram 1

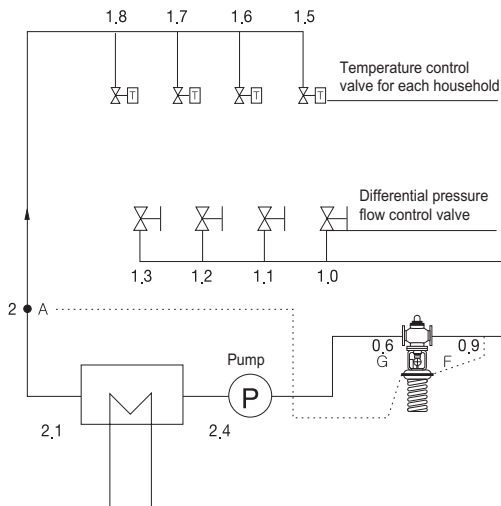

» Diagram 2

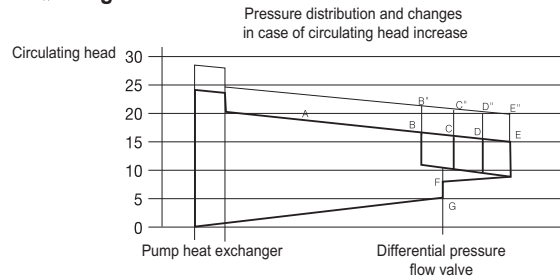

» Diagram 3

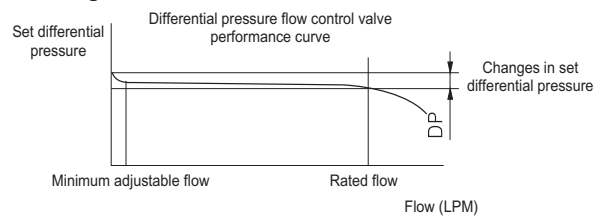

### 1. A system that has a differential pressure flow control valve installed

1. A system that has a differential pressure flow control valve installed

The pump lift is 24 m,

Flow is 400 LPM,

Pressure loss of heat exchanger is 0.3 bar,

Pressure loss of the differential pressure flow control valve is 0.3 bar, and

The set differential pressure is operating as the differential pressure between points A and F ( $2.0 - 0.9 = 1.1$  bar);

This is a case where a flow of 100 LPM has been distributed to each standing line. If the flow is cut off due to the operation of temperature control valves installed at points B, C, D, and E according to changes in outside temperature, the lift of point A rises, resulting in higher pressure. The differential pressure flow control valve detects the increased lift of point A and increases point F to the same level, thereby maintaining a differential pressure of 1.1 bar between points A and F. The pressure gradient of the entire pipeline becomes constant (refer to Diagram 2), resulting in optimal flow balancing effects despite the variable flow.

Also, a constant differential pressure is maintained at all times even in cases where only one or two apartment units require heating, thereby preventing the breakdown of the temperature control valve for each household and completely resolving noise-related problems within households.

### 2. A system that has a constant flow control valve (automatic balancing valve) installed

In Diagrams 4 and 5, a constant flow control valve (automatic balancing valve) is installed in the same location. If the flow becomes smaller after operation of temperature control valves at points B, C, D, and E, the constant flow control valve will operate below the control range since the flow will be smaller than the original flow of 400 LPM. As such, the pressure gradient within the pipeline will change, leading to a flow imbalance.

There will be excessive flow in certain sections. This is why some adopt the solution of installing a constant flow control valve for each standing line, but this leads to the issue of imbalance among households within each standing line. This is why it is recommended that a constant flow control valve should be installed for each household. However, in case of continuous heating, where the pump needs to be operated even when the level of used flow is extremely low, the lift of the circulation pump rapidly increases. As such, there is noise since the differential pressure goes up when the constant flow control valve is operated. Moreover, rapid fluctuations in differential pressure lead to decreased control performance of each household's temperature control valve and even cause breakdown. This is why there is a need to install a differential pressure valve or differential pressure flow control valve and appropriately maintain a differential pressure of the supply and return to ensure definite balancing effects.

» Diagram 4

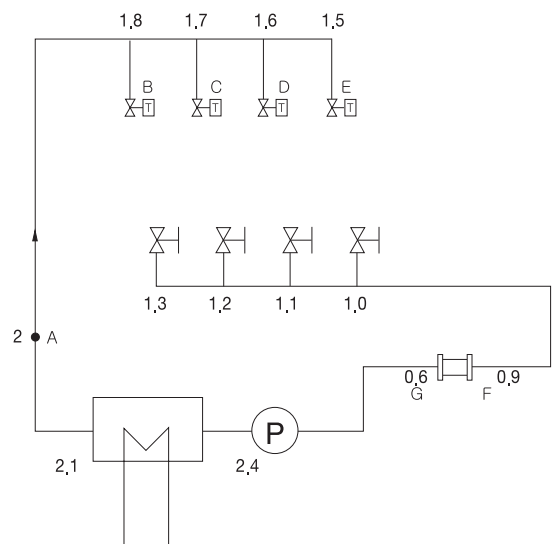

» Diagram 5

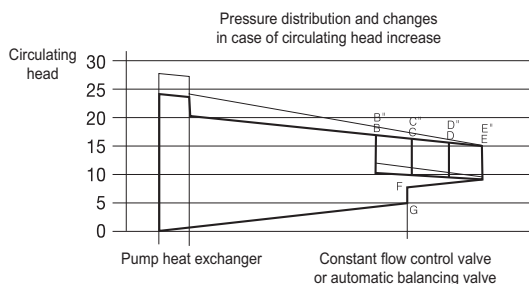

» Diagram 6

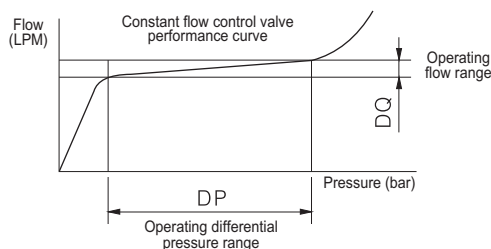

» Diagram 7

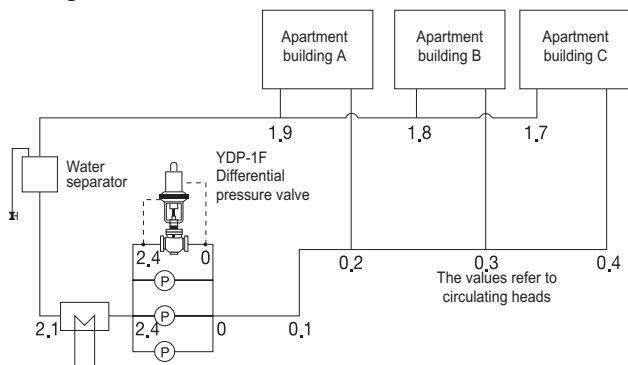

» Diagram 8

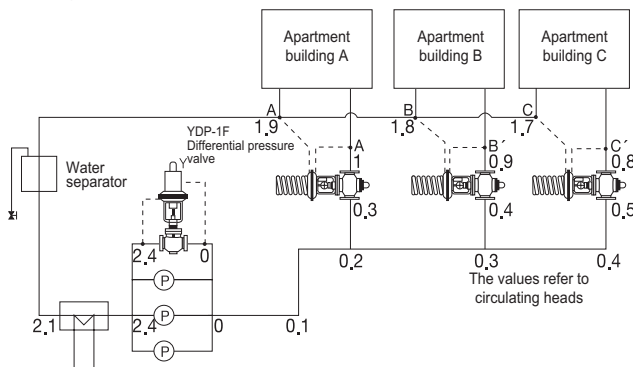

» Diagram 9

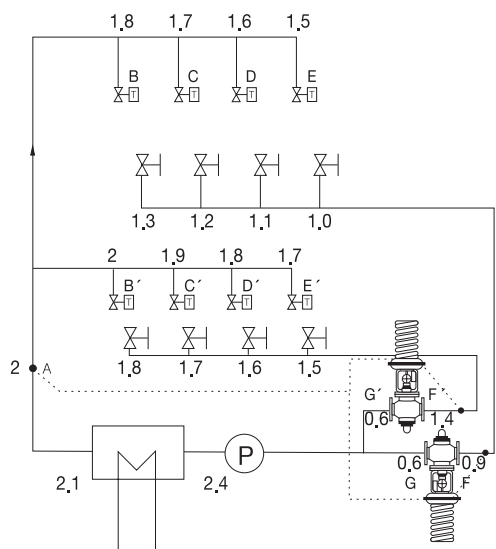

### 3. System flow control using differential pressure valve

As shown in Diagram 7, the method of balancing the flow with only a differential pressure valve of the machinery room is adopted for small systems, and is mostly used for single pump systems that do not have a high circulating head. The capacity is 80% or more of the pump flow. The set differential pressure is the same as the pump lift, or as the pressure loss value of the overall circulation pipelines if there is an overall pressure loss value.

### 4. Systems using a differential pressure valve and a differential pressure flow control valve

A system that uses only a differential pressure valve is difficult to apply when several pumps are operated or load fluctuations are substantial. In this case, there is a need to install a differential pressure valve for pump relief purposes and set up a differential pressure flow control valve for each apartment building. This would enable to establish balance among apartment buildings as well as among different zones within an apartment building through a differential pressure flow control valve.

#### <Valve selection>

##### (1) Differential pressure valve

As a relief purpose, it determines the relief flow which is over 25 % of a pump flow since it could be selected within the scope where the pump would not get excessive loads. The set differential pressure would be the same as the pump lift or the pressure loss value of the overall circulation pipelines.

e.g.) Pump flow  $Q_p=75\text{ton/h}$

Pump lift  $H=24\text{m}=2.4\text{bar}$

Relief flow (usually, 30~35% of pump flow)  $Q_r=22.5\text{T/H}$

$$C_v = \frac{1.167 \times Q_r}{\sqrt{\Delta P}} = \frac{1.167 \times 22.5}{\sqrt{2.4}} = 16.95$$

Select the valve  $C_v$  value as YDF-1F 40A( $C_v=18$ ) which is over 16.95

##### (2) Differential pressure flow control valve

Since the valve controls the flow changes occurring due to the temperature control valve operation within an apartment, if the flow of each apartment would be 25ton/h,

$Q = 25\text{ton/h}(417\text{LPM})$

$$C_v = \frac{1.167 \times Q_r}{\sqrt{\Delta P}} = \frac{1.167 \times 25}{\sqrt{0.3}} = 53.26$$

( $\Delta P$ : Here, 0.3. It is the maximum pressure loss of the valve itself and constant)

Select the valve  $C_v$  value as YDF-2F 65A( $C_v=58$ ) which is larger than 53.2. At this time, the controlling differential pressure  $DP$ s such as the points A-A', B-B', and C-C' which the differential pressure flow control valve should control are irrelevant to the valve size selection and are different a bit according to working places. When the required flow for each apartment is very huge, the differential pressure flow control valve should be enlarged. So, if the range ability would be 1/40, 1/40 of the maximum flow could not be controlled, in this case, it would be appropriate to install the differential pressure flow control valve for each zone like Picture 7.

Schematic diagram of the intermediary machinery room of a district heating system's primary pipeline

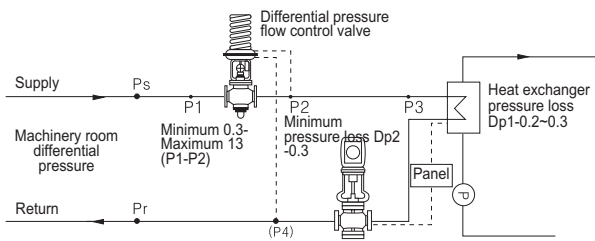

Machinery room pressure drop curve

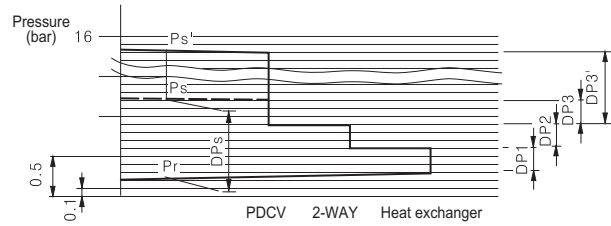

Overall pressure distribution chart for district heating pipelines

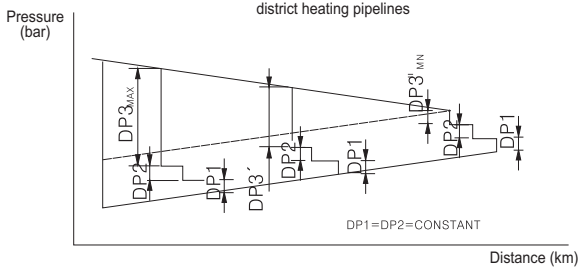

the  $\Delta P$

## ■ Valve selection for an intermediate machinery room for district heating

### <Terminologies>

- Ps : Pressure of high-temperature water that is supplied to the machinery room (different for each district)
- Pr : Pressure returning to the power plant (from the machinery room)
- P4 = Pr, Ps = P1
- DP1 : Pressure drop in heat exchanger
- DP2 : Pressure drop in 2-way valve
- DP3 : Pressure drop in differential pressure flow control valve (Minimum 0.3 ~ Maximum 13 bar)

The pressure distribution in Diagram 12 indicates that DP<sub>1</sub> and DP<sub>2</sub> are constant. This is why DP<sub>3</sub> the pressure drop in the differential pressure flow control valve is extremely high at the maximum level (approximately 13 bar) in the case of a machinery room located near the power plant. The Ps' in Diagram 11 changes in-between Ps and Ps' according to outdoor air temperature, and the maximum pressure loss (minimum differential pressure) of the differential pressure flow control valve is 0.3. As such, the pressure drop in the machinery room located the farthest away is approximately DP<sub>1</sub>+DP<sub>2</sub>+DP<sub>3min</sub>+line loss=1 bar. (Diagram 12)

### 1) 2-way valve selection

The 2-way valve always operates within a  $\Delta P$  that is between 0.3 and 0.8 bar based on the differential pressure flow control valve, but its control performance is affected by the differential pressure flow control valve performance. The  $\Delta P$  maintaining capability of the differential pressure flow control valve is determined by set differential pressure changes (DP) from the minimum controllable flow to the maximum flow. Higher performance differential pressure flow control valves have lower DPs, which means better control performance of the 2-way valve. If -2F, 20F, etc. are installed on PDCV Y, there is no operational problem even if the maximum allowable differential pressure of the 2-way valve is at least 1 bar. (3.5 bar is the practical standard of the Korea District Heating Corp.)

#### Calculation example>

Ps=P<sub>1</sub> : 15bar  
 Pr=P<sub>4</sub> : 4bar  
 Q=20ton/h(Flow calculated based on the connected thermal load)  
 The following is a calculation of the required Cv value,

$$Cv = \frac{1.167 \times Q}{\sqrt{DP_3}} = \frac{1.167 \times 20}{\sqrt{0.7}} = 27.89$$

(DP<sub>2</sub>=2-way valve pressure loss)

A valve whose Cv is bigger than 27.89 needs to be chosen. A safety coefficient of 0.7 is usually applied as a divider.

### 2) Differential pressure flow control valve selection

The differential pressure flow control valve performs the role of maintaining the pressure between P<sub>2</sub> and P<sub>4</sub> within 0.6 to 0.8 bar, and thus the set differential pressure is adjusted to 0.6 to 0.8 bar. However, the valve capacity should be chosen based on 0.7 bar pursuant to the usage facility standards of the Korea District Heating Corp. However, the P<sub>3</sub> - pressure drop in the differential pressure flow control valve - in machinery rooms varies from 0.3 to 13 bar. This is why the valve size becomes different for the same thermal load. However, the pressure drop in the differential pressure flow control valve frequently changes according to fluctuations in outdoor air temperature, making it difficult to obtain the exact value even for a specific machinery room. This is why DP<sub>3</sub>=0.7 bar is used for calculation. Based on the example above:

$$Cv = \frac{1.167 \times Q}{\sqrt{DP_3}} = \frac{1.167 \times 20}{\sqrt{0.7}} = 27.89$$

A selection should be made on a valve whose Cv value is bigger than 27.89. A safety coefficient of 0.7 is sometimes applied as a divider in consideration of control valve characteristics, depending on the load type of the system.

# Data / Reference

## Terminology

- Set pressure (Set differential pressure): Pressure on the inlet side (pressure difference between the valve's inlet and outlet) when the fluid begins to flow, resulting from operation of the primary pressure control valve and differential pressure control valve.
- Static pressure (Static differential pressure): Pressure on the inlet side (pressure difference between the valve's inlet and outlet) when the fluid's flow comes to a stop, resulting from closing of the primary pressure control valve and differential pressure control valve.
- Differential pressure: Pressure of difference between the set pressure (set differential pressure) and static pressure (static differential pressure)
- Accumulation: Indicating, in percentage or unit pressure, the level of pressure that is above the set pressure (set differential pressure) so as to calculate the discharge requirement
- Capacity-determining pressure (Capacity-determining differential pressure): As a base pressure that determines the rated capacity, this is the pressure at the inlet side when the flow continues after the pressure reaches the nominal pressure level that equals or is above the set pressure (set differential pressure)
- Rated discharge capacity: Maximum capacity that can be guaranteed in terms of the capacity-determining pressure (capacity-determining differential pressure)

※ Notes : Information in the parenthesis applies to the differential pressure control valve.

## Selecting a size of a primary pressure control valve

- ① The size selection chart should be used to select a size.
- ② If the primary pressure and back pressure are not constant and used within a certain range, select a size based on the back pressure or primary pressure when the difference is at its lowest level.
- ③ If used as a pump relief valve, the discharge capacity of the primary pressure control valve is determined as follows: In case of a complete cut-off state on the pump's discharge side, determine discharge volume "b" of lift "a" that is equivalent to the control pressure, based on the pump characteristics curve. The "b" becomes the discharge capacity of the primary pressure control valve. If it is not a complete cut-off state on the discharge side, and assuming that the minimum flow used at all times is "c," then b-c becomes the discharge capacity of the primary pressure control valve.

## Pressure and flow characteristics curve

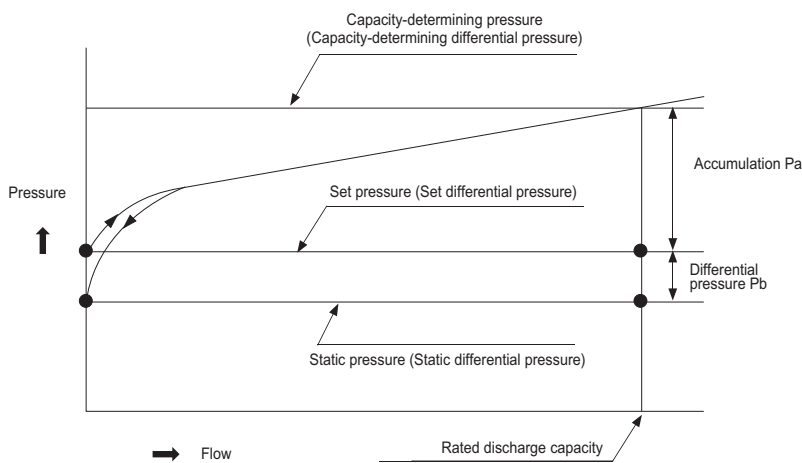

## Pump characteristics curve

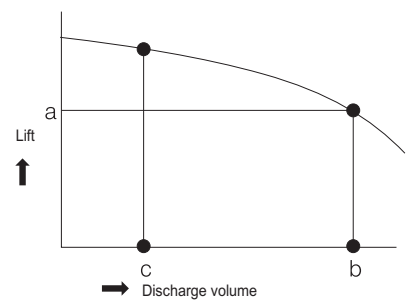

## Characteristics

Type	Accumulation Pa	Differential pressure Pb
Primary pressure control valve	Within maximum value of the regulating spring range X 15%. Within 20% in case of a 5 kgf/cm <sup>2</sup> g spring with a size of at least 100.	Within set pressure X 10% (minimum value of 0.2 (kgf/cm <sup>2</sup> ))
Differential pressure control valve		Within set differential pressure X 10% (minimum value of 0.2 (kgf/cm <sup>2</sup> ))

# Data / Reference

## ■ How to adjust the differential pressure flow

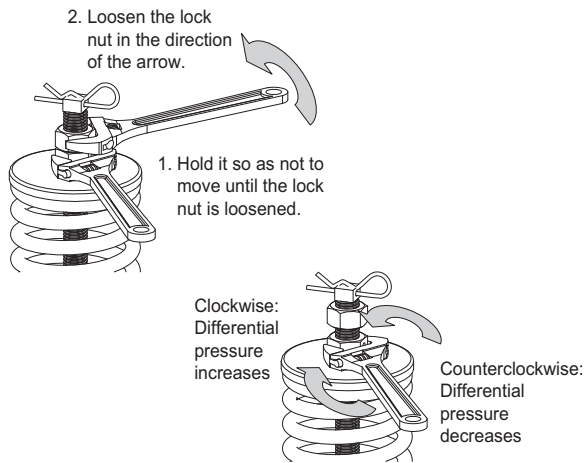

## ■ How to adjust the differential pressure

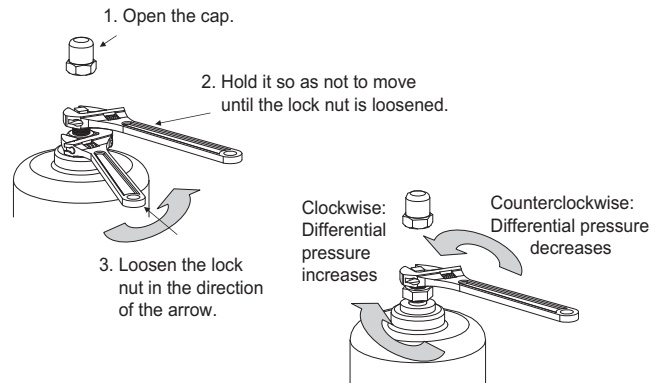

※ If not requested otherwise, the differential pressure is set to 0.7 kgf/cm<sup>2</sup> prior to product delivery.

## ● Cautions when handling the product

The following should be noted when handling the product so that it can be operated at maximum performance.

1. Do not cause impact on the product.
2. Avoid storage in humid and dusty places.
3. Pay special attention to prevent entry of foreign substances into the product.
4. When installing the product in a pipeline, completely remove scales, sand, dregs, etc. and clean the area that comes into contact with the gasket.
5. If possible, install the product where easy repair and inspections can take place.

※ The product's structure, dimensions, materials, etc. are subject to change without notice to improve its performance.

## ● Maintenance

### » Leakage at the packing of stuffing nut boxes

1. Close after checking the gate valve. -Close the main valve.
2. Close the ball valve of the pressure-inducing pipeline.
3. Slowly loosen after checking the set spring height.
4. Detach the pressure-inducing pipeline.
5. Loosen after checking the set height of the stem screw of the indicator.
6. Slowly loosen the stuffing nut box. - Stop disassembling if water continuously flows out.
7. Check and change the packing, and assemble in reverse order.

### » O-ring leakage

1. Close after checking the gate valve.
2. Close the ball valve of the pressure-inducing pipeline.
3. Slowly loosen after checking the set spring height.
4. Detach the pressure-inducing pipeline.
5. Loosen after checking the set height of the stem screw of the indicator.
6. Disassemble the actuator.
7. Polish the stem with soft sandpaper if extremely rusty.
8. Replace the o-ring, and assemble.

※ Checking for diaphragm function :  
The spindle is regarded as being damaged if it does not operate when draining water with a supply air pin in a state where the supply's ball valve is closed and the return's ball valve is open.



# Level Control Valve

# 5

## Level Control Valve



Developed based on extensive experience, the water level control valves ensure easy maintenance, offer good durability, and prevent water hammers. They feature an outstanding performance and a wide array of functions that satisfy user needs.

### Level control valve

Type	Size	Applicable pressure (kgf/cm <sup>2</sup> g)	Materials		End connection	Page
			Body	Disc, seat		
YAW-3S	32(1¼")~40(1½")	Max. 10	GC200	NBR, BC	KS PT SCREW	104
YAW-3F	50(2")~150(6")				KS 10K RF FLANGE	
YAWEL-1	100(4")~350(14")				107	

# Type YAW-3S, 3F Level Control Valve

The type YAW-3S and 3F water level control valves were developed for the exclusive purpose of controlling the water level of a wide array of water tanks. They are optimal water level control valves that have a simple structure and are small sized and lightweight, thereby ensuring easy handling and installation.



Type YAW-3S



Type YAW-3F

## ■ Features

- Embedded strainer prevents various foreign substances into the pipeline.
- No external pipeline, kept warm easily & no concerns of freezing damage.
- Large capacity make suitable for apartment water & elevated tanks.
- EM mark acquired.

## ■ Specifications

Type	YAW-3S	YAW-3F
Size	32A~40A	50A~150A
Applicable pressure	Maximum 10 kgf/cm <sup>2</sup> g	
Minimum differential pressure in the inlet and outlet side of the valve	0.35kgf/cm <sup>2</sup>	
Fluid temperature	5~80° C	
Function	On and off operation by a pilot solenoid valve	
Solenoid valve	AC 220V, 60Hz	
Applicable fluid	Drinking water, fresh water, industrial water, agricultural water	
End connection	KS PT SCREW	KS 10K RF FLANGE
Materials	Body	GC200
	Disc, seat	NBR, BC
Hydraulic test pressure	15 kgf/cm <sup>2</sup> g	

## ■ Dimensions

(mm)

Size	L	H1	H2	Cv	Weight(kg)	Notes
32A(1¼")	248	43	135	30	14	Screwed type
40A(1½")	248	43	135	35	15	
50A(2")	248	77.5	135	40	17	Flanged type
65A(2½")	270	87.5	138	62	22	
80A(3")	270	92.5	138	90	22	
100A(4")	288	105	148	140	27	
125A(5")	400	125	225	220	60	
150A(6")	400	140	225	315	69	

## ■ Dimensional drawing

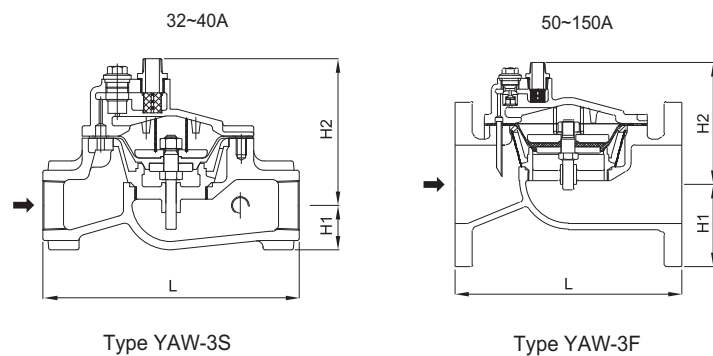

# Type YAW-3S, 3F Level Control Valve

## ■ Chart on selecting a size

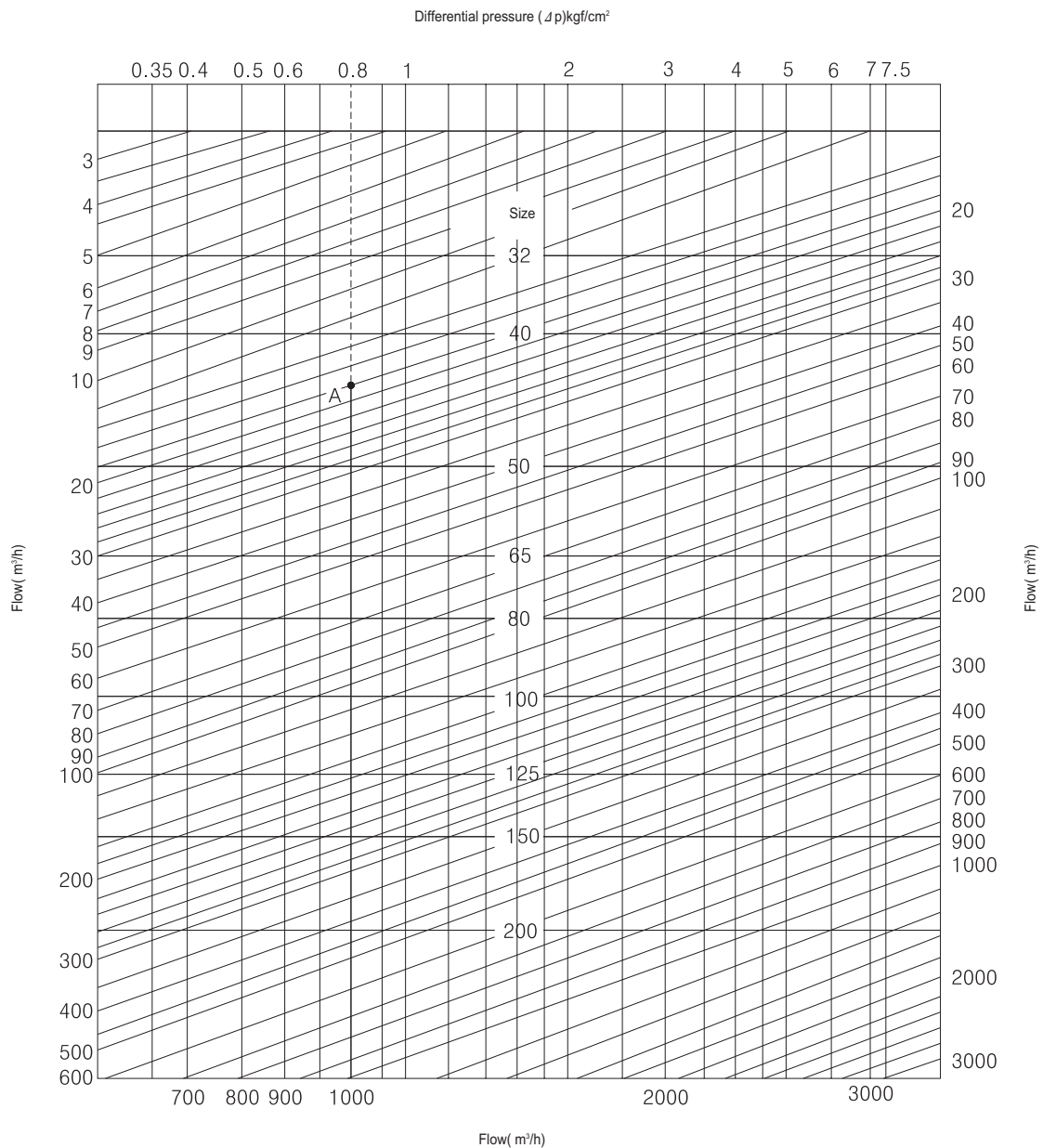

### How to select the size of a valve by the chart

Example) If the supply pressure is 3 kg/cm<sup>2</sup>g,  
 Back pressure is 2.2 kgf/cm<sup>2</sup>g,  
 Flow is 18 m<sup>3</sup>/h,

Then the differential pressure is 0.8 kgf/cm<sup>2</sup>g. Since  $\Delta P$  is at the point of intersection between the line of 0.8 kgf/cm<sup>2</sup>g and a flow of 18 m<sup>3</sup>/h, the valve's size should be selected as 50 in order to avoid harmful stress on the pipeline.

# Type YAW-3S, 3F Level Control Valve

## ◎ Standard Pipeline Installation of the Types YAW-3S and 3F Level Control Valves

### ■ Application Diagram (Example)

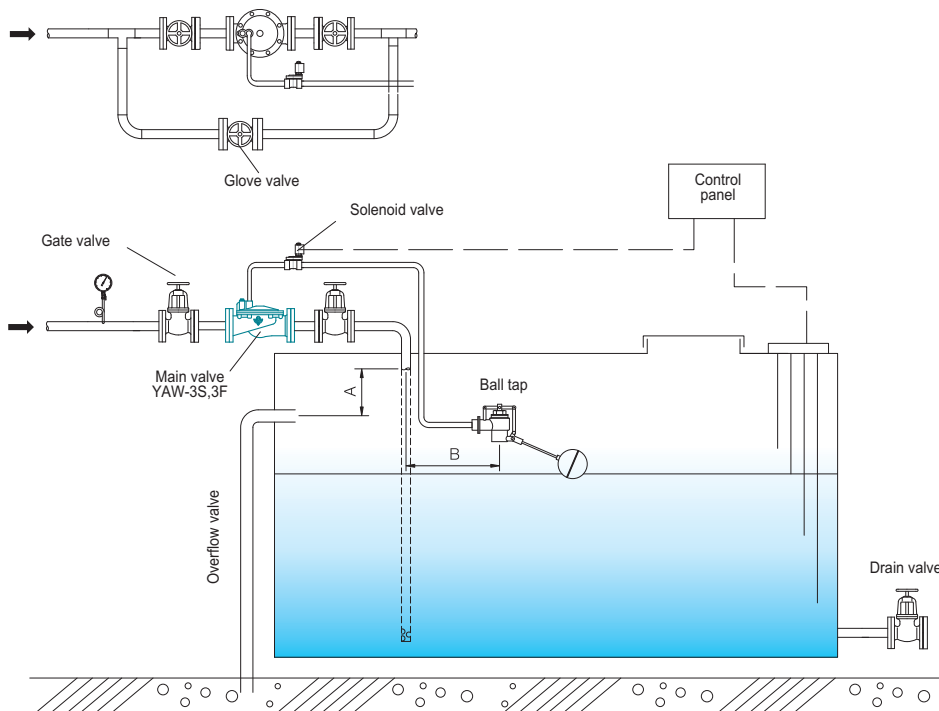

### ■ Cautions for pipeline installation

1. A bypass pipeline must be installed.
2. In case of installation in an underground water tank, install a pump or sufficiently pump out water to prevent damages caused by water overflow.
3. The distance of "A" should be at least 1.5 times (minimum 50 mm) the pipe diameter.
4. In case of installation of a ball tap, make the distance of "B" as long as possible (minimum 1 m) to prevent damage to the ball tap resulting from irregular water waves. The ball tap should be installed in close proximity to a manhole for easy repair and inspections.
5. The overflow pipeline should be connected to an underground drainage system. (Prevents damage caused by overflow.)
6. In terms of the end connection between the valve's body and ball tap, a union should be used to ensure easy disassembly and inspection.

### ■ Cautions for operation

1. Between installation and operation, completely remove foreign substances within the pipeline by blowing them out through the bypass pipeline.
2. If the main valve is not operating due to a power failure or breakdown of the ball tap, use the valve by opening the ball valve and consult Samyang technicians for further instructions. (The ball valve should be closed unless there is an emergency situation.)

➤ Diagram 2. Solenoid valve connecting circuit

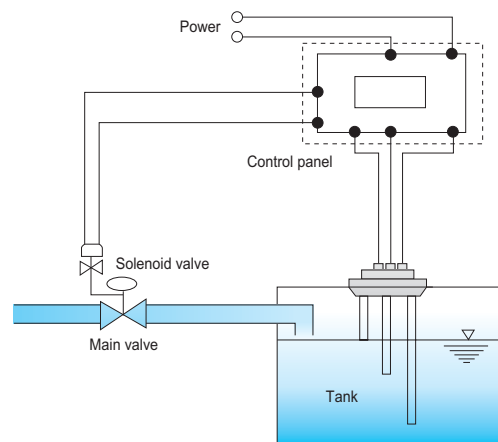

# Type YAWEL-1 Level Control Valve

The type YAWEL-1 is a large-capacity level control valve that supplies water by opening when the water level inside a water tank goes down to the level at which water supply is commenced. The valve closes when the water level rises to the level at which water supply is stopped. The valve thus features an outstanding performance in controlling the water level.



## ■ Features

- Automatically opened & closed, without external power supply even large-diameter.
- No leakage with special rubber diaphragm & disc.
- Attached speed control valve (needle valve) can adjust main valve's opening & closing speed.
- Ensure easy repair & inspections structure.

## ■ Specifications

Applicable fluid		Fresh water, industrial water, agricultural water
Function		On and off operation by a pilot solenoid valve
Applicable pressure		Maximum 10 kgf/cm <sup>2</sup>
Minimum differential pressure in the inlet and outlet side of the valve		0.5kgf/cm <sup>2</sup>
Fluid temperature		5~80° C
Solenoid valve	Standard	50~150A : 1/2", 200~350A : 1"
	Power	AC200V, 60Hz
End connection		KS 10K RF FLANGE
Materials	Body	GC200
	Disc, seat	NBR, BC
	Diaphragm	NBR
Hydraulic test pressure		15 kgf/cm <sup>2</sup>

## ■ Dimensions

Size	L	H1	H2	Cv	Weight(kg)
100(4")	400	120	209	160	67.5
150(6")	520	170	237	360	123
200(8")	640	210	390	640	205
250(10")	740	250	481	1000	440
300(12")	900	290	557	1440	516

▶ Made-to-orders are available for valves with a size of 350 or larger.

## ■ Example of application

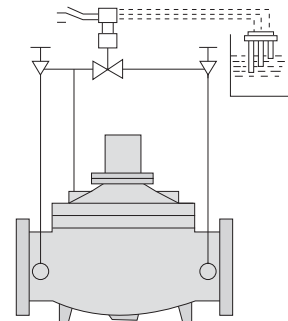
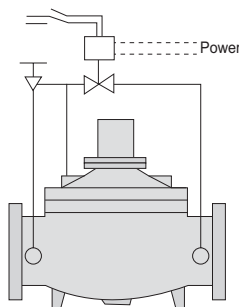

## ■ Dimensional drawing

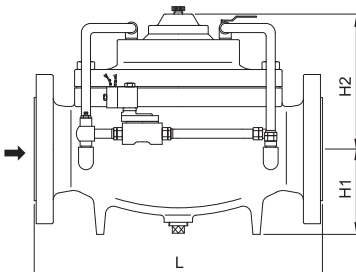

### 1) Automatic control and remote operation

Because it has adopted a balance structure, even a large-diameter valve can be opened and closed with simple power switching operation. It can also offer a remote control function if applied with appropriate wiring.

### 2) Level control function

The valve can be used to maintain a constant water level for water tanks, settling tanks, pressure control tanks, and swimming pools.



# Type YAWEL-1 Level Control Valve

## ■ Chart on selecting a size

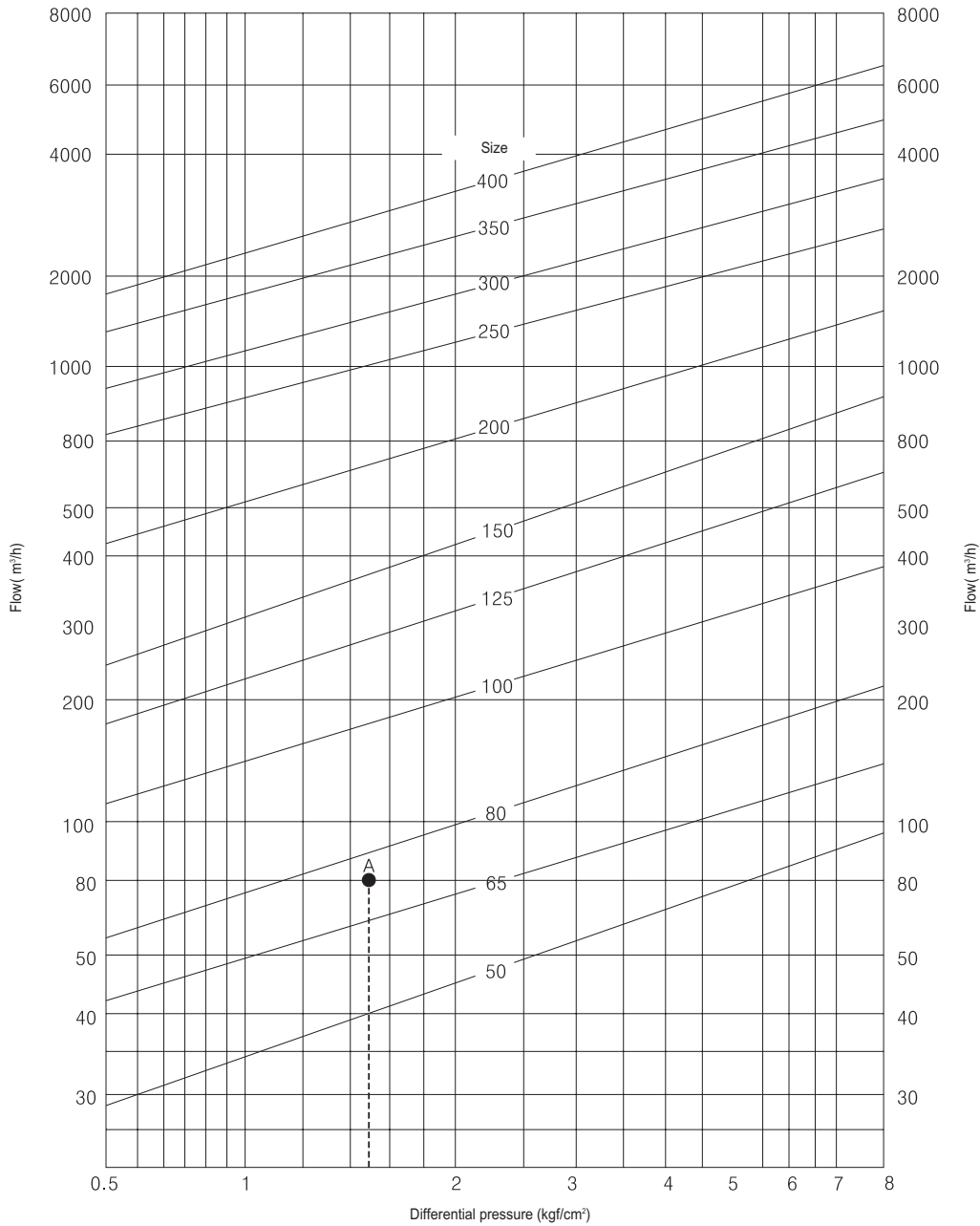

### How to select the size of a valve by the chart

Example) If the primary pressure is 1.5 kg/cm<sup>2</sup>g, secondary pressure is 0 kg/cm<sup>2</sup>g, and flow is 80 m<sup>3</sup>/h, the differential pressure  $\Delta P$  is 1.5-0=1.5 (kg/cm<sup>2</sup>g) since the primary pressure is 1.5 kg/cm<sup>2</sup>g and secondary pressure is 0 kg/cm<sup>2</sup>g. Determine "A," the point of intersection between the differential pressure (1.5 kg/cm<sup>2</sup>g) and flow (80 m<sup>3</sup>/h). Now that point A is in between a size of 65 and 80, a diameter of 80 should be selected in order to avoid harmful stress on the pipeline.

# Type YAWEL-1 Level Control Valve

## ■ How the valve works

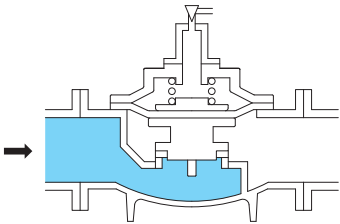
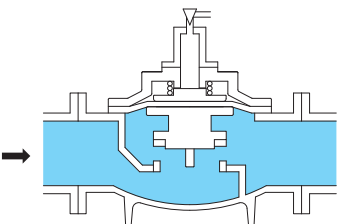
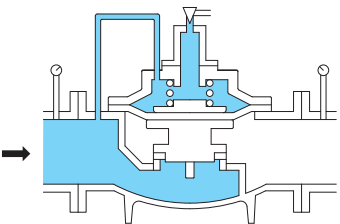
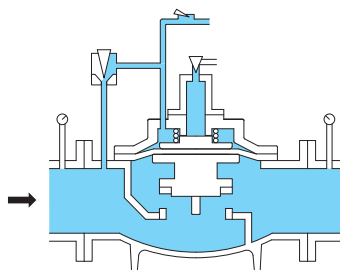
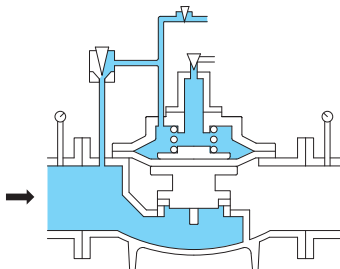
	<p>1. At first, the valve is ...</p> <p>The level control valve consists of a main valve and an auxiliary valve. As shown in the diagram, the valve remains closed, by the main valve's weight and the spring's force, when the fluid is not flowing.</p>
	<p>2. When the fluid flows ...</p> <p>When the level control valve receives pressure, the main valve disc, which was closed, is slightly raised, resulting in the fluid passing through the inside of the valve. In other words, the pressure of the discharged fluid operates in the lower part of the diaphragm and completely opens the main valve.</p>
	<p>3. When pressure is applied to the upper part of the diaphragm ...</p> <p>Once the fluid enters the upper part of the diaphragm through the copper tube that connects the inlet of the level control valve with the upper part of the diaphragm, the pressure level of the upper part and lower part of the diaphragm becomes the same. The main valve begins to close as balance is reached between the main valve's weight and the spring's force. In other words, the valve closes when pressure reaches the upper part of the diaphragm, and opens as the pressure disappears.</p>
	<p>4. When the valve begins to open ...</p> <p>Install a speed control valve in the middle of the copper tube so that one side of the copper tube is installed to two directions. If the speed control valve is adjusted so that the volume of fluid discharged from the discharge valve is larger than the volume of fluid that passed through the speed control valve, the discharge valve remains open. Then the pressure of the upper part of diaphragm goes down and the main valve opens.</p>
	<p>5. Whether it can be automatically opened and closed ...</p> <p>Once the discharge valve is closed, pressure accumulates in the upper part of the diaphragm and the main valve closes. When the discharge valve is opened by adjusting it slightly, the force applied to the top and the bottom of the diaphragm reach a balance, and the opening of the main valve is automatically controlled.</p>



# Type YAWEL-1 Level Control Valve

## ◎ Standard Pipeline Installation of the Type YAWEL-1 Level Control Valve

### ■ Application Diagram (Example)

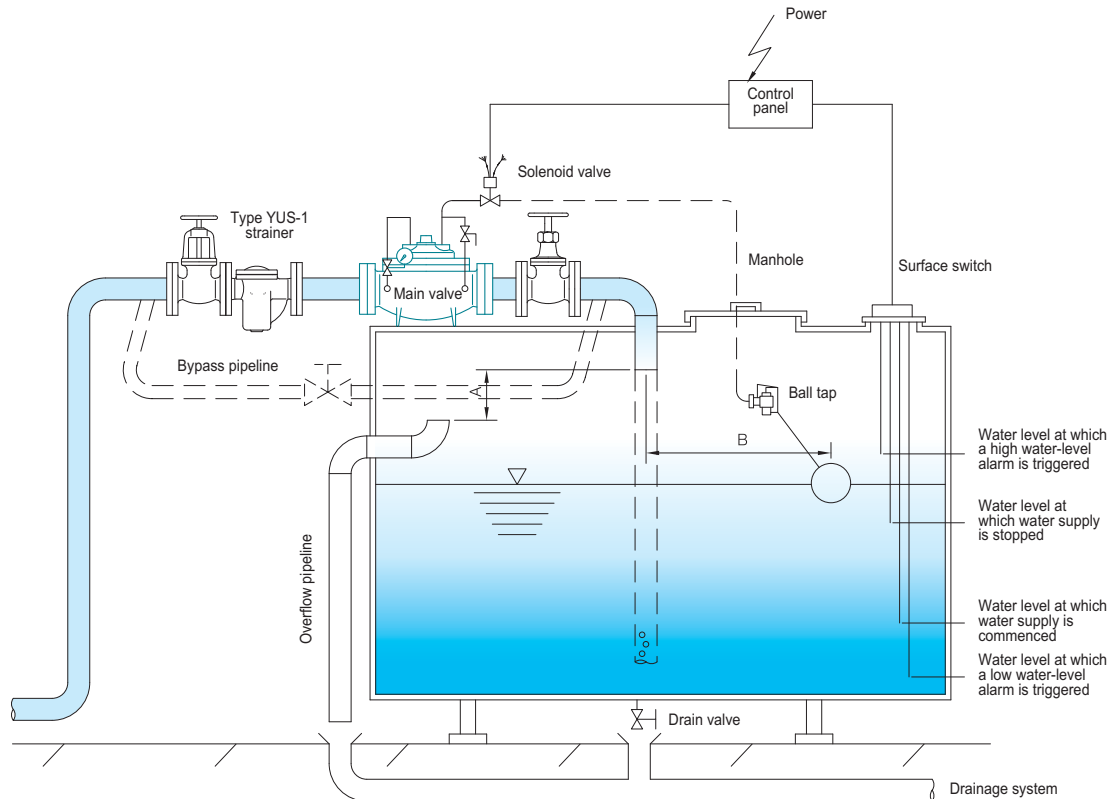

### ■ Cautions for pipeline installation

1. A bypass pipeline must be installed.
2. A strainer should be installed on the inlet side of the main valve to prevent the breakdown of the valve resulting from foreign substances.
3. The distance of "A" should be at least 1.5 times (minimum 50 mm) the pipe diameter.
4. In case of installation of a ball tap, make the distance of "B" as long as possible (minimum 1 m) to prevent damage to the ball tap resulting from irregular water waves. The ball tap should be installed in close proximity to a manhole for easy repair and inspections.
5. The overflow pipeline should be connected to an underground drainage system. (Prevents damage caused by overflow.)
6. In terms of the end connection between the valve's body and ball tap, a union should be used to ensure easy disassembly and inspection.
7. The ball tap should be installed at a level lower than the overflow pipeline and higher than the water level at which the high water-level alarm is triggered.
8. Consult with Samyang if there is a need to install the level control valve below the water level within the tank.

➤ Diagram 2. Solenoid valve connecting circuit

### ■ Cautions for operation

1. Between installation and operation, completely remove foreign substances within the pipeline by blowing them out through the bypass pipeline.
2. Since the needle valve ② was attached to adjust the opening and closing speed of the main valve, use it to adjust the opening and closing speed when there is a water hammer or pipeline vibration during operation.
3. If the main valve is not operating due to a power failure or breakdown of the ball tap, open and use the ball valve ① and consult Samyang technicians for further instructions. (The ball valve ① should be closed unless there is an emergency situation.)

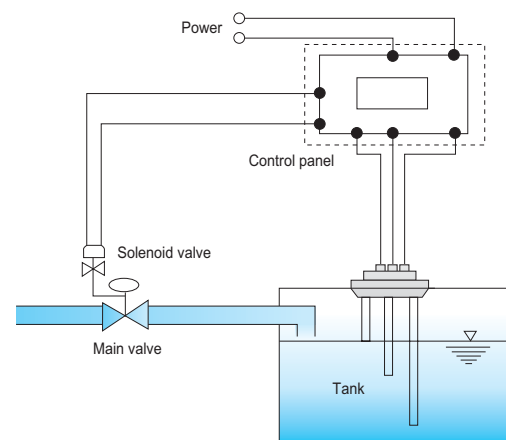

# Strainer / Water Separator

# 6

## Strainer / Water Separator



### Strainers

Type	Size	Applicable pressure(kgf/cm <sup>2</sup> g)	Body materials	End connection	Page
YKY-1	15(1/2")~50(2")	Maximum 10	GC200	KS PT SCREW	112
YKY-2	15(1/2")~50(2")			KS 10K FF FLANGE	
YKY-11	15(1/2")~50(2")		GC	KS PT SCREW	113
YKY-12	65(2 1/2")~200(8")			KS 10K FF FLANGE	
YKY-3	15(1/2")~500(20")	Maximum 20	GCD450, SCPH2	KS 20K RF FLANGE	114
YKY-5B	32(1/2")~50(2")	Maximum 10	BC6	KS PT SCREW	115
YKY-6	15(1/2")~25(1")	Maximum 10	BsC1		
YBS-6	20(3/4")~25(1")	Maximum 10	GC200		
YUS-1	20(3/4")~300(12")			116	
① - Strainer	50(2")~300(12")			117	

### Separators

Type	Size	Applicable pressure(kgf/cm <sup>2</sup> g)	Body materials	End connection	Page
YSS-100	15(1/2")~50(2")	Maximum 20	SPPS	KS PT SCREW	118
	15(1/2")~250(10")			KS 20K RF FLANGE	
YSS-511S	20(3/4")~25(1")	Maximum 10	Brass	KS PT SCREW	119
YSS-511F	50(2")~150(6")		Epoxy-coated steel	KS 10K RF FLANGE	

# Type YKY-1, 2 Strainer

These are Y-type strainers of cast iron screw and flange type. They are compact and have a large filtering area, and thus are optimal strainers for an automatic valve line.

6



Type YKY-1



Type YKY-2

## ■ Specifications

Type		YKY-1	YKY-2
Applicable fluid		Steam, liquid, vapor	
Applicable pressure		Maximum 10 kgf/cm <sup>2</sup> g	
Fluid temperature		220° C below	
End connection		KS PT SCREW	KS 10K FF FLANGE
Materials	Body	GC200	
	Cover	C3771	GC200
	Screen	STS	
Hydraulic test pressure		20 kgf/cm <sup>2</sup> g	

- ▶ As wire screen, product which would embed max. 200MESH could be produced upon request.
- ▶ In terms of flanges, the designated diameter of 20-50A are using RF Type, of 65~200A are using FF Type, and of over 250A are using RF type.

## ■ Dimensions

### » Type YKY-1

Size	L	H	Weight(kg)
15(1/2")	80	60	0.5
20(3/4")	95	69	0.7
25(1")	110	84	1.2
32(1 1/4")	135	105	2.0
40(1 1/2")	160	123	3.4
50(2")	185	134	5.0

### » Type YKY-2

Size	L	H	d	Weight(kg)
20(3/4")	132	69	-	0.6
25(1")	153	84	3/8"	1.3
32(1 1/4")	182	105	3/8"	2.1
40(1 1/2")	207	123	3/8"	7.3
50(2")	230	142	3/8"	8.9
65(2 1/2")	285	163	1/2"	12.2
80(3")	305	195	1/2"	17.1
100(4")	355	265	1/2"	24.2
125(5")	405	308	3/4"	36.2
150(6")	464	368	3/4"	53.2
200(8")	550	484	1"	81.6
250(10")	684	560	1"	165.2
300(12")	848	792	1"	288.2
350(14")	1040	848	1"	488.2
400(16")	1040	890	1"	500.2
450(18")	1082	960	1"	800.2

## ■ Pressure loss curve

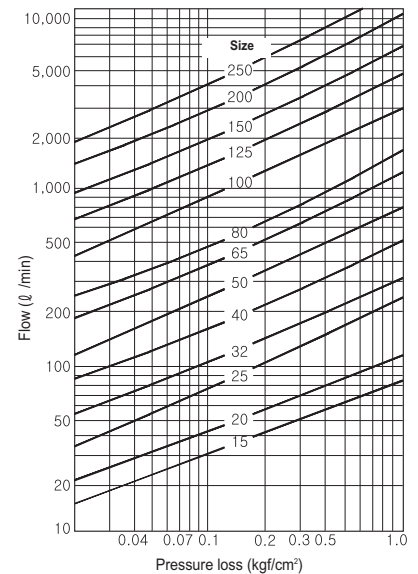

## ■ Dimensional drawing

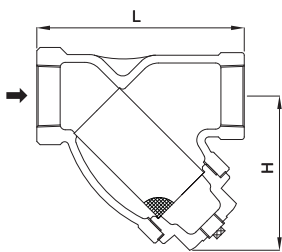

25(1") ~ 50(2")

Type YKY-1

## ■ Dimensional drawing

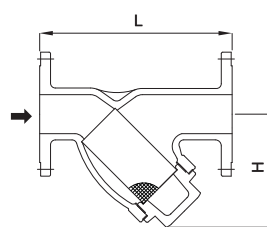

20(3/4")

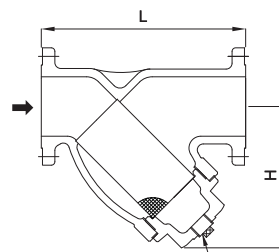

25(1") ~ 50(2")

Type YKY-2

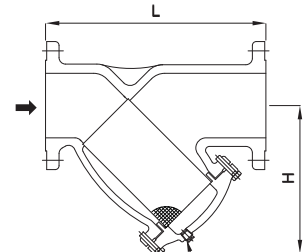

65(2 1/2") ~ 450(18")

# Type YKY-11, 12 Strainer



Type YKY-11



Type YKY-12

## ■ Features

- Approved by the Korean Industrial Standard (KS B1538).
- Extremely fine meshes screen can filter all foreign substances.
- Designed to ensure easy disassembly & assembly, and has a drain plug installed.

## ■ Specifications

Type		YKY-11	YKY-12
Applicable fluid		Steam	
Applicable pressure		Maximum 10 kgf/cm <sup>2</sup> g	
Fluid temperature		220° C below	
End connection		KS PT SCREW	KS 10K FF FLANGE
Materials	Body	GC	
	Screen	STS Wire net	
Hydraulic test pressure		20 kgf/cm <sup>2</sup> g	

## ■ Dimensions

Category	Size	L	H	d	(mm)
YKY-11	15(1/2")	80	60	-	
	20(3/4")	95	69	-	
	25(1")	110	84	3/8"	
	32(1 1/4")	135	105	3/8"	
	40(1 1/2")	160	123	3/8"	
	50(2")	185	134	3/8"	
YKY-12	65(2 1/2")	285	163	1/2"	
	80(3")	305	195	1/2"	
	100(4")	355	265	1/2"	
	125(5")	405	308	3/4"	
	150(6")	464	368	3/4"	
	200(8")	550	484	1"	

## ■ Dimensional drawing

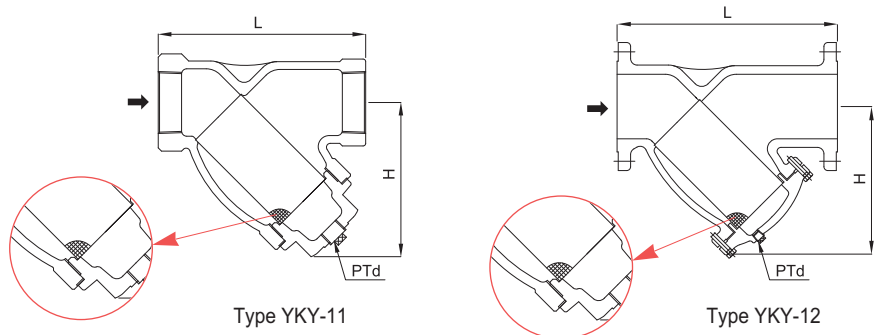

# Type YKY-3 Strainer

This is a Y-type strainer for high pressure. It is compact and has a large filtering area, and thus is an optimal strainer for an automatic valve line.

6



## ■ Specifications

Type	YKY-3	YKY-30
Applicable fluid	Steam, liquid, vapor	
Applicable pressure	Maximum 20 kgf/cm <sup>2</sup> g	Maximum 30 kgf/cm <sup>2</sup> g
Fluid temperature	250° C below	
End connection	KS 20K RF FLANGE	KS 30K RF FLANGE
Materials	Body	GCD450
	Cover	GCD
	Screen	STS
Hydraulic test pressure	40 kgf/cm <sup>2</sup> g	

▶ Made-to-orders are available for 30kgf/cm<sup>2</sup>g.

## ■ Dimensions

Size	L	H	d	Weight(kg)
15(1/2")	160	74	3/8"	1.1
20(3/4")	160	75	3/8"	1.1
25(1")	190	97	3/8"	2.2
32(1 1/4")	220	110	3/8"	3.6
40(1 1/2")	235	117	3/8"	12.4
50(2")	250	140	3/8"	15.1
65(2 1/2")	256	180	3/8"	23.8
80(3")	300	210	3/8"	25.5
100(4")	390	270	1/2"	42.5
125(5")	440	310	1/2"	64.6
150(6")	520	370	3/4"	92.3
200(8")	600	490	1"	155
250(10")	750	565	1"	260
300(12")	892	792	1"	480
350(14")	1052	848	1"	750
400(16")	1044	890	1"	700
450(18")	1087	960	1"	1360
500(20")	1252	965	1"	1450

## ■ Dimensional drawing

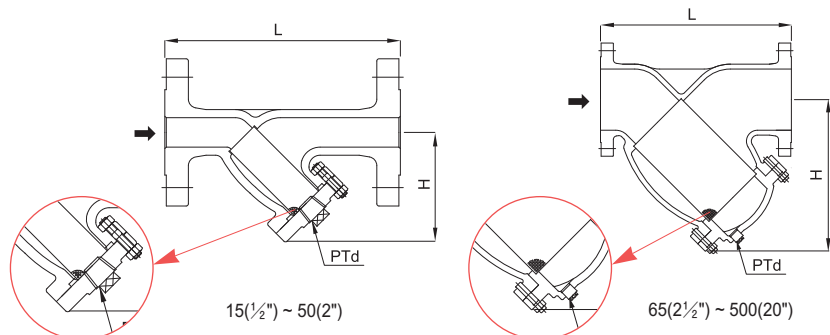

# Type YKY-5B, 6, YBS-6 Strainer

These are Y and U-type strainers of bronze screw type. They are compact and have a large filtering area, and thus are optimal strainers for an automatic valve line.



Type YKY-5B



Type YKY-6



Type YBS-6

## ■ Specifications

Type	YKY-5B	YKY-6	YBS-6(Stop compound valve)
Applicable fluid	Liquid		
Applicable pressure	Maximum 10 kgf/cm <sup>2</sup> g		
Fluid temperature	220° C below		
End connection	KS PT SCREW		
Materials	Body	BC6	BsC1
	Cover	C3771	C3771
	Screen	STS	
Hydraulic test pressure	20 kgf/cm <sup>2</sup> g		

## ■ Dimensions

### » Type YKY-5B

(mm)

Size	L	H	D	Weight(kg)
32(1¼")	124	75	1½"	1.9
40(1½")	138	90	1½"	2.3
50(2")	145	110	2"	3.3

### » Type YKY-6

(mm)

Size	L	H	D
15(½")	58	50	½"
20(¾")	72	60	¾"
25(1")	90	73	1"

### » Type YBS-6

(mm)

Size	L	H	D
15(½")	72	98	½"
20(¾")	90	125	¾"
25(1")	115	153	1"

## ■ Dimensional drawing

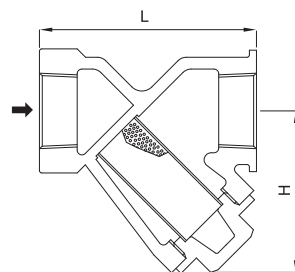

Type YKY-5B

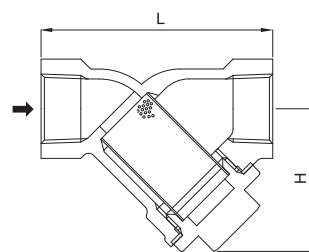

Type YKY-6

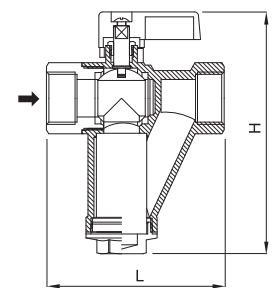

Type YBS-6

# Type YUS-1 Strainer

This is a U-type strainer that is optimal mainly for automatic valves for liquid.



## ■ Features

- Easier disassemble screen structure from the top.
- Internal screen ensuring little input loss with sufficient opening area.

## ■ Specifications

Applicable fluid	Water, oil, air, steam	
Applicable pressure	Maximum 10 kgf/cm <sup>2</sup> g	
Fluid temperature	220° C below	
End connection	KS 10K RF FLANGE	
Materials	Body	GC200
	Screen	STS
Hydraulic test pressure	20 kgf/cm <sup>2</sup> g	

- ▶ Made-to-orders are available for strainers with embedded dual screens for up to 200 meshes.
- ▶ Made-to-orders are available for 20 kgf/cm<sup>2</sup>g.

## ■ Dimensions

Size	L	H1	H2	d	Weight(kg)
20(3/4")	185	98	48	1/2"	8
25(1")	185	98	48	1/2"	8.2
32(1 1/4")	207	122	61	1/2"	9.4
40(1 1/2")	207	122	61	1/2"	10.2
50(2")	230	135	78	1/2"	11.3
65(2 1/2")	270	155	89	1"	18.5
80(3")	305	185	100	1"	21.8
100(4")	385	240	115	1"	48.5
125(5")	424	288	148	1 1/2"	74
150(6")	526	360	165	1 1/2"	95
200(8")	620	487	195	2"	290.8

## ■ Dimensional drawing

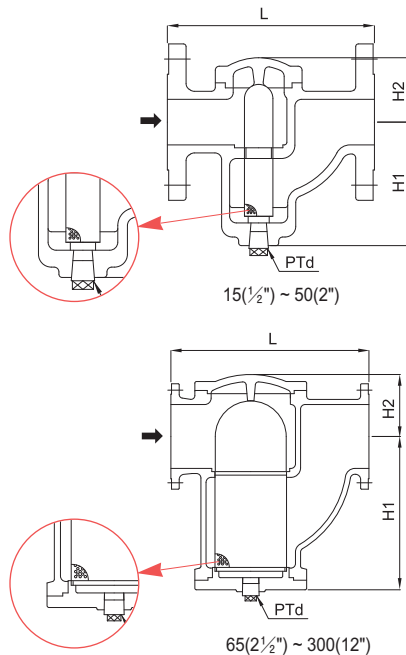

## ■ Pressure loss curve

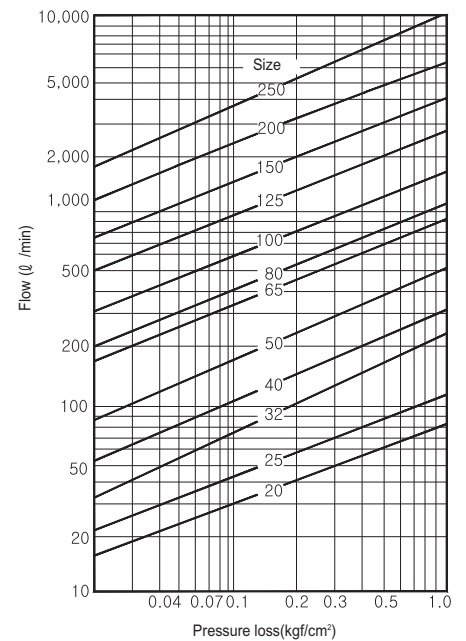

# Type ① - Strainer

This product features an automatic contamination detection function, minimizes pressure loss, and ensures perfect screen cleaning.



## ■ Features

- It ensures easy screen cleaning.
- It has a compact design, and ensures easy installation and handling.
- It minimizes pressure loss.
- It offers a wide range of selection.

## ■ Specifications

Category		For general use
Type		① - Strainer
Designated diameter		50~300A
Applicable fluid		Steam, vapor, liquid
Maximum running temperature		220° C
Applicable pressure		Maximum 10 kgf/cm <sup>2</sup> g
End connection		KS 10K RF / FF FLANGE
Materials	Body	GC200
	Screen	STS
Screen		60 mesh standard
Hydraulic test pressure		15 kgf/cm <sup>2</sup> g

▶ Notes 1: Strainers with a screen of 40, 80, and 100 meshes or with a punch hole only (perforation, 3 X pitch 4) are also available.

Notes 2: Main bodies with GCD material (applicable pressure of 1.6 MPa or below) are also available.

Notes 3: The internal inspection window, differential pressure gauge, and magnetic absorption screen are optional.

## ■ Dimensions

Size	L	H1	H2	A	Weight(kg)
50(2")	210	166	-	112	10.8
65(2½")	250	191	-	160	16.2
80(3")	275	105	-	172	20.4
100(4")	300	131	132	204	30.6
125(5")	360	158	144	256	44.8
150(6")	400	174	170	286	66.2
200(8")	480	225	208	372	109
250(10")	600	280	250	436	194
300(12")	720	328	290	488	303

## ■ Dimensional drawing

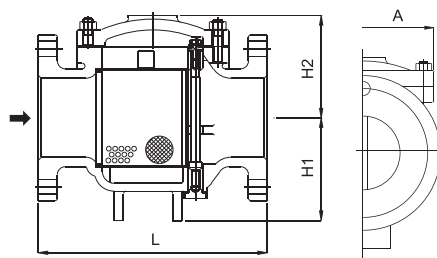

## ■ Pressure loss curve

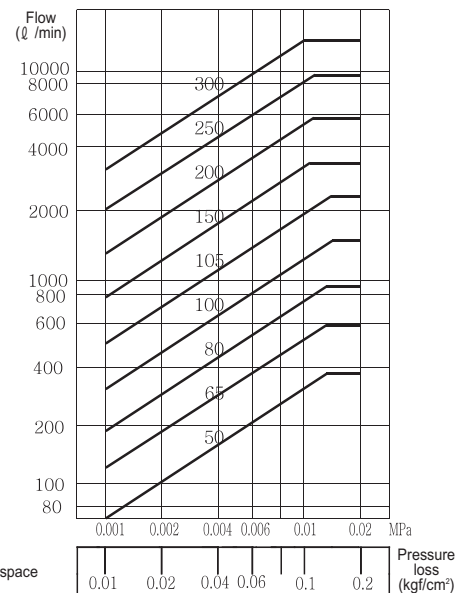

## ■ Spatial comparison

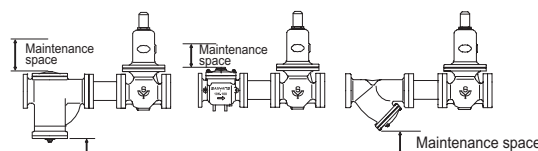

# Type YSS-100 Steam Separator

This product ensures that there is no pressure loss within the pipeline, and is designed in a way that allows an effective water separation function even when there are flow velocity changes. It can thus be used for steam pipelines as well as compressed air pipelines.

6



## Dimensional drawing

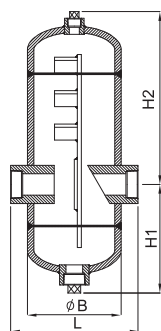

Screwed type

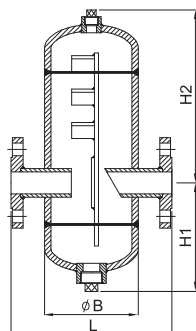

Flanged type

## Features

- Protects process facilities & extends life span by preventing damage caused by Water Hammer in steam system.
- Shield board designed condensate which is separated steam's flow efficiently gathered at discharge point.
- Almost no pressure loss within pipeline, efficiently separates condensate even in extensive flow velocity changes.

## Specifications

Applicable fluid	Steam	
Applicable pressure	Maximum 20 kgf/cm <sup>2</sup> g	
Fluid temperature	214° C below	
End connection	KS PT SCREW	KS 20K RF FLANGE
Materials	SPPS	
Hydraulic test pressure	35 kgf/cm <sup>2</sup> g	

▶ In terms of the end connection, the PT, NPT, KS, and ANSI standards can be applied.

## Dimensions

Size	L	H1	H2	ØB	Weight(kg)
15(1/2")	160(120)	125	175	76	4.1
20(3/4")	200(136)	124	200	89	5.9
25(1")	220(162)	131	223	114	8.9
32(1 1/4")	240(190)	162	258	139	14.1
40(1 1/2")	280(220)	175	320	165	18.7
50(2")	290(220)	209	352	165	21.8
65(2 1/2")	350	246	409	216	37
80(3")	410	305	437	267	60
100(4")	468	367	463	318	85
125(5")	556	350	532	355	136
150(6")	656	375	575	406	195
200(8")	898	421	667	508	313

▶ Made-to-orders are available for water separators with a size of 250 or larger.

▶ Dimensions in parentheses are for the screwed type.

## Application Diagram (Example)

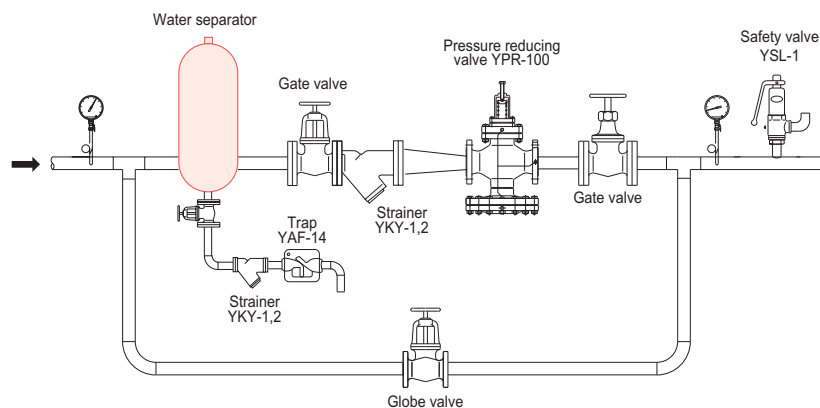

## Installation and application in a steam pipeline

- The diameter of the water separator should be the same as the pipeline diameter. The separator should be installed in a horizontal pipeline.
- The condensate gathered at the discharge point of the separator should be immediately discharged. This is why there is a need to install a float steam trap on the lower part.

# Type YSS-511 Air Separator

This is used in cooling and heating systems to continuously remove air contained in fluid. All air generated by systems can be automatically removed & discharged even at Micro-bubble level. Air can be discharged even at the micro-bubble level.



Type YSS-511S



Type YSS-511F

## ■ Features

- Used in cooling & heating systems to continuously remove air contained in fluid.
- All air generated by systems can be automatically removed & discharged even at Micro-bubble level.
- Air-free water enables optimal operation & prevents noise, corrosion, partial overheating, and mechanical damage.
- Complete thermal insulation effects are achieved in cold and hot water systems with lagging material.

## ■ Specifications

Type	YSS-511S	YSS-511F
Maximum operating pressure	10bar	
Temperature range	0-120° C	
Size	20~25A	50~150A
End connection	KS PT SCREW	KS 10K RF Flange or welding type
Materials	Body	Brass
	Internal parts	Stainless steel
	Seal	EDPM
	Applicable fluid	Water
Drain cock	-	Chromium-coated brass
Waterway	-	15A KS PT SCREW

## ■ Dimensions

Category	Size	L	H1	H2
YSS-511S	20(3/4")	75	20	139
	25(1")	75	20	139
YSS-511F	50(2")	350	232	385
	65(2 1/2")	350	232	385
	80(3")	466	260	606
	100(4")	470	260	606
	125(5")	635	330	764
	150(6")	635	330	764

- ▶ Dimensions are subject to change without prior notice for product quality improvements (performance improvements).
- ▶ Made-to-orders are available for 200A or larger.

## ■ Dimensional drawing

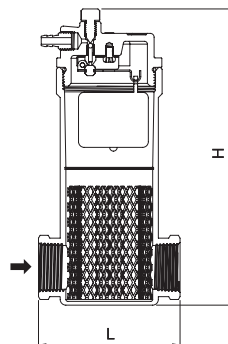

Type YSS-511S

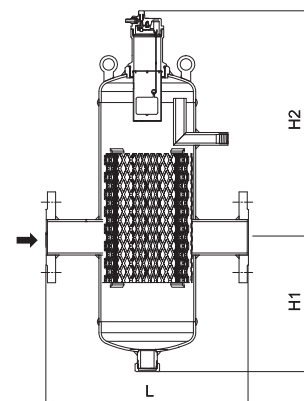

Type YSS-511F



# Type YSS-511 Air Separator

## ■ Air formation process

The amount of air included in water depends on the temperature and pressure. This is because of the Henry's law and physical phenomena related to the amount of air discharged from solution, as seen in the graph below. For example, the amount of air that is discharged when water is heated from 20°C to 80°C at the absolute pressure of 2 bar is the same as 18 l/m<sup>3</sup> of water. The amount of air that needs to be discharged increases in tandem with a rise in temperature and a reduction in pressure. Air is generated in micro-bubble form. With cavitations in cooling and heating systems, the points at which micro bubbles are created in boilers and other instruments are set.

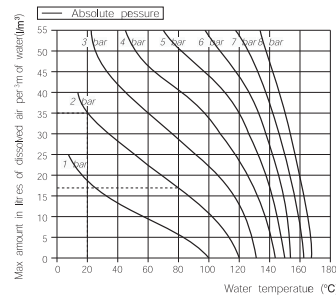

## ■ Boiler's micro bubbles

Micro bubbles are continuously formed according to the temperature of fluid on the surface that is separated from the combustion chamber. Air is transported by water and is condensed at the dew point in a circuit. Air is partially reabsorbed by the cold surface.

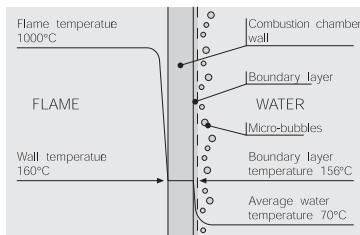

## ■ Cavitation and micro bubbles

Micro bubbles are formed where there is high flow velocity (usually at a pump impeller and a control valve seat) and when the pressure level drops. Such air and vapor micro bubbles lead to cavitation if not moved.

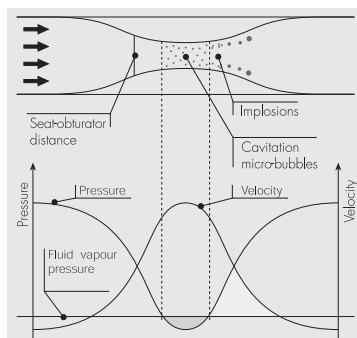

## ■ How it works

An air separator is based on a combination of various physical principles. The moving parts are composed by concentrating metal mesh nets. They allow for rotating movements, which are required to discharge micro bubbles and attach them to the surface. Bubbles have a structure that makes them combine to increase their size until they gain enough momentum to overcome adhesive force. Bubbles move toward the upper part to be discharged by automatic air vent float operation.

## ■ Composition

The air separator is designed so that maintenance for the valve can take place without having to remove the valve from the pipeline. The valve has a connector in the bottom for drain valve connection, and all parts can be disassembled. The automatic air vent on the upper part has a long chamber for float operation, and is designed in a way that ensures that water does not reach the sealing seat. In case of the screwed type, internal parts can be taken out for complete disassembly and assembly. The flanged type and welded type include a drain cock to drain excessive water of a certain water level.

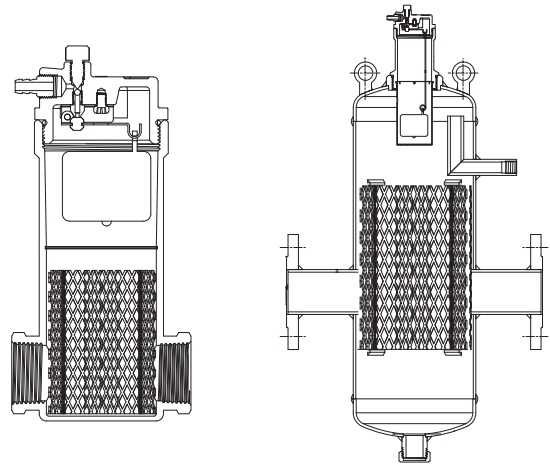

## ■ Pressure loss curve

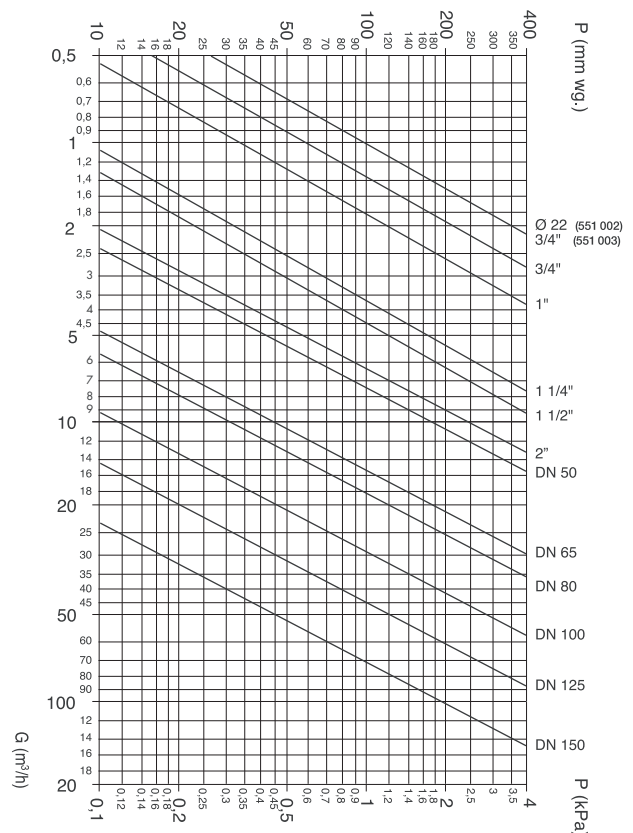

# Bellows Type Expansion Pipe Joint / Flexible Tube

# 7

## Bellows Type Expansion Pipe Joint / Flexible Tube

### Bellows type expansion pipe joint

Type	Size	Applicable pressure (kgf/cm <sup>2</sup> g)	Category	Expansion/contraction length (mm) Expansion length + Contraction length -	End connection	Page
YBJ-1S	25(1")~300(12")	Maximum 10	Single-type steel pipe	+10 -25	KS 10K RF FLANGE	122
YBJ-1W			Double-type steel pipe	+20 -50		
YBJ-2S		Maximum 20	Single-type steel pipe	+10 -25	KS 20K RF FLANGE	123
YBJ-2W			Double-type steel pipe	+20 -50		
YBJ-3S	25(1")~100(4")	Maximum 10	Single-type steel pipe	+10 -25	KS standard socket welding	124
YBJ-3W			Double-type steel pipe	+20 -50		
YBJ-4S			Single-type steel pipe	+10 -25		125
YBJ-4W			Double-type steel pipe	+20 -50		

### Flexible tube

Type	Size	Applicable pressure(kgf/cm <sup>2</sup> g)	Category	End connection	Page
JSY-9B	25(1")~300(12")	Maximum 10, 20	Flexible tube	KS 10, 20K RF FLANGE	126
JSY-9C	25(1")~400(15")		Metal connector		

# Type YBJ-1S, 1W Bellows Type Expansion Pipe Joint

Ⓜ Mark inscription allowed product/ Korea register of shipping model approval

The KS B 1536 bellows type expansion pipe joint is mainly used for cooling, heating, air-conditioning, and sanitary pipelines. It is an expansion pipe joint that absorbs the axial-direction expansion and contraction of a pipeline that occurs according to temperature changes.

## ■ Features

- Standards of the Korean Industrial Standard (KS B 1536), the Association of the United States Army, and the Korean Register of Shipping (KR).
- Offer strong & outstanding level of corrosion resistance & durability : Parts material come into contact with fluid are made of stainless steel and have been molded.
- Outer tube has been used to prevent damage to bellows from outside impact.
- Inner tube adoption ensures little pressure loss of fluid smooth flow & long life span.

## ■ Specifications

Type		YBJ-1S	YBJ-1W
Structure		Single type	Double type
Applicable fluid		Steam, Cold/hot water, Air, Gas, Oil	
Applicable pressure		Maximum 10kgf/cm <sup>2</sup> g	
Fluid temperature		220° C below	
Expansion/contraction length		35mm	70mm
End connection		KS 10K RF FLANGE	
Materials	Bellows, Inner tube	STS	
	Outer tube	SGP	
	Flange	25~150A(SS), 200~250A(GC), 300A(SS)	
Hydraulic test pressure		15kgf/cm <sup>2</sup> g	

- ▶ Do not couple this product with a copper pipeline.
- ▶ 300A or larger are available by made-to-orders.
- ▶ Those used for ANSI #125, #150, and steel flanges are available by made-to-orders.
- ▶ The fixing bolt should be loosened after the hydro-pressure test.

## ■ Dimensions

### » Type YBJ-1S

(mm)

Size	L	Expansion/contraction length		Weight(kg)
		Expansion length	Contraction length	
25(1")	365	10	25	06.4
32(1¼")	365	10	25	06.9
40(1½")	365	10	25	08.3
50(2")	365	10	25	10.9
65(2½")	415	10	25	13.4
80(3")	415	10	25	15.5
100(4")	415	10	25	21.2
125(5")	440	10	25	30.4
150(6")	440	10	25	41.4
200(8")	440	10	25	52.3
250(10")	465	10	25	60.2
300(12")	465	10	25	68.1

### » Type YBJ-1W

(mm)

Size	L	Expansion/contraction length		H	A	B	T	N-øH	Weight(kg)
		Expansion length	Contraction length						
25(1")	680	20	50	100	100	060	2.5	4-12	11.0
32(1¼")	680	20	50	120	100	070	2.5	4-12	13.0
40(1½")	680	20	50	106	106	070	2.5	4-12	15.0
50(2")	680	20	50	130	100	080	2.5	4-15	19.0
65(2½")	780	20	50	140	120	100	3.0	4-15	21.0
80(3")	780	20	50	150	120	110	3.0	4-15	29.5
100(4")	880	20	50	170	120	130	4.0	4-19	43.0
125(5")	880	20	50	200	120	150	5.0	4-19	62.5
150(6")	930	20	50	220	160	180	5.0	4-23	70.0
200(8")	930	20	50	250	220	160	14.0	4-25	135.0
250(10")	980	20	50	300	280	180	14.0	4-27	166.0
300(12")	980	20	50	350	300	200	18.0	4-27	190.0

7



Type YBJ-1S



Type YBJ-1W

## ■ Dimensional drawing

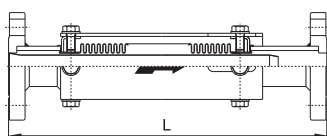

Type YBJ-1S

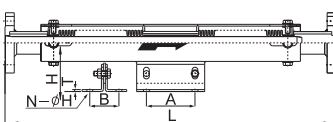

Type YBJ-1W

# Type YBJ-2S, 2W Bellows Type Expansion Pipe Joint

Mark inscription allowed product/ Korea register of shipping model approval

The KS B 1536 bellows type expansion pipe joint is mainly used for cooling, heating, air-conditioning, and sanitary pipelines. It is an expansion pipe joint that absorbs the axial-direction expansion and contraction of a pipe that occurs according to temperature changes.

## ■ Features

- Standards of the Korean Industrial Standard (KS B 1536), the Association of the United States Army, and the Korean Register of Shipping (KR).
- Offer strong & outstanding level of corrosion resistance & durability : Parts material come into contact with fluid are made of stainless steel and have been molded.
- Outer tube has been used to prevent damage to bellows from outside impact.
- Inner tube adoption ensures little pressure loss of fluid, smooth flow & long life span.

## ■ Specifications

Type	YBJ-2S	YBJ-2W
Structure	Single type	Double type
Applicable fluid	Steam, Cold/hot water, Air, Gas, Oil	
Applicable pressure	Maximum 20kgf/cm <sup>2</sup> g	
Fluid temperature	220° C below	
Expansion/contraction length	35mm	70mm
End connection	KS 20K RF FLANGE	
Materials	Bellows, Inner tube	STS
	Outer tube	SPP
	Flange	SS
Hydraulic test pressure	30kgf/cm <sup>2</sup> g	

- ▶ Do not couple this product with a copper pipeline.
- ▶ 350A or larger are available by made-to-orders.
- ▶ Those used for ANSI #125, #150, #300, and steel flanges are available by made-to-orders.
- ▶ The fixing bolt should be loosened after the hydro-pressure test.

## ■ Dimensions

### » Type YBJ-2S

(mm)

Size	L	Expansion/contraction length		Weight(kg)
		Expansion length	Contraction length	
25(1")	365	10	25	06.4
32(1¼")	365	10	25	06.9
40(1½")	365	10	25	08.3
50(2")	365	10	25	10.9
65(2½")	415	10	25	13.4
80(3")	415	10	25	15.5
100(4")	415	10	25	21.2
125(5")	440	10	25	30.4
150(6")	440	10	25	41.4
200(8")	440	10	25	52.3
250(10")	465	10	25	60.2
300(12")	465	10	25	68.1

### » Type YBJ-2W

(mm)

Size	L	Expansion/contraction length		H	A	B	T	N-øH	Weight(kg)
		Expansion length	Contraction length						
25(1")	680	20	50	100	100	60	2.5	4-12	11
32(1¼")	680	20	50	120	100	70	2.5	4-12	13
40(1½")	680	20	50	106	106	70	2.5	4-12	15
50(2")	680	20	50	130	100	80	2.5	4-15	19
65(2½")	780	20	50	140	120	100	3	4-15	21
80(3")	780	20	50	150	120	110	3	4-15	29.5
100(4")	880	20	50	170	120	130	4	4-19	43
125(5")	880	20	50	200	120	150	5	4-19	62.5
150(6")	930	20	50	220	160	180	5	4-23	70
200(8")	930	20	50	250	220	160	14	4-25	135
250(10")	980	20	50	300	280	180	14	4-27	166
300(12")	980	20	50	350	300	200	18	4-27	190



Type YBJ-2S



Type YBJ-2W

## ■ Dimensional drawing

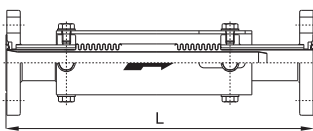

Type YBJ-2S

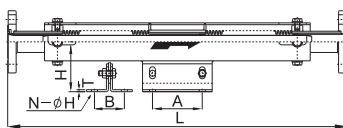

Type YBJ-2W



# Type YBJ-3S, 3W Bellows Type Expansion Pipe Joint (for Copper Pipe)

Ⓜ Mark inscription allowed product/ Korea register of ahipping model approval

This is an expansion pipe joint used for cold water, hot water, or other copper pipelines.

## ■ Features

- Absorb the expansion & contraction of pipelines by temperature changes.
- Stainless steel ensuring high level of corrosion resistance leads little fluid pressure loss : Inner tube materials which come into contact with fluid are made of stainless steel.
- Outer tube has been used to prevent damage to bellows from impact.
- Internal pressure type product prevents noise.

## ■ Specifications

Type		YBJ-3S	YBJ-3W
Structure		Single type	Double type
Applicable fluid		Cold/hot water, Oil, Air	
Applicable pressure		Maximum 10kgf/cm <sup>2</sup> g	
Fluid temperature		220° C below	
Expansion/contraction length		35mm	70mm
End connection		KS D 5578 Dimensions-based socket-welded type	
Materials	Bellows, Inner tube	STS	
	Outer tube	SGP	
	Socket	CuT	
Hydraulic test pressure		15kgf/cm <sup>2</sup> g	

▶ The fixing bolt should be loosened after the hydro-pressure test.

## ■ Dimensions

### ➤ Type YBJ-3S

(mm)

Size	L	Expansion/contraction length		Weight(kg)
		Expansion length	Contraction length	
25(1")	365	10	25	04.1
32(1¼")	365	10	25	04.1
40(1½")	365	10	25	05.2
50(2")	365	10	25	07.1
65(2½")	415	10	25	08.2
80(3")	415	10	25	10.3
100(4")	415	10	25	15.7

### ➤ Type YBJ-3W

(mm)

Size	L	Expansion/contraction length		H	A	B	T	N-øH	Weight(kg)
		Expansion length	Contraction length						
25(1")	680	20	50	100	100	060	2.5	4-12	08.7
32(1¼")	680	20	50	120	100	070	2.5	4-12	10.0
40(1½")	680	20	50	106	100	070	2.5	4-12	11.9
50(2")	680	20	50	130	100	080	2.5	4-15	15.2
65(2½")	780	20	50	140	120	100	3.0	4-15	15.8
80(3")	780	20	50	150	120	110	3.0	4-15	24.3
100(4")	880	20	50	170	120	130	4.0	4-19	37.5

## ■ Dimensional drawing

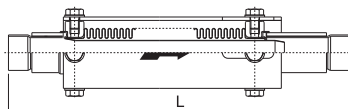

Type YBJ-3S

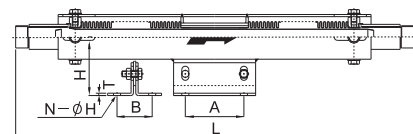

Type YBJ-3W

# Type YBJ-4S, 4W Bellows Type Expansion Pipe Joint (for Steel Pipe)

Mark inscription allowed product/ Korea register of shipping model approval

This is used to absorb the axial-direction expansion and contraction of a pipeline that occurs according to temperature changes. Since it is an internal pressure type, it is buckling-free and ensures smooth expansion/contraction.



Type YBJ-4S



Type YBJ-4W

## ■ Features

- Absorb the expansion & contraction of pipelines by temperature changes.
- Outstanding level of corrosion resistance : Parts materials come into contact with fluid are made of stainless steel.
- Outer tube has been used to prevent damage to the bellows from impact.

## ■ Specifications

Type	YBJ-4S	YBJ-4W
Structure	Single type	Double type
Applicable fluid	Cold/hot water, Oil, Air, Steam	
Applicable pressure	Maximum 10kgf/cm <sup>2</sup> g	
Fluid temperature	220° C below	
Expansion/contraction length	35mm	70mm
End connection	KS D 3507 dimensions-based welded type	
Materials	Bellows	STS
	Outer tube	SGP
	Pipe	SPP
Hydraulic test pressure	15kgf/cm <sup>2</sup> g	

▶ The fixing bolt should be loosened after the hydro-pressure test.

## ■ Dimensions

### » Type YBJ-4S

(mm)

Size	L	Expansion/contraction length		Weight(kg)
		Expansion length	Contraction length	
25(1")	365	10	25	04.1
32(1¼")	365	10	25	04.1
40(1½")	365	10	25	05.2
50(2")	365	10	25	07.1
65(2½")	415	10	25	08.2
80(3")	415	10	25	10.3
100(4")	415	10	25	15.7

### » Type YBJ-4W

(mm)

Size	L	Expansion/contraction length		H	A	B	T	N-øH	Weight(kg)
		Expansion length	Contraction length						
25(1")	680	20	50	100	100	060	2.5	4-12	08.7
32(1¼")	680	20	50	120	100	070	2.5	4-12	10.0
40(1½")	680	20	50	106	100	070	2.5	4-12	11.9
50(2")	680	20	50	130	100	080	2.5	4-15	15.2
65(2½")	780	20	50	140	120	100	3.0	4-15	15.8
80(3")	780	20	50	150	120	110	3.0	4-15	24.3
100(4")	880	20	50	170	120	130	4.0	4-19	37.5

## ■ Dimensional drawing

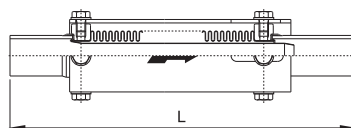

Type YBJ-4S

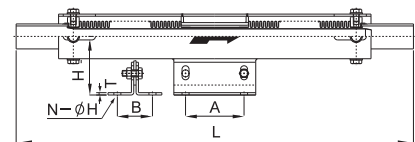

Type YBJ-4W

# Type JSY-9B Flexible Tube

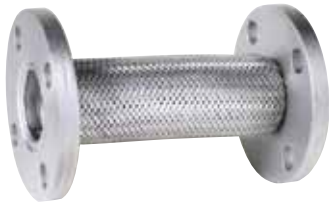

## ■ Features

This product has a short distance among the surfaces and has a structure that allows it to absorb an extensive expansion/contraction length, making it especially ideal for pump connectors.

## ■ Specifications

Applicable fluid		Cold/hot water, Oil, Air, Steam	
Maximum running pressure		Maximum 10kgf/cm <sup>2</sup> g	Maximum 20kgf/cm <sup>2</sup> g
Maximum applicable temperature		220° C below	250° C below
End connection		KS 10K FF FLANGE	KS 20K FF FLANGE
Materials	Bellows	STS	
	Flange	SS	
Hydraulic test pressure		15kgf/cm <sup>2</sup> g	30kgf/cm <sup>2</sup> g

## ■ Dimensional drawing

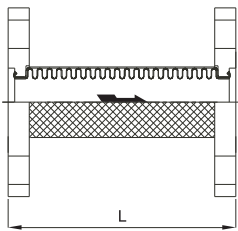

## ■ Dimensions

Size	25(1")	32(1¼")	40(1½")	50(2")	65(2½")	80(3")	(mm)
L	200.0	200.0	230.0	230.0	230.0	230.0	
Weight(kg)	2.5	3.5	3.9	4.2	5.9	6.5	
Size	100(4")	125(5")	150(6")	200(8")	250(10")	300(12")	
L	230.0	280.0	280.0	300.0	300.0	300.0	
Weight(kg)	7.2	10.5	14	17.1	26	40	

# Type JSY-9C Flexible Tube (Tie-Rod Type)



## ■ Features

This product has a simple structure, a short pipeline length, and absorbs a large amount of expansion/contraction and vibration, making it ideal for classic pipelines, tank pipelines, and pump connectors.

## ■ Specifications

Applicable fluid		Cold/hot water, Oil, Air, Steam	
Maximum running pressure		Maximum 10kgf/cm <sup>2</sup> g	Maximum 20kgf/cm <sup>2</sup> g
Applicable temperature		220° C below	250° C below
End connection		KS 10K FF FLANGE	KS 20K FF FLANGE
Materials	Bellows	STS316	
	Flange	SS41	
Hydraulic test pressure		15kgf/cm <sup>2</sup> g	30kgf/cm <sup>2</sup> g

## ■ Dimensional drawing

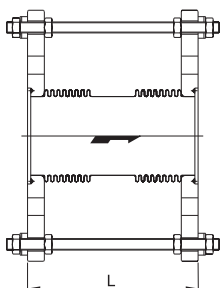

## ■ Dimensions

Size	25(1")	32(1¼")	40(1½")	50(2")	65(2½")	80(3")	100(4")	(mm)
L	90	90	90	130(140)	130(140)	130(140)	130(140)	
Size	125(5")	150(6")	200(8")	250(10")	300(12")	350(14")	400(16")	
L	150(180)	150(180)	150(180)	210(180)	210(240)	210(240)	210(240)	

▶ The length values in parentheses are for 20kgf/cm<sup>2</sup>g

# Data / Bellows Type Expansion Pipe Joint

## ■ How to select a bellows type expansion pipe joint

### ● Sequence of selecting an expansion pipe joint

- 1) Categorize the two ends of a straight pipeline, a branch pipeline, a reducer-using part, a valve installation point, and a curved section of the pipeline as main anchors.
- 2) Identify the pipeline length among the main anchors.
- 3) Calculate the expansion/contraction length for each main anchor section, based on the difference of maximum temperature of applicable fluid, air temperature during installation, and minimum ambient temperature.
- 4) Determine how many joints need to be installed by dividing the expansion/contraction length of each section by the allowed expansion/contraction length of the expansion pipe joint.
- 5) If there is a need to install two or more expansion pipe joints, first select a double type and then a single type.
- 6) Decide on intermediate anchors and guides so that the expansion pipe joint can smoothly engage in axial-direction expansion/contraction operation.

### ● Example of pipeline installation and symbols

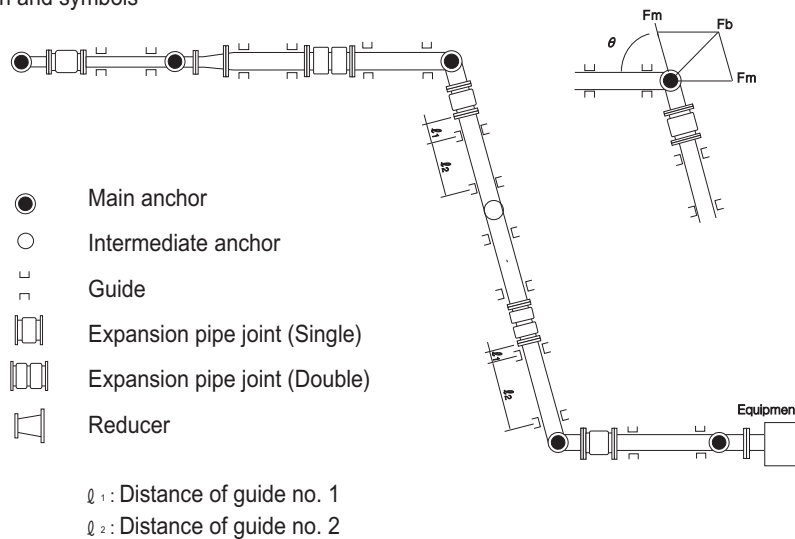

### ● Pipe's expansion/contraction length (based on calculation)

Basic formula  $\Delta l = \alpha \times \Delta t \times L$

Maximum expansion length calculation formula  $\Delta l = \alpha \times (T - t_1) \times L$

Maximum contraction length calculation formula  $\Delta l = \alpha \times (t_1 - t_2) \times L$

$\Delta l$ : Expansion/contraction length of pipe(mm)

$\alpha$ : Pipe's expansion coefficient

Steel pipe :  $12.2 \times 10^{-3} \text{mm/m}^\circ\text{C}$

Copper pipe :  $17.7 \times 10^{-3} \text{mm/m}^\circ\text{C}$

Stainless pipe :  $18.4 \times 10^{-3} \text{mm/m}^\circ\text{C}$

$\Delta t$ : Temperature difference( $^\circ\text{C}$ )

L: Pipeline length(m)

T: Maximum applicable temperature ( $^\circ\text{C}$ )

$t_1$ : Temperature during installation( $^\circ\text{C}$ )

$t_2$ : Minimum ambient temperature( $^\circ\text{C}$ )

※ The expansion/contraction of a pipe is heavily dependent on the temperature of the applied fluid. The pipe expands or contracts according to changes in the maximum running temperature, minimum ambient temperature, etc. based on the temperature at the point of installation.

### ● Deciding on the number of joints

$$N = \frac{\Delta l}{\delta}$$

N : Number installed

$\Delta l$  : Pipe's expansion or contraction length

$\delta$  : Maximum expansion/contraction length

# Data / Bellows Type Expansion Pipe Joint

## ■ Pipe's expansion/contraction length according to temperature changes

» Diagram 1 Expansion/contraction length of a pipe (Expansion/contraction length per 1 m of a pipe)

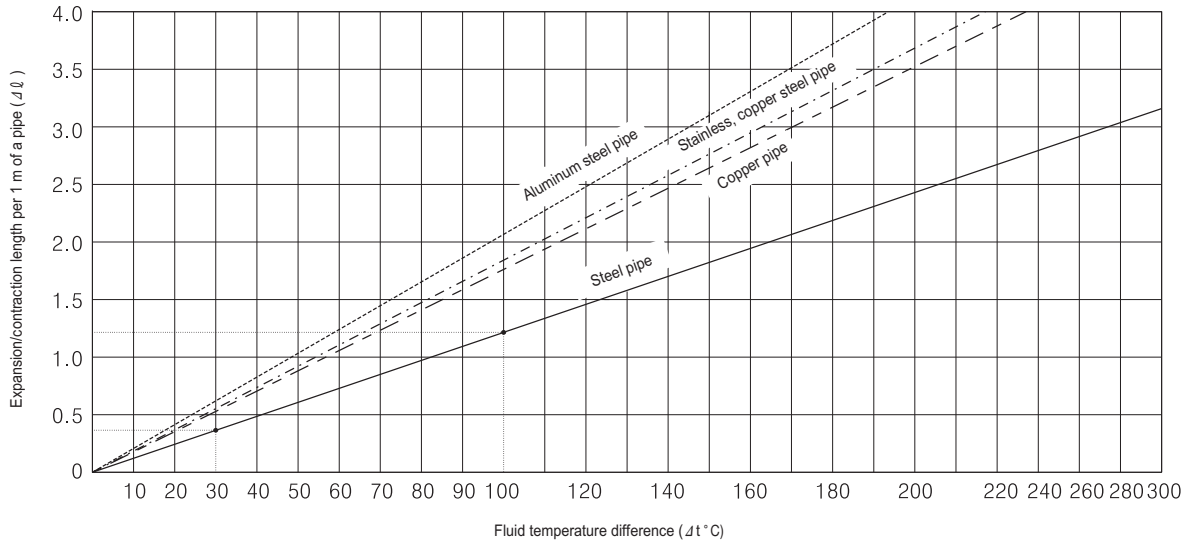

» Table 1 Expansion/contraction length of a pipeline (Expansion/contraction length corresponding to different pipeline lengths)

Pipe type	Pipe length	Fluid temperature difference Δt °C																				Pipe length		
		10	20	30	40	50	60	70	80	90	100	110	120	130	140	150	160	170	180	190	200		210	220
Steel pipe	1	0.122	0.244	0.366	0.488	0.61	0.732	0.854	0.976	1.1	1.22	1.34	1.46	1.59	1.71	1.83	1.95	2.07	2.2	2.32	2.44	2.56	2.68	1
	5	0.61	1.22	1.83	2.44	3.05	3.66	4.27	4.88	5.49	6.1	6.71	7.32	7.93	8.54	9.15	9.76	10.4	11.0	11.6	12.2	12.8	13.4	5
	10	1.22	2.44	3.66	4.88	6.1	7.32	8.54	9.76	11.0	12.2	13.4	14.6	15.9	17.1	18.3	19.5	20.7	22.0	23.2	24.4	25.6	26.8	10
	15	1.83	3.66	5.49	7.32	9.15	11.0	12.8	14.6	16.5	18.3	20.1	22.0	23.8	25.6	27.5	29.3	31.1	32.9	34.8	36.6	38.4	40.3	15
	20	2.44	4.88	7.32	9.76	12.2	14.6	17.1	19.5	22.0	24.4	26.8	29.3	31.7	34.2	36.6	39.0	41.5	43.9	46.4	48.8	51.2	53.7	20
	25	3.05	6.1	9.15	12.2	15.3	18.3	21.4	24.4	27.5	30.5	33.6	36.7	39.7	42.7	45.8	48.8	51.9	54.9	58.0	61.0	64.1	67.1	25
	30	3.66	7.32	11.0	14.6	18.3	22.0	25.6	29.3	32.9	36.6	40.3	43.9	47.6	51.2	54.9	58.6	62.2	65.9	69.5	73.2	76.9	80.5	30
	35	4.27	8.54	12.8	17.1	21.4	25.6	29.9	34.2	38.4	42.7	47.0	51.2	55.5	59.8	64.1	68.3	72.6	76.9	81.1	85.4	89.7	93.9	35
40	4.88	9.76	14.6	19.5	24.4	29.3	34.2	39.0	43.9	48.8	53.7	58.6	63.4	68.3	73.2	78.1	83.0	87.8	92.7	97.6	102.5	107.4	40	
Copper pipe	1	0.177	0.354	0.531	0.708	0.885	1.06	1.24	1.42	1.59	1.77	1.95	2.12	2.30	2.48	2.66	2.83	3.01	3.19	3.36	3.54	3.72	3.89	1
	5	0.885	1.77	2.66	3.54	4.43	5.31	6.2	7.1	7.97	8.85	9.74	10.6	11.5	12.4	13.3	14.2	15.1	15.9	16.8	17.7	18.6	19.5	5
	10	1.77	3.54	5.31	7.1	8.85	10.6	12.4	15.9	17.7	19.5	21.2	23.0	24.8	26.6	28.3	30.1	31.9	33.6	35.4	37.2	39.0	40.8	10
	15	2.66	5.31	7.97	10.6	13.3	15.9	18.6	21.2	23.9	26.6	29.2	31.9	34.5	37.2	39.8	42.5	45.1	47.8	50.5	53.1	55.8	58.4	15
	20	3.54	7.1	10.6	14.2	17.7	21.2	24.8	28.3	31.9	35.4	38.9	42.5	46.0	49.6	53.1	56.6	60.2	63.7	67.3	70.8	74.3	77.9	20
	25	4.43	8.85	13.3	17.7	22.1	26.6	31.0	35.4	39.8	44.3	48.7	53.1	57.5	62.0	66.4	70.8	75.2	79.7	84.1	88.5	92.9	97.4	25
	30	5.31	10.6	15.9	21.2	26.6	31.9	37.2	42.5	47.8	53.1	58.4	63.7	69.0	74.3	79.7	85.0	90.3	95.6	100.9	106.2	111.5	116.8	30
	35	6.2	12.4	18.6	24.8	31.0	37.2	43.4	49.6	55.8	62.0	68.2	74.3	80.5	86.7	92.9	99.1	105.3	111.5	117.7	123.9	130.0	136.3	35
40	7.1	14.2	21.2	28.3	35.4	42.5	49.6	56.6	63.7	70.8	77.9	85.0	92.0	99.1	106.2	113.3	120.4	127.4	134.5	141.6	148.7	155.8	40	
Stainless steel pipe	1	0.184	0.368	0.552	0.736	0.92	1.1	1.29	1.47	1.66	1.84	2.02	2.21	2.39	2.58	2.76	2.94	3.13	3.31	3.5	3.68	3.86	4.04	1
	5	0.92	1.84	2.76	3.68	4.6	5.52	6.44	7.36	8.28	9.2	10.1	11.0	12.0	12.9	13.8	14.7	15.6	16.6	17.5	18.4	19.3	20.2	5
	10	1.84	3.68	5.52	7.36	9.2	11.0	12.9	14.7	16.6	18.4	20.2	22.1	23.9	25.8	26.6	29.4	31.3	33.1	35.0	36.8	38.6	40.5	10
	15	2.76	5.52	8.28	11.0	13.8	16.6	19.3	22.1	24.8	27.6	30.4	33.1	35.9	38.6	41.4	44.2	46.9	49.7	52.4	55.2	58.0	60.7	15
	20	3.68	7.36	11.0	14.7	18.4	22.1	25.8	29.4	33.1	36.8	40.5	44.2	47.8	51.5	55.2	58.9	62.6	66.2	69.6	73.6	77.3	81.0	20
	25	4.6	9.2	13.8	18.4	23.0	27.6	32.2	36.8	41.4	46.0	50.6	55.2	59.8	64.4	69.0	73.6	78.2	82.8	87.4	92.0	96.6	101.2	25
	30	5.52	11.0	16.6	22.1	27.6	33.1	38.6	44.2	49.7	55.2	60.7	66.2	71.8	77.3	82.8	88.3	93.2	99.4	104.9	110.4	115.9	121.4	30
	35	6.44	12.9	19.3	25.8	32.2	38.6	45.1	51.5	58.0	64.4	70.8	77.3	83.7	90.2	96.6	103	109.5	115.9	122.4	128.8	135.2	141.7	35
40	7.36	14.7	22.1	29.4	36.8	44.2	51.5	58.9	66.2	73.6	81.0	88.3	95.7	103	110.4	117.8	125.1	132.5	139.8	147.2	154.6	161.9	40	

# Data / Bellows Type Expansion Pipe Joint

## ■ Example of selecting a bellows type expansion pipe joint

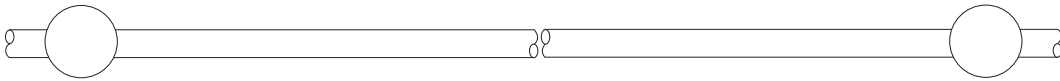

- Pipeline length( $l$ ) = 30m
- Maximum applicable temperature( $t_1$ ) = 110°C
- Temperature during installation = -10°C
- If the ambient temperature ( $t_3$ ) equals 20°C during installation

**First :** Calculate the pipe's expansion/contraction length.

The temperature difference of the pipe's expanding axis is  $\Delta t_1 = t_1 - t_3 = 110 - 20 = 90^\circ\text{C}$

The temperature difference of the pipe's contracting axis is  $\Delta t_2 = t_3 - t_2 = 20 - (-10) = 30^\circ\text{C}$ .

While referring to the pipe's expansion/contraction length (Table 1), find the point where the pipe's length is 30 m when the fluid's temperature difference is ( $\Delta t$ )90°C, and make a perpendicular connection. The length of pipe expansion

( $\Delta l_1$ ) is 32.9 mm. Find the point where the pipe's length is 30 m when the fluid's temperature difference is ( $\Delta t$ )30°C, and make a perpendicular connection. The length of pipe contraction ( $\Delta l_2$ ) is 11.00 mm.

**Second :** Once the expansion/contraction length is determined, decide on the type of the bellows type expansion pipe joint and the number of joints.

When selecting the type YBJ-1S (single), which is a product approved with a Korean Industrial Standard mark

In case of a single bellows type expansion pipe joint

Pipe-expanding side ( $\delta = 50\text{mm}$ )  
Pipe-contracting side ( $\delta = 20\text{mm}$ )

Therefore,

$$n = \frac{\Delta l_1}{\delta} = \frac{32.9}{25} = 1.32 \text{ joints}$$

$$n = \frac{\Delta l_2}{\delta} = \frac{11.0}{10} = 1.1 \text{ joints}$$

Since the number of joints of the side that is bigger between the pipe-expanding side and pipe-contracting side is adopted, the number of the single bellows type expansion pipe joint becomes two.

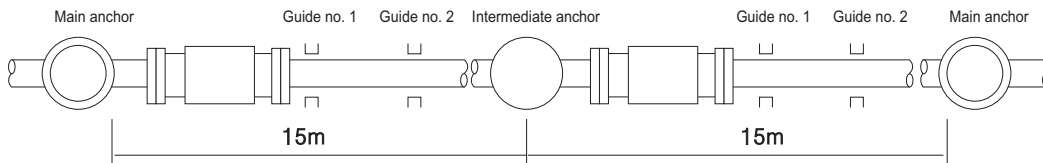

When selecting the type YBJ-2W (double), which is a product approved with a Korean Industrial Standard mark

In case of a double bellows type expansion pipe joint

Pipe-expanding side ( $\delta = 50\text{mm}$ )  
Pipe-contracting side ( $\delta = 20\text{mm}$ )

Therefore,

$$n = \frac{\Delta l_1}{\delta} = \frac{32.9}{50} = 0.61 \text{ joints}$$

$$n = \frac{\Delta l_2}{\delta} = \frac{11.0}{20} = 0.55 \text{ joints}$$

Since the number of joints of the side that is bigger between the pipe-expanding side and pipe-contracting side is adopted, the number of the double bellows type expansion pipe joint becomes one.

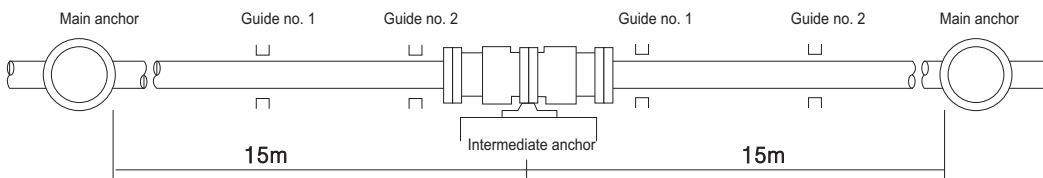

# Data / Bellows Type Expansion Pipe Joint

## ■ Deciding on where to install anchors and guides

### ● Installation of main anchor

- Installation location
  - Install at two ends of straight pipeline section
  - Install in branch pipeline
  - Reducer and valve installation points

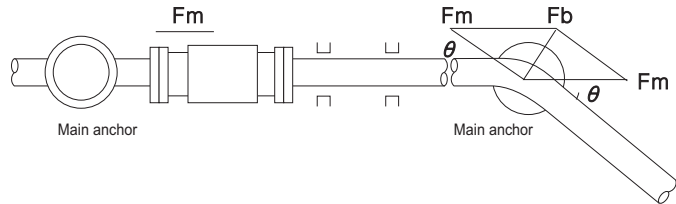

#### 1. Load on main anchor in straight pipeline

$$F_m = (A_e \times P) + (K \times \delta)$$

$$F_m = F_p + F_s$$

$$F_p = A_e \times P$$

$$F_s = K \times \delta$$

$F_m$  : Load on main anchor in straight pipeline section (kgf)

$F_p$  : Thrust force caused by internal pressure (kgf)

$F_s$  : Compressive load on expansion pipe joint (kgf)

$A_e$  : Effective area of bellows (cm<sup>2</sup>)

$P$  : Fluid pressure (kgf/cm<sup>2</sup>)

$K$  : Spring constant of bellows (kgf/mm)

$\delta$  : Expansion/contraction length (mm)

#### 2. Load on main anchor in curved pipeline

$$F_c = \frac{2A\rho V^2}{g} \times \sin \frac{\theta}{2}$$

$$F_b = 2F_m \cdot \sin \frac{\theta}{2} + F_c$$

$F_b$  : Load on main anchor in curved pipeline section (kgf)

$F_c$  : Load caused by centrifugal force of fluid (kgf)

$\theta$  : Angle of curved pipeline section

$A$  : Cross section of pipe (cm<sup>2</sup>)

$\rho$  : Fluid density (kg/cm<sup>3</sup>)

$V$  : Fluid speed (cm/mm)

$g$  : Gravity acceleration (cm/mm)

### ● Installation of intermediate anchor

- Installation location
  - If there are two or more expansion pipe joints between main anchors, install an intermediate anchor in the middle
  - Fixing pole area of double expansion pipe joint

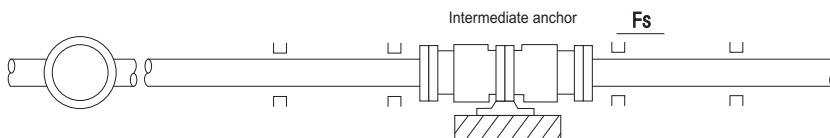

$$F_i = F_s = K \times \delta$$

$F_i$  : Load on intermediate anchor (kgf)

$F_s$  : Compressive load on expansion pipe joint (kgf)

$K$  : Spring constant of bellows (kgf/mm)

$\delta$  : Expansion/contraction length (mm)

# Data / Bellows Type Expansion Pipe Joint

## ■ Deciding on where to install anchors and guides

### ● Installation of guide

Guide no. 1 and guide no. 2 are installed to prevent buckling from pipeline expansion and bending from the pipeline's own weight. Install guide no. 1 in close proximity to the expansion pipe joint. Refer to the following formula and chart for the installation interval of guide no. 2.

$$l_2 = \sqrt{\frac{\pi^2 EI}{F \cdot W}}$$

- $l_2$  : Guide no. 2 interval ..... (cm)
- W : Buckling load ..... (kgf)
- E : Young's modulus ..... (kgf/cm<sup>2</sup>)
- I : Moment of inertia ..... (cm<sup>4</sup>)
- f : Safety factor

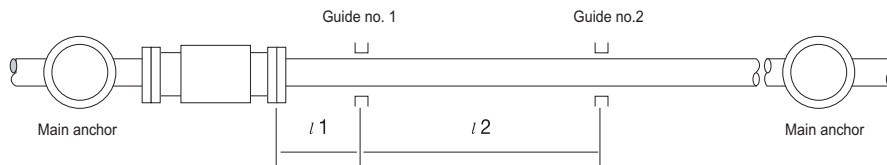

➤ Table 1 Expansion/contraction length of a pipeline (Expansion/contraction length corresponding to different pipeline lengths)

Category / Size	~40	50	65	80	100	125	150	200	250
Guide no. 1 : $l_1$ (m)	0.15	0.2	0.25	0.3	0.4	0.5	0.6	0.8	1.0
Guide no. 2 : $l_2$ (m)	2.5	3.0	4.0	5.0	6.0	8.0	10	12	14

➤ Chart 2. Guide interval to prevent buckling

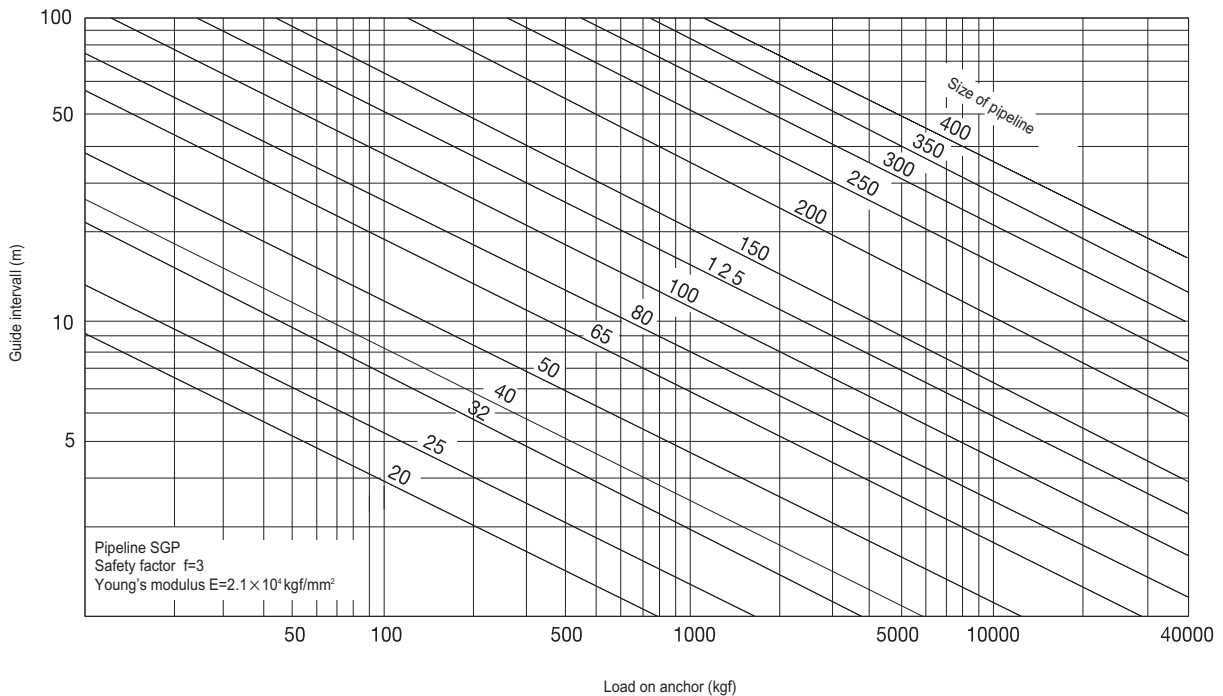

# Data / Bellows Type Expansion Pipe Joint

## ■ Cautions for installation

The following cautions need to be taken for installation to ensure maximum performance of the bellows type expansion pipe joint.

1. Fix the two ends of the straight pipeline and where the pipeline is curved.

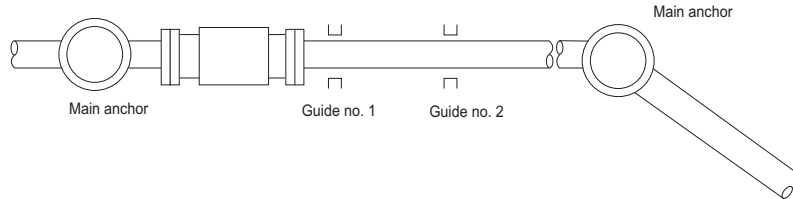

2. There are cases where several bellows type expansion pipe joints are installed consecutively when the length of the straight pipeline is long. In such cases, an intermediate anchor needs to be installed in the middle of each bellows type expansion pipe joint.

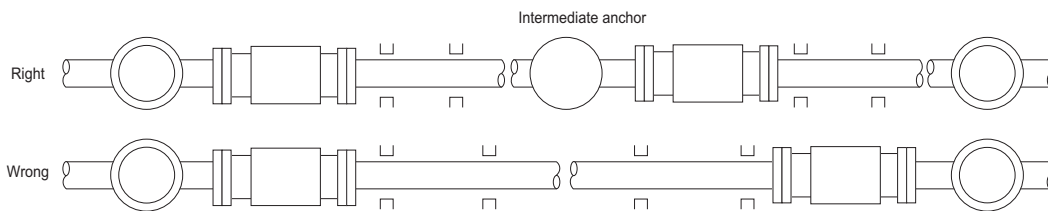

3. Points where main anchors and intermediate anchors are installed need to be sufficiently strong to withstand the loaded strength. Since the same level of load is applied to a double bellows type expansion pipe joint as an intermediate anchor, a fixing pole should be installed.

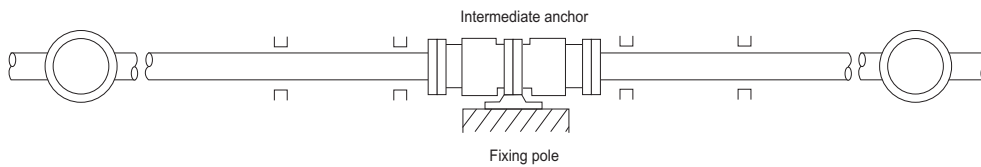

4. A main anchor should be installed when the size of a pipeline changes due to the use of an expansion pipe (reducer).

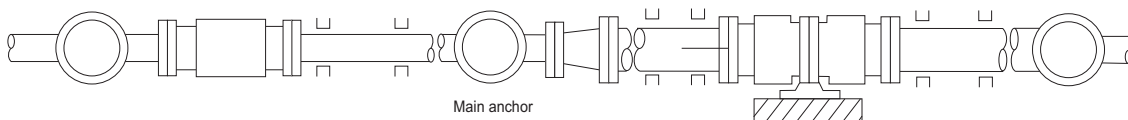

5. Install a single bellows type expansion pipe joint close to an anchor as much as possible. Install a double bellows type expansion pipe joint in the middle of two anchors.

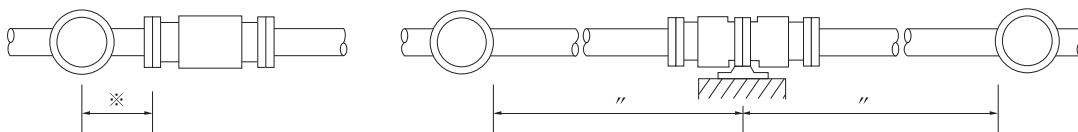

6. The weight of the pipeline coupled with a bellows type expansion pipe joint and other weight should not directly apply to the bellows type expansion pipe joint. In addition, make sure that returning force is not applied.

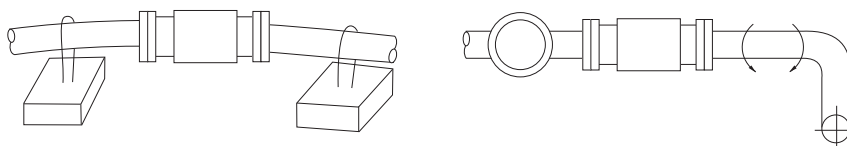

7. Remove bolts or nuts used for fixing surfaces after installation.
8. When applying thermal insulations to a bellows type expansion pipe joint, do not install a lagging material on the expansion/contraction operation part.

# Data / Bellows Type Expansion Pipe Joint

## ■ Cautions for handling

When using bellows, there is a need to install them after considering several matters from a professional point of view. There are simple precautionary measures that need to be taken when installing bellows in a pipeline. Serious accidents are caused by inattentiveness in handling bellows, rather than defects of the bellows.



(1) Do not use the product for a long straight line (pipeline).

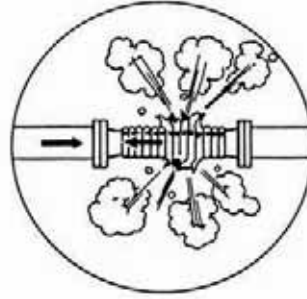

(2) Install the product so that the direction of the arrow indicated on the product is in line with the direction of the fluid' flow.

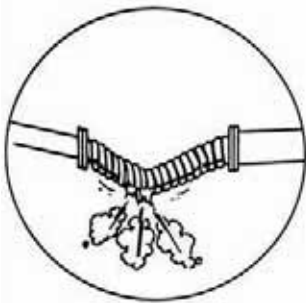

(3) Make sure that the pipeline diameter and weight, etc. is in compliance with the standard of the bellows coupling parts.

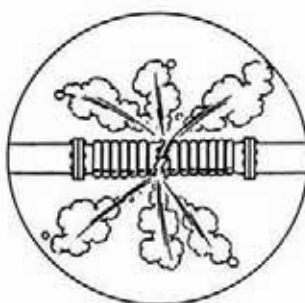

(4) Do not use out-of-spec bellows.

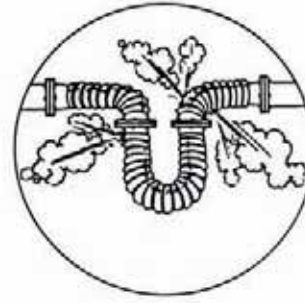

(5) When installing two or more bellows in a straight pipeline section, consider expansion/contraction capacity individually.

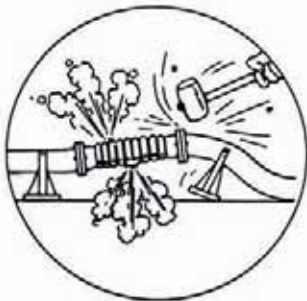

(6) Do not cause outside impact.

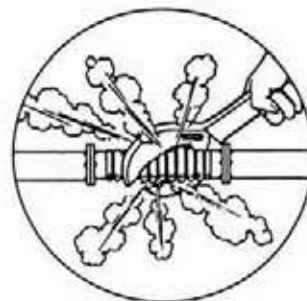

(7) Do not touch the bellows wrinkles without good reason.



# Ball / Slip / Multi Joint

# 8

## Ball / Slip / Multi Joint



### Ball / slip / Multi joint

Type	Size	Applicable pressure (kgf/cm <sup>2</sup> g)	Materials (Body)	Applicable fluid	Page
BG/BI series	32(1¼")	10, 20, 30	GB, SUS, STPG, SCPH2, GCD	Sat. Steam, Superheat Steam, Oil, Water, Gas	136
SIS/SID series					137
SGS/SGD series					138
MJ-1/MJ-2 series					139
MJ-3 series	50(2")				140
BSI series	32(1¼")				141
UG-1 series					142

# BG / BI Type Ball Joint

With the grand packing type, it is easy to install, and has a strong and simple internal structure.

It absorbs omni-directional displacements and is applied for thermal expansion, contraction, and ground subsidence. The injection packing type absorbs omni-directional displacements and allows maintenance during operation.



Grand Type



Injection Type

## Dimensional drawing

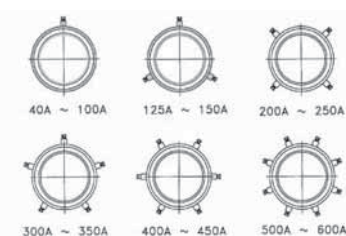

Packing Cylinder Orientation

## Features

- Grand & injection type packing ball joint.
- Absorbs omni-directional displacements & cover extremely high-temperature fluid.
- Absorb pipeline's expansion or contraction from thermal expansion outcome.
- Protect pipelines, buildings, facilities, etc. from ground damage.
- Absorb pipeline displacements which result from ground subsidence or transformation of large storage tanks.
- Absorb vibration, distortions, etc. generated from pumps & turbines.
- Maintenance is available even during operation with full of fluid in the pipeline.

## Specifications

Type		BG series	BI series
Applicable fluid		Sat. Steam, Superheat Steam, Oil, Water, Gas	
Maximum running pressure		10, 20, 30kg/cm <sup>2</sup> g	
Maximum applicable temperature		250° C	250° C (Special orders are available for 250° C)
Maximum displacement angle		15~30°	
Materials	Body	GB, STS, STPG, SCPH2, GCD	
	Ball	GB, SUS, SC49	
	Packing	Teflon+Grafoil (SG NO.100)	Grafoil (SI NO.700)

▶ Clients can choose materials when placing an order.

## Dimensions

Size	L	H
32(1¼")	175	67.5
40(1½")	175	70
50(2")	190	77.5
65(2½")	190	87.5
80(3")	235	92.5
100(4")	250	105
125(5")	305	125
150(6")	355	140
200(8")	390	165
250(10")	420	200
300(12")	445	222.5
350(14")	505	245
400(16")	575	280
450(18")	615	620.0
500(20")	645	337.5
550(22")	685	372.5
600(24")	685	397.5

▶ Other pipe diameters are available by made-to-orders.

## Dimensional drawing

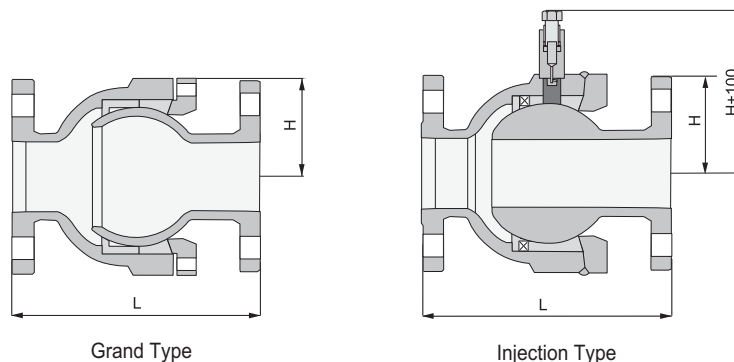

# SI Type Slip Joint

As an injection packing type, it absorbs one-way (two-way) displacements and is applied for thermal expansion and contraction. Maintenance can be made during operation, thanks to injection packing.



SIS Single Type



SID Double Type

## ■ Features

- Injection packing type double slip joint.
- Absorb straight line direction displacements : It can be used for extremely high-temperature fluid.
- Internal & external guide structure : It has longer life span than other conventional slip joints.
- External guide with outstanding lubrication ensures smooth slip.
- Safe packing injection is available under internal pressure.

## ■ Specifications

<b>Applicable fluid</b>		Sat. Steam, Superheat Steam, Oil, Water, Gas
<b>Maximum running pressure</b>		10, 20, 30kg/cm <sup>2</sup> g
<b>Maximum applicable temperature</b>		250° C (Special orders are available for 250° C)
<b>Materials</b>	<b>Body</b>	GB, SUS, STPG, SCPH2, GCD
	<b>Sleeve</b>	GB, SUS, SC49
	<b>Packing</b>	Grafoil (SI NO.800)

▶ The live loading method and dust-cover attachment are available by made-to-orders.

## ■ Dimensions

Size	L (Single)	L (Double)	H
32(1¼")	573	960	67.5
40(1½")	573	960	70
50(2")	573	960	77.5
65(2½")	592	978	87.5
80(3")	608	1,010	92.5
100(4")	639	1,023	105
125(5")	666	1,152	125
150(6")	705	1,153	140
200(8")	705	1,153	165
250(10")	771	1,234	200
300(12")	936	1,260	222.5
350(14")	954	1,296	245
400(16")	987	1,309	280
450(18")	1,159	1,349	620
500(20")	1,166	1,501	337.5
550(22")	1,219	1,519	327.5
600(24")	1,320	1,519	397.5

- ▶ The flanged type and the welding type have the same dimensions.
- ▶ The dimensions above are those for the full open state.
- ▶ These specifications are subject to change for product quality improvements.

## ■ Dimensional drawing

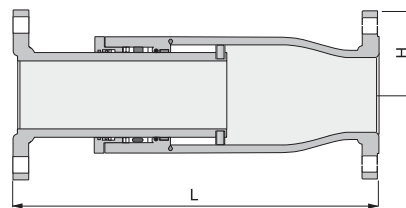

Single Type

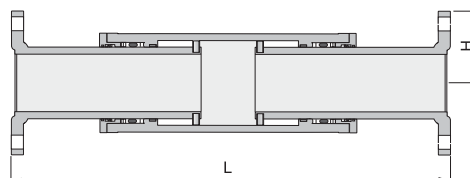

Double Type

## ■ Dimensional drawing

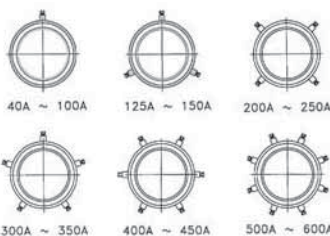

Packing Cylinder Orientation

# SG Type Slip Joint

As a grand packing type, this absorbs one-way direction (two-way direction) displacements, and is applied for thermal expansion and contraction. Thanks to the adoption of the live loading method, simple maintenance is ensured.



SGS Single Type



SGD Double Type

## ■ Features

- Injection packing type single slip joint.
- Absorb displacements in a straight line direction.
- Internal & external guide structure has longer life span than other conventional slip joints.
- External guide with outstanding lubrication ensures smooth slip.
- Highly resistant to pipeline vibration & distortions by adopted live loading method.

## ■ Specifications

<b>Applicable fluid</b>		Sat. Steam, Superheat Steam, Oil, Water, Gas
<b>Maximum running pressure</b>		10, 20, 30kg/cm <sup>2</sup> g
<b>Maximum applicable temperature</b>		250° C (Special orders are available for 250° C)
<b>Materials</b>	<b>Body</b>	GB, SUS, STPG, SCPH2, GCD
	<b>Sleeve</b>	GB, SUS, SC49
	<b>Packing</b>	Teflon+Grafoil (SI NO.800)

▶ The live loading method and dust-cover attachment are available by made-to-orders.

## ■ Dimensions

Standard	L (Single)	L (Double)	H
32(1¼")	573	960	67.5
40(1½")	573	960	70
50(2")	573	960	77.5
65(2½")	592	978	87.5
80(3")	608	1,010	92.5
100(4")	639	1,023	105
125(5")	666	1,152	125
150(6")	705	1,153	140
200(8")	705	1,153	165
250(10")	771	1,234	200
300(12")	936	1,260	222.5
350(14")	954	1,296	245
400(16")	987	1,309	280
450(18")	1,159	1,349	620
500(20")	1,166	1,501	337.5
550(22")	1,219	1,519	327.5
600(24")	1,320	1,519	397.5

- ▶ The flanged type and the welding type have the same dimensions.
- ▶ The dimensions above are those for the full open state.
- ▶ These specifications are subject to change for product quality improvements.

## ■ Dimensional drawing

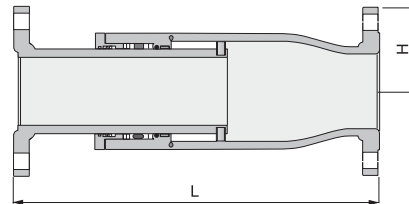

SGS Single Type

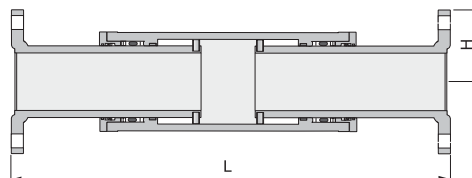

SGD Double Type

# MJ Type Ball & Slip Joint

As an injection packing type, this product absorbs omni-directional displacements, and is applied for thermal expansion, contraction, and ground subsidence.

Maintenance can be made during operation, thanks to injection packing.



MJ-1 Single Type



MJ-2 Double Type

## ■ Features

- Multi-joint type functions combined ball & slip joint.
- Absorb pipeline expansion and contraction results from thermal expansion.
- Protect pipelines, buildings, facilities, etc. from ground damage.
- Absorb pipeline displacements result from ground subsidence or transformation of large storage tanks.
- Used for hydraulic equipment, petrochemicals, mines, agricultural sites, cable facilities, and various plants.

## ■ Specifications

Applicable fluid		Sat. Steam, Superheat Steam, Oil, Water, Gas
Maximum running pressure		10, 20, 30kg/cm <sup>2</sup> g
Maximum applicable temperature		250° C (Special orders are available for 250° C)
Materials	Body	GB, SUS, STPG, SCPH2, GCD
	Sleeve	GB, SUS, SC49
	Packing	Grafoil (SG NO.800)

## ■ Dimensions

Size	L (Single)	L (Double)	H	θ°
32(1¼")	573	960	67.5	8
40(1½")	573	960	70	8
50(2")	573	960	77.5	4.3
65(2½")	592	978	87.5	4.3
80(3")	608	1,010	92.5	4.3
100(4")	639	1,023	105	4.3
125(5")	666	1,152	125	4.3
150(6")	705	1,153	140	4.3
200(8")	705	1,153	165	4.3
250(10")	771	1,234	200	4.3
300(12")	936	1,260	222.5	4.3

- ▶ The flanged type and the welding type have the same dimensions.
- ▶ The dimensions above are those for the full open state.
- ▶ These specifications are subject to change for product quality improvements.

## ■ Dimensional drawing

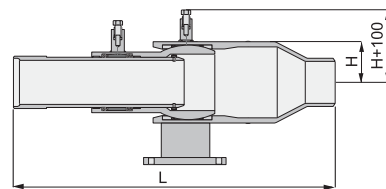

MJ-1 Single Type

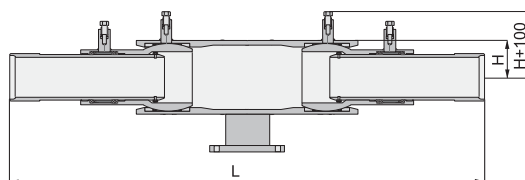

MJ-2 Double Type

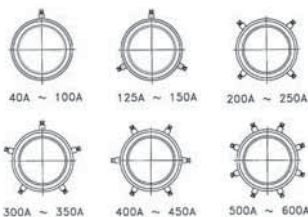

Packing Cylinder Orientation

# MJ-3 Multi Joint

As a grand packing type, this product absorbs omni-directional displacements, and is suitable for bending, expansion/contraction, rotational movements, and various fluid control facilities. It enables effective measures against external stress, such as ground subsidence and earthquakes.

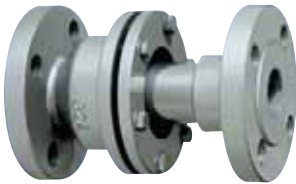

## ■ Features

- Reduce installation space as functions combined ball & slip joint.
- Absorb pipeline expansion & contraction results from thermal expansion.
- Protect pipelines, buildings, facilities, etc. from ground damage.
- Absorb pipeline displacements result from ground subsidence or transformation of large storage tanks.
- Used for hydraulic equipment, petrochemicals, mines, agricultural sites, cable facilities, and various plants.

## ■ Specifications

<b>Applicable fluid</b>		Sat. Steam, Superheat Steam, Oil, Water, Gas
<b>Maximum running pressure</b>		10, 20, 30kg/cm <sup>2</sup> g
<b>Maximum applicable temperature</b>		250° C
<b>Maximum displacement angle</b>		15~30°
<b>Materials</b>	<b>Body</b>	GB, SUS, STPG, SCPH2, GCD
	<b>Sleeve</b>	GB, SUS, SC49
	<b>Packing</b>	Teflon+Grafoil (SG NO.100)

- ▶ The live loading method and dust-cover attachment are available by made-to-orders.
- ▶ The injection type is available by made-to-orders.

## ■ Dimensions

Size(mm)	Flanged type			Welding type			Torque (kgf.m)
	L(mm)	F(mm)	E(mm)	L(mm)	(mm)	E (mm)	
50(2")	210	121	40	210	121	40	25
65(2½")	230	141	40	230	141	40	35
80(3")	260	159	40	260	159	40	55
100(4")	280	195	40	280	195	40	80
125(5")	300	225	45	300	225	45	135
150(6")	310	255	50	310	255	50	190
200(8")	360	323	60	360	323	60	310

## ■ Dimensional drawing

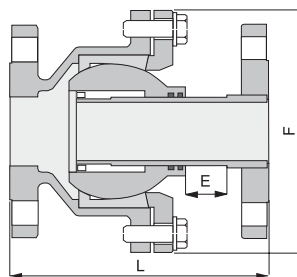

Flanged Type

# BSI Multi Joint

As an injection packing type, this product absorbs omni-directional displacements, and is applied for thermal expansion and contraction. Maintenance can be made during operation, thanks to injection packing.



## ■ Features

- Functions combined ball and slip joint, effectively uses both strengths.
- Absorb pipeline expansion & contraction which results from thermal expansion.
- Protect pipelines, buildings, facilities, etc. from ground damage.
- Used for hydraulic equipment, petrochemicals, mines, agricultural sites, cable facilities, and various plants.
- Absorb high-rise building's sway & building shortening.

## ■ Specifications

Applicable fluid		Sat. Steam, Superheat Steam, Oil, Water, Gas
Maximum running pressure		10, 20, 30kg/cm <sup>2</sup> g
Maximum applicable temperature		250° C (Special orders are available for 250° C or higher)
Materials	Body	GB, SUS, STPG, SCPH2, GCD
	Slip/Ball	GB, SUS, SC49
	Packing	Grafoil (SI NO.800)

## ■ Dimensions (Tr+100 standard)

Size	L (TR100 standard)	Size	L (TR100 standard)
32(1¼")	600	100(4")	690
40(1½")	600	125(5")	770
50(2")	615	150(6")	830
65(2½")	625	200(8")	850
80(3")	680	250(10")	910

- ▶ These specifications are subject to change for product quality improvements.
- ▶ Other sizes are available by made-to-orders.

## ■ Dimensional drawing

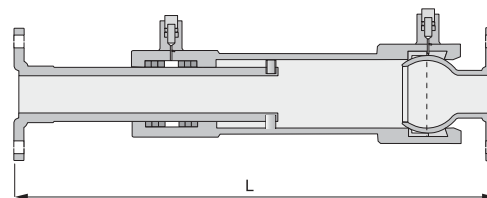

Single Type

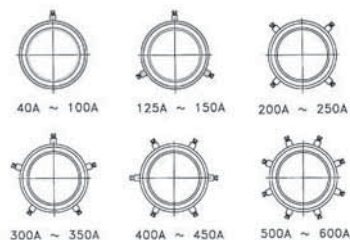

Packing Cylinder Orientation

# UG-1 Underground Slip Joint

As an injection packing type, this product absorbs displacements and is applied for thermal expansion and contraction. Injection packing has been applied.



## ■ Features

- Injection packing type single slip joint.
- Absorb displacements in straight line direction : It can be used for extremely high-temperature fluid.
- Internal & external guide structure has longer life span than other conventional slip joints.
- External guide with outstanding lubrication ensures smooth slip.
- Safe packing injection is available with internal pressure.
- Double-structure product ensures thermal insulation (for underground use).

## ■ Specifications

Applicable fluid		Sat. Steam, Superheat Steam, Oil, Water, Gas
Maximum running pressure		10, 20, 30kg/cm <sup>2</sup> g
Maximum applicable temperature		250° C (Special orders are available for 250° C)
Materials	Body	GB, SUS, STPG, SCPH2, GCD
	Sleeve	GB, SUS, SC49
	Packing	Grafoil (SG NO.800)

## ■ Dimension (Tr+100 standard)

Size	L (Single)	L (Double)	H
32(1¼")	573	960	67.5 (Insulation thickness+60)
40(1½")	573	960	70 (Insulation thickness+60)
50(2")	573	960	77.5 (Insulation thickness+60)
65(2½")	592	978	87.5 (Insulation thickness+60)
80(3")	608	1,010	92.5 (Insulation thickness+60)
100(4")	639	1,023	105 (Insulation thickness+60)
125(5")	666	1,152	125 (Insulation thickness+60)
150(6")	705	1,153	140 (Insulation thickness+60)
200(8")	705	1,153	165 (Insulation thickness+60)
250(10")	771	1,234	200 (Insulation thickness+60)
300(12")	936	1,260	222.5 (Insulation thickness+60)
350(14")	954	1,296	245 (Insulation thickness+60)
400(16")	987	1,309	280 (Insulation thickness+60)
450(18")	1,159	1,349	620 (Insulation thickness+60)
500(20")	1,166	1,501	337.5 (Insulation thickness+60)
550(22")	1,219	1,519	327.5 (Insulation thickness+60)
600(24")	1,320	1,519	397.5 (Insulation thickness+60)

- ▶ The flanged type and the welding type have the same dimensions.
- ▶ The dimensions above are those for the full open state.
- ▶ These specifications are subject to change for product quality improvements.

## ■ Dimensional drawing

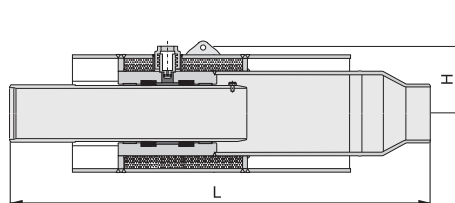

Flanged Type

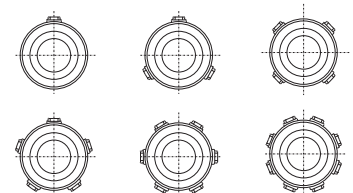

Packing Cylinder Orientation

# Data / Slip Joint

## Standard type and pressure balance type

In case of the standard type, the sleeve operates when a thrust is applied, resulting from the application of internal pressure (P). This thrust force is

$$\text{Effective area X pressure} = \frac{\pi}{4} D^2 \times P$$

The frictional resistance and thrust that is caused by this internal pressure actuates on the pipeline's surrounding. This is why there is a need for a strong anchor that can withstand this frictional resistance. This is not the case for the pressure balance type. Assuming that the external diameter of sleeve ① is  $d_1$ , and that of sleeve ② is  $d_2$ ,

$$\text{Sleeve's left direction effort} = \frac{\pi}{4} d_1^2 P$$

$$\text{Sleeve's right direction effort} = \frac{\pi}{4} (d_2^2 - d_1^2) P$$

$$\text{which is, } \frac{\pi}{4} d_1^2 P = \frac{\pi}{4} (d_2^2 - d_1^2) P$$

$$\text{Or } \frac{\pi}{4} D^2 \times P$$

meaning that there is no thrust caused by internal pressure.

As seen above, the pressure balance type is free from a thrust. Therefore, the load on the anchor is only the frictional resistance of the sleeve.

As such, where a strong anchor cannot be installed due to a concentration of pipelines, a large diameter, or a high pressure level, the use of a pressure balance type would lead to economic advantages, resulting from a reduction in the construction period and anchor installations.

### > Standard type

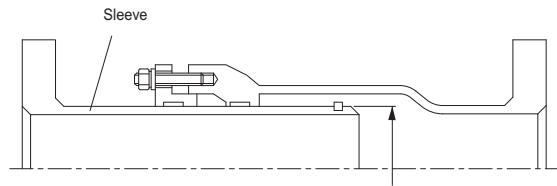

### > Pressure balance type

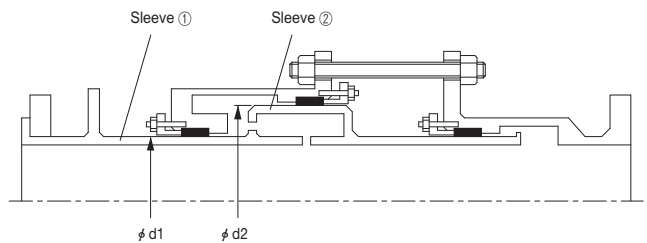

## Calculation of a pipeline's expansion/contraction length

$$\Delta f = \beta \times \Delta t \times f$$

$\Delta f$  = Pipeline's expansion/contraction length(mm)

$\beta$  = Pipeline's expansion coefficient

Steel pipe :  $12.2 \times 10^{-3} \text{mm/m}^\circ \text{C}$

Copper pipe :  $17.7 \times 10^{-3} \text{mm/m}^\circ \text{C}$

Stainless pipe :  $18.4 \times 10^{-3} \text{mm/m}^\circ \text{C}$

$\Delta t$  = Temperature difference ( $^\circ \text{C}$ )

$f$  = Pipeline length (m)

Notes) The expansion/contraction length per 1 m of a pipeline can be calculated by Diagram 1 on page 126 as well.

## Load on anchor

Load on main anchor in straight pipeline section  $F_m (N) = A_e \times P + u$

Load on intermediate anchor in straight pipeline section  $F_i (N) = u$

In terms of the pressure balance type, however,  $F_m = F_i = u$

$A_e$  = Sleeve's internal pressure area

$P$  = Fluid pressure Mpa

$u$  = Sleeve's frictional resistance

## Anchor installation

When using a slip joint, anchors of sufficient strength should be installed. The installation location and types of anchors are as follows:

### ① Main anchor (Main fixing point)

- The end part of a straight pipeline with a closing plate installed
- A curved pipeline section where the fluid's direction changes
- Where the pipeline changes with the use of a reducer and a slip joint
- Where two slip joints are installed in a pipeline
- Between a main pipeline and a branch pipeline, including a slip joint that is not fixed

### ② Intermediate anchor (Intermediate anchor)

- If two or more slip joints are used between two main anchors, install an intermediate anchor in the middle of each slip joint

# Data / Slip Joint

## ■ Installation of a guide and a pipeline weight support

### 1. Guide

For proper expansion/contraction of a slip joint, there is a need for guides that would smoothly deliver to anchors the strength needed for axial movements and ensure alignment between the slip joint and the pipeline center. Each guide's installation location should be based on the following interval:

The tolerance with the pipeline center is within  $\pm 2\text{mm}$  in case of 125A or smaller, and is within,  $\pm 3\text{mm}$  in case of 150A or larger. The parallelism of the pipeline should be maintained within  $\pm 0.5^\circ$

- L1 : Interval between slip joint and guide no. 1
- L2 : Interval between guide no. 1 and guide no. 2
- L3 : Interval between guide no. 2 and intermediate anchor

The maximum installation interval of each guide can be calculated using the following formula. The maximum value of L3 can be determined by Diagram 4.

$$L1 \leq 4D$$

$$L2 \leq 14D$$

$$L3 \leq \sqrt{\frac{\pi^2 EI}{f F_m}} \quad I = \frac{\pi}{64} (D^4 - d^4)$$

L1, L2, L3 : Guide interval (maximum) (mm)

D : External diameter of pipeline (mm)

d : Inside diameter of pipeline (mm)

E : Young's modulus of the designed temperature of pipeline (N/mm<sup>2</sup>)

Steel pipe 200°C 191 x 103N/mm<sup>2</sup>

Stainless pipe 200°C 183 x 103N/mm<sup>2</sup>

I : Pipeline section 2nd moment (mm<sup>4</sup>)

f : Safety factor (3 or more)

F<sub>m</sub> : Load on main anchor (N)

### 2. Pipeline weight support

There is a need for a roller support or a roller hanger guide to prevent the bending of a pipeline that results from the pipeline's weight or fluid mass.

#### ➤ Installation interval of guide

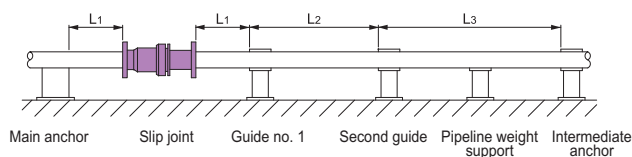

#### ➤ Vertical pipeline

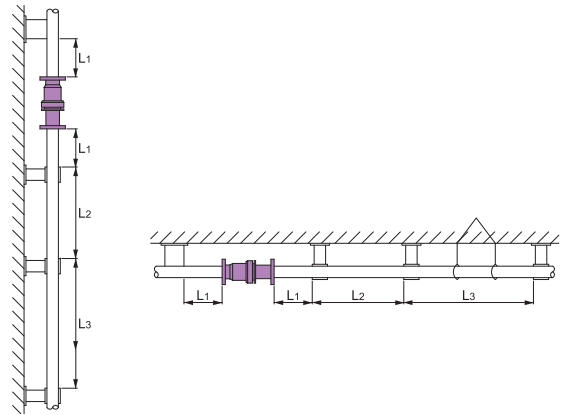

#### ➤ Maximum interval of intermediate guide (10<sup>3</sup> mm)

ks=spps(ks D)

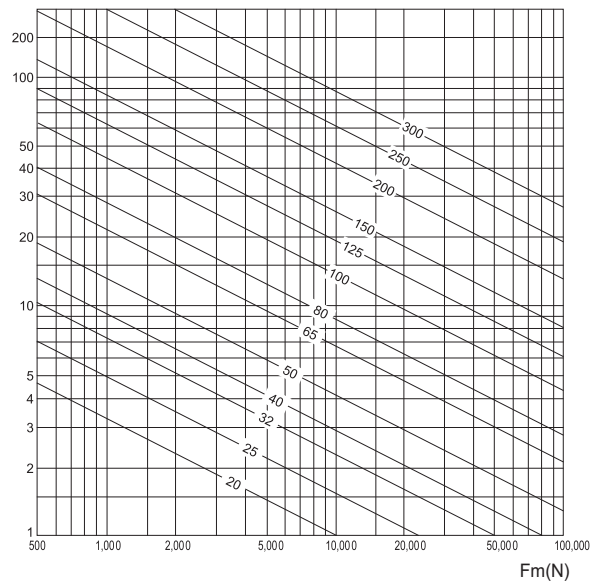

#### ➤ Anchor, guide (example)

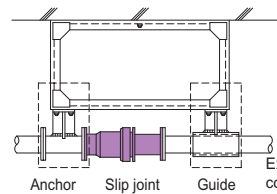

#### ➤ Buckling prevention guide (example)

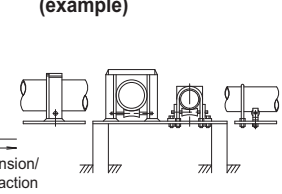

## ■ Example of use of slip joint

#### ➤ Absorption of thermal expansion

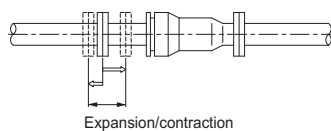

#### ➤ Measure against ground subsidence

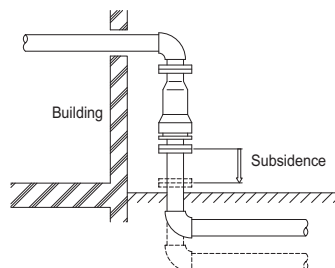

#### ➤ Measure against ground subsidence and earthquakes between buildings

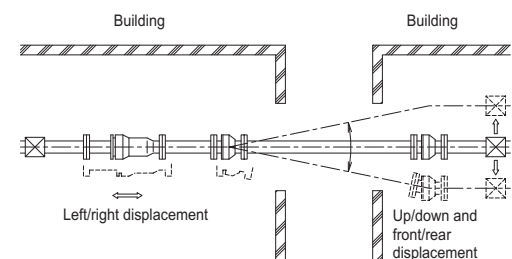

# Data / Ball Joint for Seismic Isolation

## ■ Ball joint equipment for seismic isolation (Single)

This is a seismic isolation piping system that has set up equipment for pipelines, slide guides, and supports between ball joints.

### ● Features

- The use of a ball joint for seismic isolation allows a small device installation space.
- By equipping the pipelines surrounding a ball joint, the construction period and costs are reduced.

#### » Equipping example

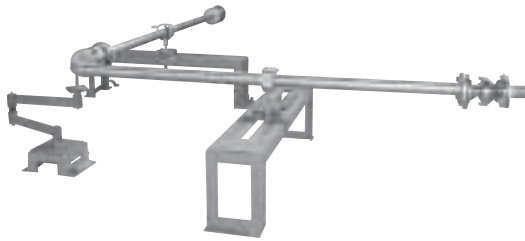

#### » Dimensional drawing

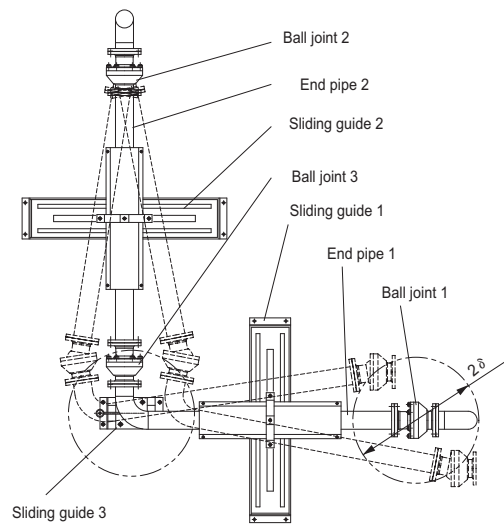

### ● Specifications

Standard	40 ~ 250
Applicable fluid	Cold/hot water, steam, air, gas, oil
Maximum running pressure	10K, 20K
Maximum displacement (θ)	400, 500, 600, 700mm

## ■ Ball joint equipment for seismic isolation (Double)

This is a double type ball joint that has two ball parts on its body.

### ● Features

- Thanks to its large displacement absorption capacity, the distance between ball joints can be reduced. In addition, only a small installation space is required.
- A seismic isolation equipment combined with a slip joint can be installed horizontally in a pipeline. It can be installed vertically and horizontally in a pipeline, even in limited space.

#### » Dimensional drawing

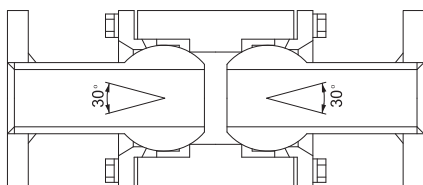

#### » Ball joint equipment for seismic isolation (Double)

This is a seismic isolation equipment that has been combined with a slip joint.

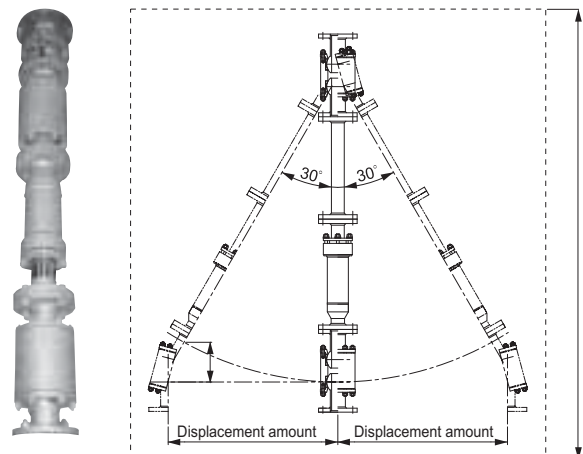

### ● Specifications

Standard	40 ~ 150
Applicable fluid	Cold/hot water, steam, air, gas, oil
Maximum running pressure	10K
Fluid temperature	220°C or below
Maximum displacement	60°
Hydro-pressure test	15K (Water pressure)
End connection	KS 10K FF (Flange)

# Data / Ball Joint Installation Location

A ball joint can be installed in all places where the extraction/contraction of a pipeline can be absorbed. In case of absorption of axial displacement, installation of a ball joint in a bent area of a pipeline or vertically ascending/descending areas is easy even with limited space.

## ■ When two ball joints are used

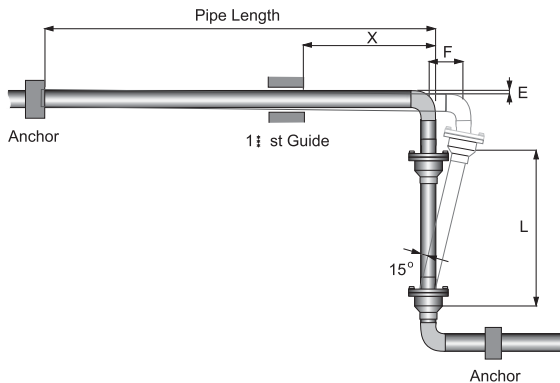

What is the most important here is the location of the first guide and the distance between ball joints.

### 1. Pipeline deflection level (E)

Because a ball joint rotates, once it begins to move as a result of expansion/contraction, a pipeline deflects in the direction of the ball joint installation point.

The deflection level is determined by the expansion/contraction length, and plays an important role in deciding the installation distance of the first guide. In general, a pipeline's deflection level (E) is calculated as follows:

$$E = L - \sqrt{L^2 - \left(\frac{F}{2}\right)^2}$$

Here,

E : Pipeline deflection level (mm)

L : Distance between ball joints (mm)

F : Pipeline's expansion/contraction length (mm)

### 2. Determining the distance between ball joints

Ball joints should be installed based on at least a minimum distance required to absorb the expansion/contraction of a pipeline. The distance between ball joints (L) is calculated as follows:

$$L \geq \frac{F \times 1.5}{\sin \theta} = 6 \times F$$

Here,

L : Distance between ball joints

F : Pipeline's expansion/contraction length

$\theta$  : Ball joint operation angle

1.5 : Safety factor

### 3. Distance to guide no. 1 (X)

Because a ball joint rotates, once it begins to move as a result of expansion/contraction, a pipeline deflects in the direction of the ball joint installation point.

The deflection level is determined by the expansion/contraction length, and the distance to guide no. 1 can be calculated based on the following formula:

$$X = \sqrt{\frac{3 \times Y \times E \times F}{2 \times \delta}}$$

Here,

X : Distance to guide no. 1 (mm)

Y : Young' Midulus (mm)

E : Pipeline deflection level (mm)

F : Pipeline expansion/contraction length (mm)

$\delta$  : Allowable stress of pipeline (kgf/mm<sup>2</sup>)

# Data / Ball Joint

## ■ When three ball joints are used

Using a combination of three ball joints is more effective than using two ball joints. It is an extremely suitable installation method in case there is insufficient installation space or it is difficult to maintain the distance to guide no. 1 because the pipeline deflection level is substantial.

### 1. One-directional pipeline expansion/contraction

Using three ball joints enables efficient absorption of flexural or bending stress. The installation distances among ball joints remain the same as those of two ball joints.

### 2. Two-directional pipeline expansion/contraction

Three ball joints are also used when absorbing a pipeline's two-directional expansion/contraction.

The distance between ball joints is determined based on  $l_1=l_2$ , using the longer expansion/contraction length between  $\delta_1$  and  $\delta_2$ .

Here,  $\theta_1+\theta_2$  should be restricted to the allowed displacement angle ( $\theta/2$ ) range.

► Diagram 2

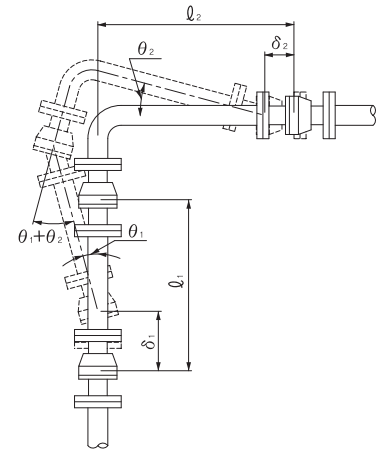

## ■ Installation of anchor and guide no. 1

- Ⓐ Anchors should be installed at the bifurcation point of a pipeline's expansion/contraction length and the two ends of the pipeline.
- Ⓑ Guide no. 1 should be installed as closely as possible to the ball joint. Observe the instructions on the previous page in case two ball joints are used.
- Ⓒ Use the following formula to calculate the load on the anchors and guide no. 1, and install them with sufficient strength to withstand the load.

$$F_1 = \frac{2T}{R} \times 1000$$

$$F_2 = \frac{3EIY}{X^3}$$

$$F_T = \sqrt{F_1^2 + F_2^2}$$

$$F_z = \sqrt{F_A^2 + F_B^2 - 2F_A F_B \cos \alpha}$$

$$F_z = \sqrt{F_A^2 + F_B^2} \text{ (In case of } \alpha=90^\circ \text{)}$$

$F_1$  : Load on guide no. 1 when anchors and three ball joints are used (N) (Refer to Table 1)

$F_2$  : Load on guide no. 1 when two ball joints are used (N) (Refer to Table 2)

$F_T, F_z$  : Combined load of anchors (N)

$F_A$  : Axial load of pipeline A (N) (Refer to Diagram 7)

$F_B$  : Axial load of pipeline B (N) (Refer to Diagram 7)

$\alpha$  : Reflection angle of pipelines A and B (deg.)

$l$  : Distance between ball joints

$T$  : Torque of ball joint (N.m)

$I$  : Moment of inertia

$$I = \frac{\pi}{64} (D^4 - d^4)$$

$D$  : External diameter of pipeline

$d$  : Inside diameter of pipeline

$E$  : Young's modulus

191 x 103 N/mm<sup>2</sup> in case of a steel pipe of 200° C

$X$  : Distance to guide no. 1

$Y$  : Pipeline flexure

► Diagram 3

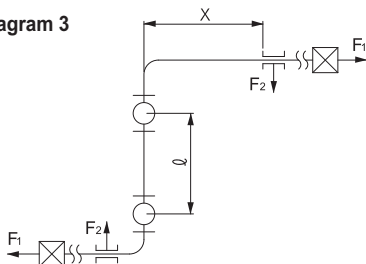

► Diagram 4

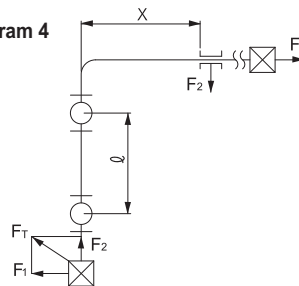

► Diagram 5

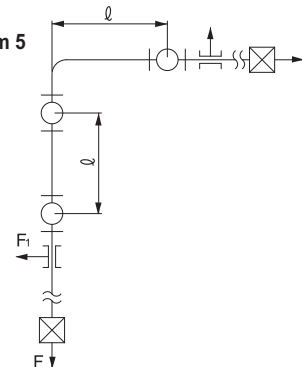

► Diagram 6

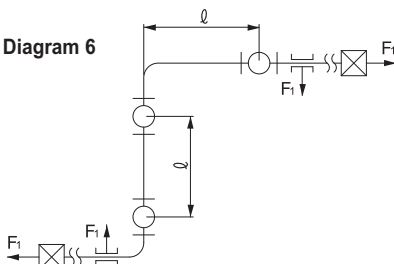

► Diagram 7

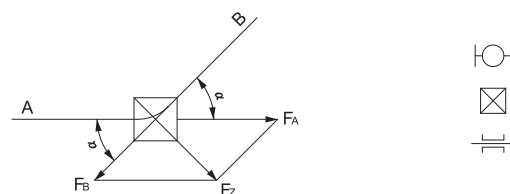

# Data / Ball Joint

## ■ Example of pipeline application

- In case of a horizontal pipeline

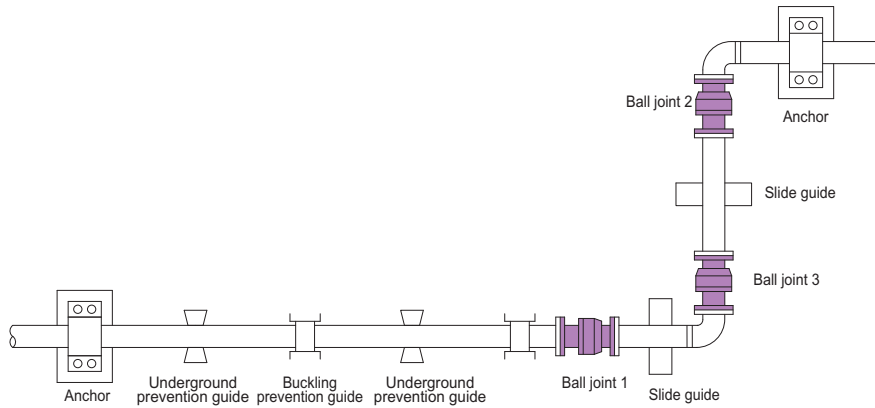

- Example of guide for buckling prevention

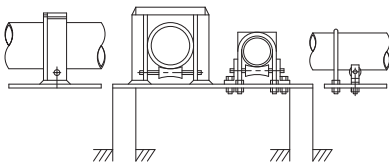

- In case of a vertical pipeline

Install a slide guide in a vertical or a horizontal pipeline so that ball joint ② does not sway according to the slide direction.

## ■ Guide

### 1. Guide for buckling prevention

For a pipeline to expand/contract properly, guides need to be installed to prevent buckling and to provide support for pipeline weight. The installation interval for buckling prevention guides is calculated based on the following formula:

$$L = \sqrt{\frac{\pi^2 EI}{fF}}$$

- L : Pipeline interval (mm)
- F : Pipeline's axial load (N)
- E : Pipeline's Young's modulus (N/mm<sup>2</sup>)
- I : Pipeline's geometrical moment of inertia (mm<sup>4</sup>)
- f : Safety factor (3 or more)

### 2. Pipeline weight support

A pipeline can bend due to its own weight or fluid mass. Guides, such as a roller and a hanger, are installed to prevent bending. Because a pipeline between ball joints moves in the lateral direction, a slide guide needs to be installed.

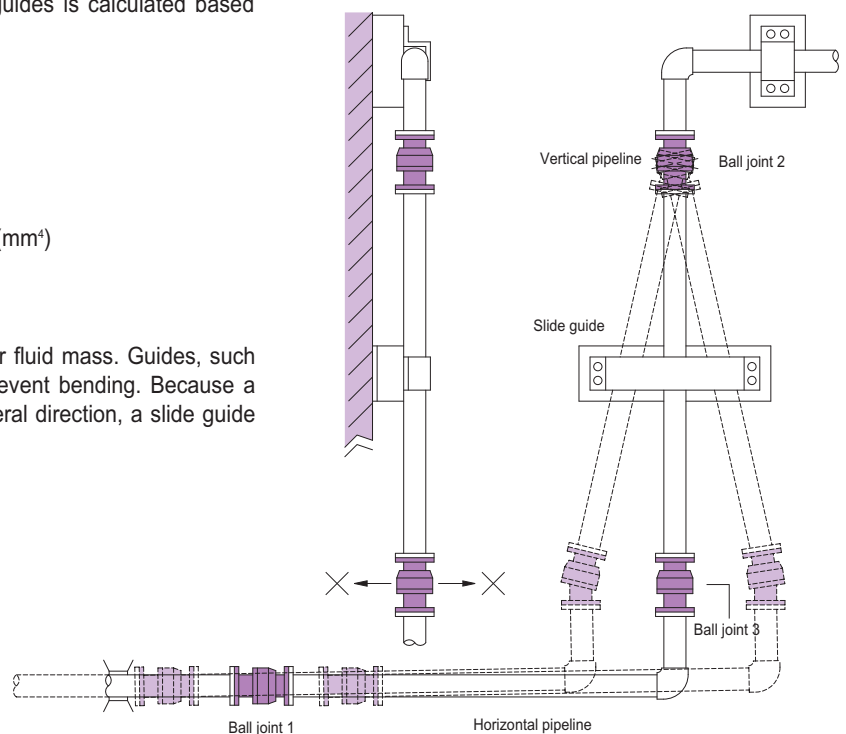

# Data / Ball Joint

## ■ Example of use of three ball joints in a seismic isolation building

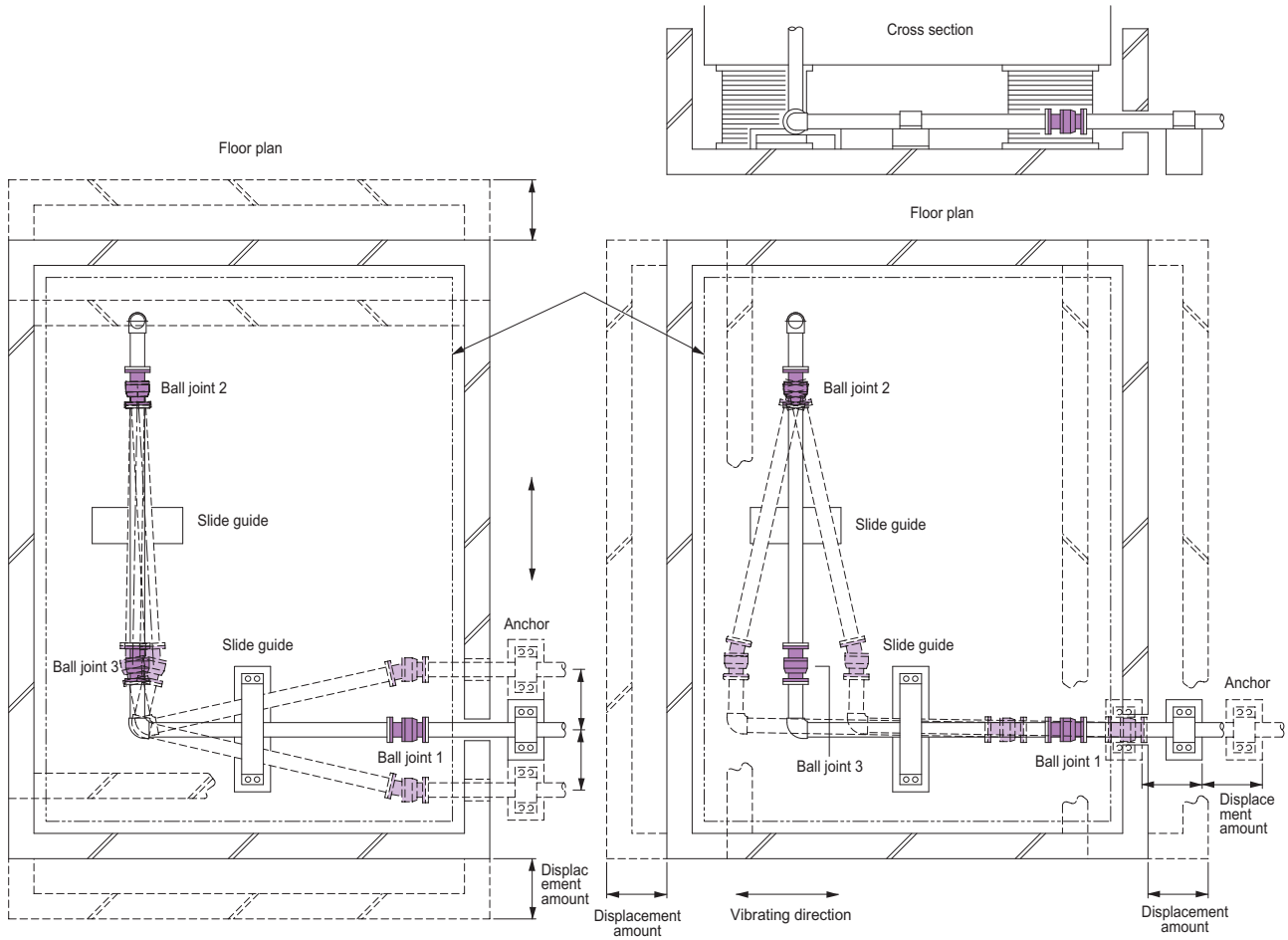

## ■ F1 when pressure is 10K

(N)

Pipe diameter	Distance between ball joints $l$ (mm)					
	1000	1500	2000	2500	3000	3500
50	400	270				
65	600	400				
80	800	540	400			
100	1400	940	700			
125		1200	900	720		
150		1740	1300	1040		
200		3200	2400	1920	1600	
250			4000	3200	2670	2000
300			6000	4800	4000	3000

## ■ F2 when $Y$ equals 1 mm

(N)

Pipe diameter	Distance of guide no. 1 $\times$ (mm)						
	1000	2000	3000	4000	5000	6000	7000
50	170	21	6.1	2.6			
65	430	54	16	6.8			
80	740	93	28	12			
100		220	65	28	14		
125		450	140	56	29		
150		810	240	110	52	30	
200			630	270	140	79	50
250			1360	580	300	170	110
300			2560	1080	560	320	210

Based on the condition of SPSS Sch. 40

# Data / Ball Joint

## ■ Packing

### ● Grand Packing

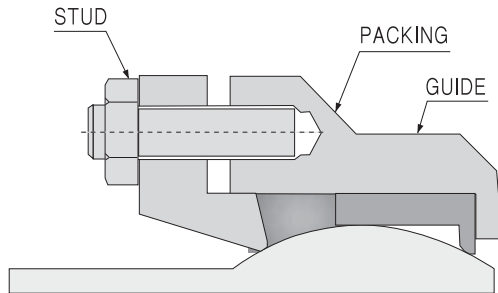

#### 1. SG NO. 100

As a packing used for air, water, and wet steam, its maximum running pressure is 20 kg/cm<sup>2</sup>, and maximum applicable temperature is 200° C. It consists of a composition of Teflon and graphite.

#### 2. SG NO. 200

As a packing used for air, water, and wet steam, its maximum running pressure is 30 kg/cm<sup>2</sup>, and maximum applicable temperature is 250° C. It consists of such materials as non-asbestos fiber, Teflon, and flake graphite.

#### 3. SSG NO. 300

As a packing used for dried saturated steam and superheated steam, its maximum running pressure is 40 kg/cm<sup>2</sup>, and it is mainly used for high temperatures of at least 250° C.

It consists of non-asbestos fiber and flake graphite.

### ● Injection packing

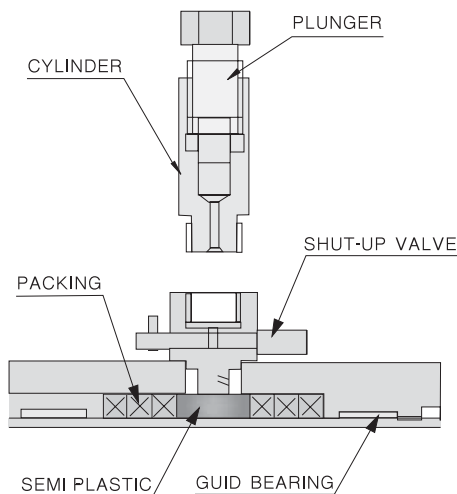

#### 1. SI NO. 700

As a packing used for air, water, and steam, its maximum use pressure is 20 kg/cm<sup>2</sup>, and could be used up to maximum use temperature of 200° C. The left and right packings are made of zeolite fiber and high-density graphite, and NO.53 Semi-Plastic is used for the inserted packing.

#### 2. SI NO.800

As a packing used for air, water, and steam, its maximum running pressure is 20 kg/cm<sup>2</sup>.

The packings on the right and the left consist of non-asbestos fiber for high temperature and high-density graphite, and No. 55 semi-plastic is used for injection packing.

#### 3. SI No. 900

As a packing mainly used for superheated steam, its maximum running pressure is 40 kg/cm<sup>2</sup>, and maximum applicable temperature is 450° C.

The packings on the right and the left consist of non-asbestos fiber for high temperature and high-density graphite, and No. 60 semi-plastic is used for injection packing.

## ■ What is a super packing?

Super packing has been developed to ensure outstanding sealing performance and a stable life span. It is a packing that combined, based on a transparent ratio, the expansion sides with special oil and other inorganic substances. Super packing offers superb performance in its thermal resistance range from -200° C to 450° C as well as its internal characteristics, internal size, and internal mechanism.





# Hammerless Check Valve / Foot Valve

## 9

### Hammerless Check Valve / Foot Valve



Used to prevent the backward flow of fluid in the pump outlet side, this valve prevents water hammers, protects pump pipelines, and functions as a bypass valve.

#### Hammerless check valve

Type	Size	Applicable fluid	Applicable pressure (kgf/cm <sup>2</sup> g)	Materials		End connection	Page
				Body	Disc, seat		
YHL-100	40(1½")~500(20")	Water	Maximum 14	GC200	NBR, BC6	KS 10K RF FLANGE	154
YHL-200	50(2")~500(20")		Maximum 20	GCD450, SCPH2		KS 20K RF FLANGE	

#### Foot valve

Type	Size	Applicable fluid	Applicable pressure (kgf/cm <sup>2</sup> g)	Materials		End connection	Page
				Body	Disc/Seat		
YFV-1	40(1½")~250(10")	Water	Maximum 14	GC200	NBR, BC6	KS 10K RF FLANGE	157

# Type YHL-100, 200 Hammerless Check Valve

This product is used to prevent fluid from flowing backwards into a hammerless check valve pump outlet.

It prevents water hammers, protects pump pipelines, and also functions as a bypass valve.



Type YHL-100



Type YHL-200

## ■ Features

- Water Hammer free.  
Prevent Water Hammer :  
The valve closes when fluid inside the pipeline becomes a speed of stoppage, based on precise movements of the spring & built-in buffer (a part inside the valve that resembles an umbrella playing an essential role in preventing Water Hammer).
- Suitable for pumps, pipelines protection & environmental preservation :  
Heavy noise & pressure loss, this is the most ideal valve for high-rise apartment buildings and other types of high-rise buildings, underground shopping malls, public office buildings, and other public buildings with little Water Hammer shock.
- Breakdown-free simple structure.
- One-year warranty if there is malfunction.
- Bypass valve function.
- Withdraw water inside pipeline on pump outlet side as bypass valve & replenishes guiding water when vacuum establishes on pump inlet side.

## ■ Specifications

Type		YHL-100	YHL-200
Maximum running pressure		Maximum 14kgf/cm <sup>2</sup> g	Maximum 20kgf/cm <sup>2</sup> g
Applicable fluid		Water	
Fluid temperature		5~80° C	
Leakage allowance		0	
End connection		KS 10K RF FLANGE	KS 20K RF FLANGE
Materials	Body	GC200	GCD450, SCPH2
	Disc, seat	NBR, BC6	
Hydraulic test pressure		20kgf/cm <sup>2</sup> g	30kgf/cm <sup>2</sup> g

▶ Valves for hot water and other fluid are also available by made-to-orders.

## ■ Dimensions

Size	E	H1	H2	Weight (kg)
40(1½")	120	95	162	7.3
50(2")	135	100	183	9.3(15.8)
65(2½")	145	100	200(196)	11.2(19)
80(3")	150	110	210	15(25.5)
100(4")	160	120	217	20(31)
125(5")	190	125	255(259)	31(52.7)
150(6")	200	135	280(284)	40(68)
200(8")	235	210	416(424)	80(136)
250(10")	275	260	560(568)	92(160)
300(12")	340	402	622	126.3(215)
350(14")	370	488	834	168(290)
400(16")	415	582	932(970)	212.3(361)

▶ Dimensions in the parentheses are for YHL-200.

## ■ Dimensional drawing

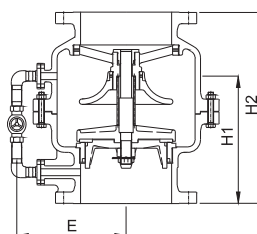

Size of 40 to 50

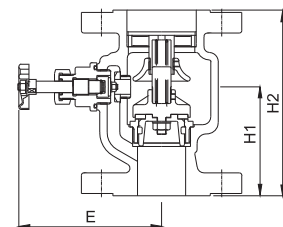

Size of 300 to 400

Types YHL-100, 200

# Type YHL-100, 200 Hammerless Check Valve

## ■ Pressure loss curve

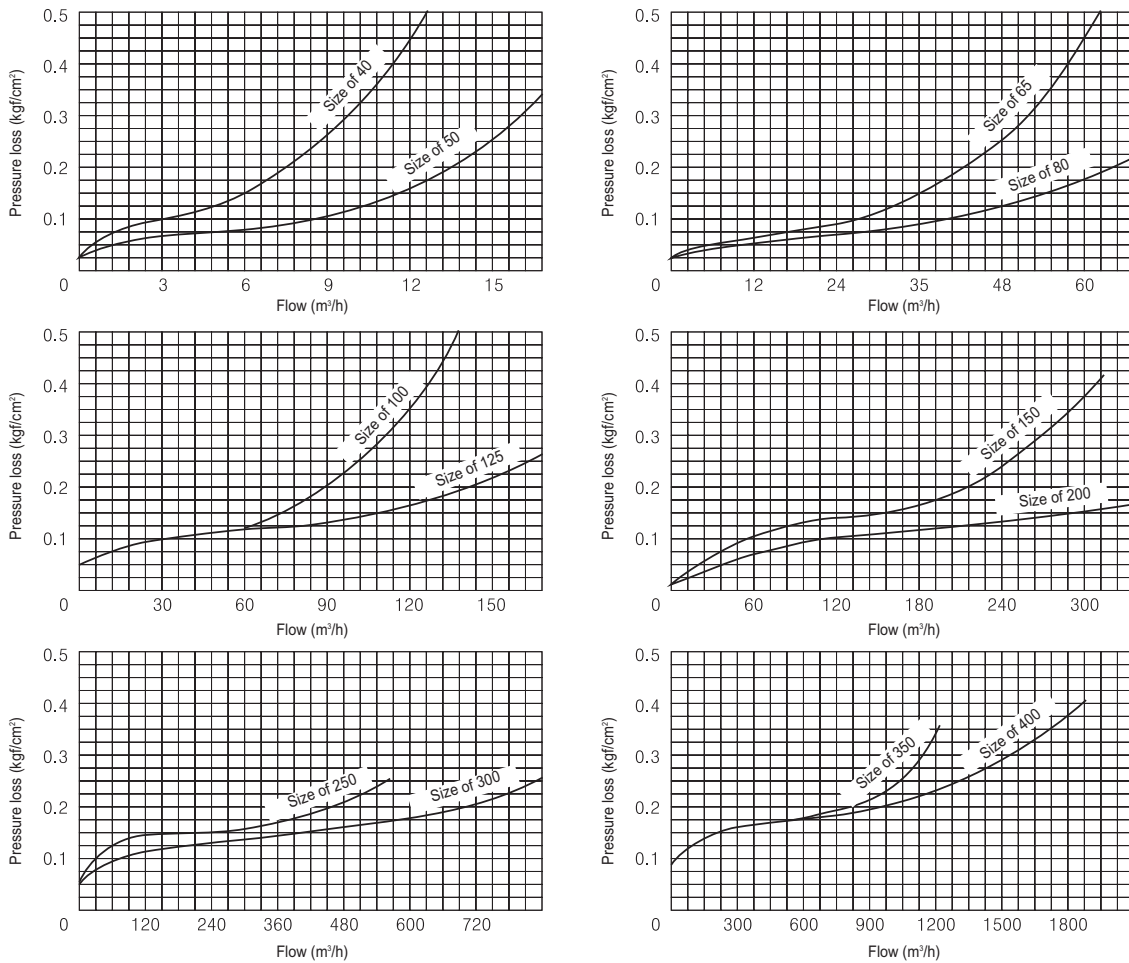

## ■ Water hammer test and pressure increase

The pressure loss and characteristics chart below makes a comparison between the characteristics of Samyang's hammerless check valve and a general swing-type check valve. When tested under the same conditions, the closing time of the hammerless check valve is shorter, and thus there is little surge in pressure

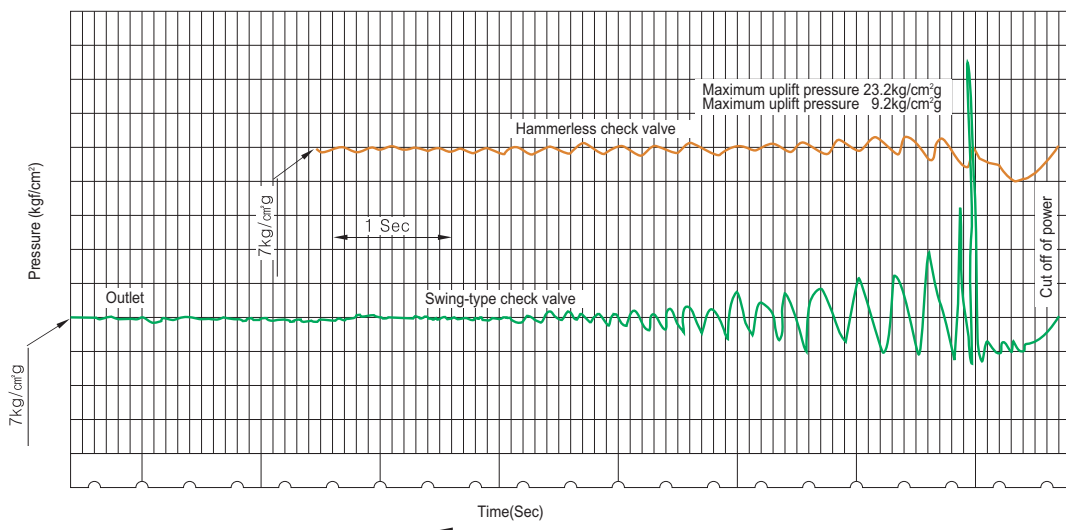

# Type YHL-100, 200 Hammerless Check Valve

## How it works

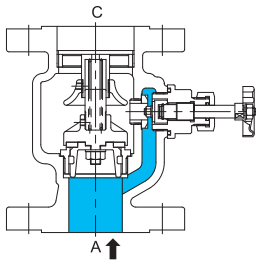

1. When the pump commences operation, the fluid's pressure arrives at side A, as seen in the diagram.

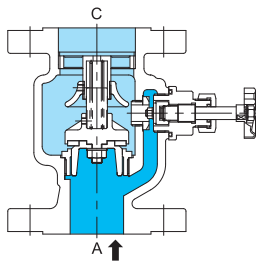

2. The fluid, which reached A, raises the disc even at extremely little pressure (0.1 kgf/cm<sup>2</sup>g), resulting in the fluid passing through.

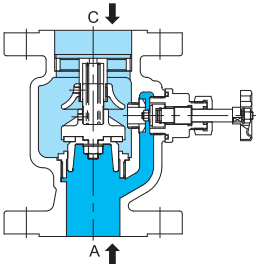

3. Resulting from subtle operation, the disc is completely pushed upwards, as seen in the diagram, even when the pressure is merely 0.3 kgf/cm<sup>2</sup>g. In other words, the disc comes into complete contact with buffer C, enabling the fluid's flow to reach the most satisfactory state.

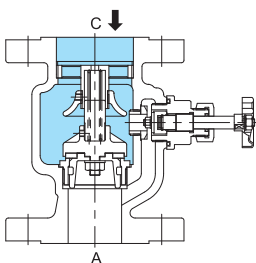

4. When the pump stops operating, the supply pressure drops, and when the supply pressure becomes 0.1 kgf/cm<sup>2</sup>g, the valve has been closed already by the spring's force. As a result, there is no pressure shock or vibration that occurs from the commencement of the backward flow of fluid. This is why there is no water hammer.

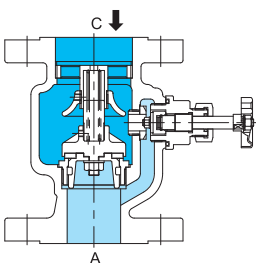

5. The bypass valve installed next to the valve is used to prevent freezing damages by draining water from the pipeline when the pump stops operating, and to replenish the empty pump with water when the pump starts to operate again.

## Cautions for use

1. Leave the bypass valve closed during normal operation. (If the foot valve breaks down, open the valve and replenish the fluid to an appropriate level.)
2. Special attention is needed so that foreign substances, such as sand or welding particles, do not get mixed with the fluid and flow inside the pipeline.
3. If the applicable fluid is different or the valve is intended to be used for high temperatures of 60°C or more, consult with Samyang prior to placing an order.

# Type YFV-1 Foot Valve

When installed on the pump inlet side of an underground water tank, this product is suitable for preventing the backward flow of fluid.



## Specifications

Applicable fluid		Water
Maximum running pressure		Maximum 14kgf/cm <sup>2</sup> g
Fluid temperature		80° C below
Leakage allowance		0
End connection		KS 10K RF FLANGE
Materials	Body	GC200
	Disc, seat	NBR, BC6
	Screen	STS
Hydraulic test pressure		20kgf/cm <sup>2</sup> g

▶ Valves for 20 kgf/cm<sup>2</sup>g are available by made-to-orders.

## Dimensions

Size	E	H1	H2	H3	Weight (kg)
40(1½")	120	95	162	324	9.2
50(2")	135	100	183	366	11.7
65(2½")	145	100	200	400	14.2
80(3")	150	110	210	420	17.8
100(4")	160	120	217	434	23.6
125(5")	190	125	255	510	36.5
150(6")	200	135	280	560	47.3
200(8")	235	210	416	832	88.5
250(10")	275	260	560	1120	106

## Notes for installation in a pump line

- Using the type YHL-1 hammerless check valve, instead of a swing-type valve, on the outlet side of a pump, will prevent a water hammer and protect the pump and pipeline.
- Since the disc of the hammerless check valve and the foot valve is made of NBR, a perfect sealing is maintained. In particular, there is little pressure loss, resulting in less electricity consumption.
- Install a flexible tube on the upper part of the check valve to prevent pipeline vibration resulting from pump vibration.
- The primary pressure control valve (relief valve) maintains a constant pressure level on the pump outlet side, according to the set pressure.
- Install a strainer on the inlet side of the pump to protect facilities in the pipeline and the pump.

## Application Diagram (Example)

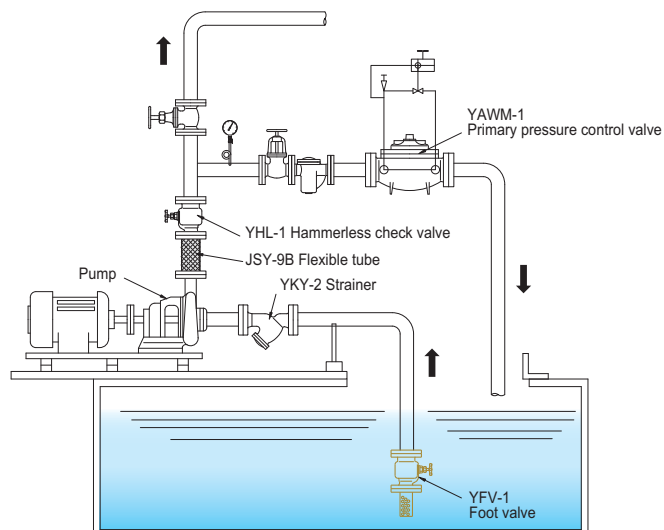

## Dimensional drawing

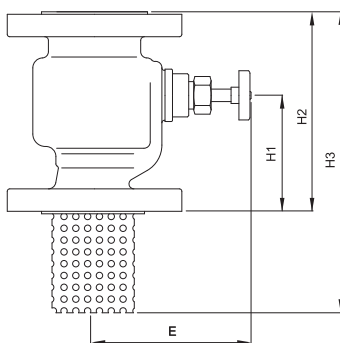



# Air Vent Valve

# 10

## Air Vent Valve



Samyang's air vent valve eliminates air-related problems and prevents pipeline corrosion by automatically discharging air generated in construction facilities' cold/hot water pipelines, water supply and water heating pipelines, as well as plant's cold/hot water pipelines and tanks. In addition, it automatically takes air in when liquid is discharged from pipelines and tanks, thereby ensuring easy discharge by preventing a creation of a vacuum.

### Air vent valve

Type	Size	Applicable fluid	Applicable pressure (kgf/cm <sup>2</sup> g)	Materials		End connection	Page
				Body	Disc, seat		
YAC-3	15(1/2")~25(1")	Water	Maximum 10	C3771	NBR, C3604	KS PT SCREW	160
YAC-3A				BsC3	EPDM, STS		161
YAC-3M				GC200			162
YAC-4							

# Type YAC-3 Air Vent Valve

This is a compact air vent valve that is used for pipelines, hot water boilers, fan coils, and small- to medium-sized pressure tanks. The adoption of the BBC (Bubble Crush) method ensures safe operation and prevents water hammers, hunching, etc.



## ■ Features

- Bubble Crush(BBC) structure prevent Water Hammers & chattering caused by float in special form distributes rising pressure & bubbles.
- Reliable operation is ensured by spring's force seat closing.
- Simple & strong structure.
- Compact & outstanding air discharge performance.
- Manual closing device installed on outlet side.
- Manufacture as air vent valve for steam.

## ■ Specifications

<b>Size</b>		15(1/2"), 20(3/4"), 25(1")
<b>Applicable fluid</b>		Cold / hot water
<b>Applicable pressure</b>		Maximum 10kgf/cm <sup>2</sup> g
<b>Fluid temperature</b>		5~100° C
<b>End connection</b>		KS PT SCREW
<b>Materials</b>	<b>Body</b>	C3771
	<b>Disc, seat</b>	NBR, C3604
<b>Hydraulic test pressure</b>		15kgf/cm <sup>2</sup> g

## ■ Air discharge volume curve

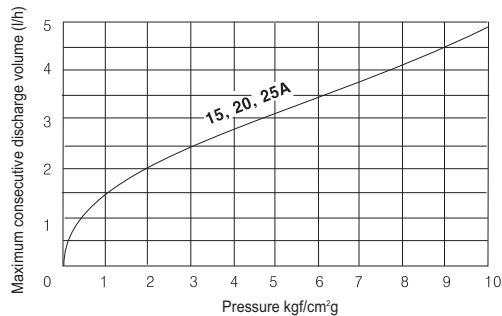

## ■ Air discharge volume curve

### When discharging air

It discharges air that comes in when the seat is opened by the float's own weight.

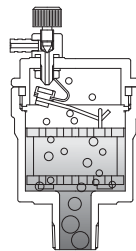

### When discharge stops

If the water level and float rises immediately after air discharge, the valve closes by the float's buoyancy and spring's elasticity.

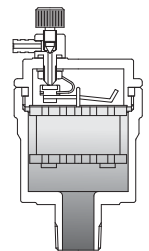

## ■ Dimensional drawing

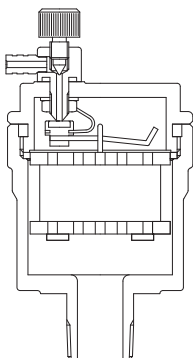

## ■ Installation example and cautions during handling

- When installing the valve in a pipeline, install it within 5° of a vertical line.
- When installing the valve indoors, connect the outlet side to the drainage just in case there is leakage.
- Install a manual valve on the inlet side for repair and inspections.
- Close the manual closing cock if there is a leakage.

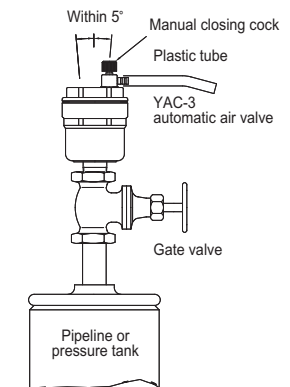

# Type YAC-3A, 3M Automatic Air Vent Valve

As an air vent valve for liquid, it automatically discharges remaining air from pipelines and air from sealed tanks, thereby allowing for smooth flow of fluid.



Type YAC-3A



Type YAC-3M  
Multi-functional air vent valve  
(air vent + strainer + stop valve)

## ■ Features

- Operates smoothly even at low pressure.
- Flexible disc structure for smooth & subtle operation.
- Easy repair & inspections designed.
- Steel ball installation prevents reverse entry of air.

## ■ Specifications

Size	YAC-3A, 3M	
Applicable fluid	Cold / hot water	
Applicable pressure	Maximum 10kgf/cm <sup>2</sup> g	
Fluid temperature	5~80° C	
End connection	KS PT SCREW(Female)	
Materials	Body	BsC3
	Disc, seat	EPDM, STS
Hydraulic test pressure	15kgf/cm <sup>2</sup> g	

## ■ Air discharge volume curve

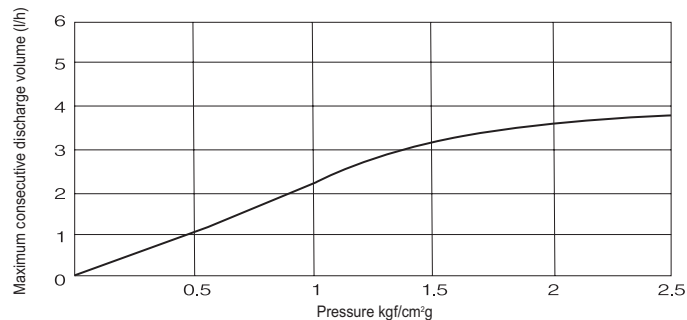

## ■ Dimensions

Type	A	B	C	Weight (kg)
YAC-3A	27	56	103	0.7
YAC-3M	27	56	200	1.7

## ■ Dimensional drawing

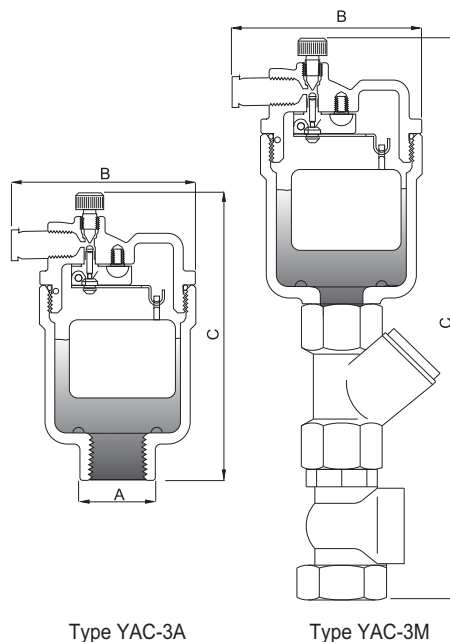

Type YAC-3A

Type YAC-3M

## ■ Installation method and cautionary measures

1. Install it vertically (within 5°).
2. When installing indoors, connect the outlet side to the drainage.
3. Install a manual valve on the inlet side.
4. In case of leakage, close by using the handle.

## ■ Measures in case of leakage

1. In case of leakage, close the manual valve on the lower part of the air vent, open the cap, check if there are any foreign substances on top of the disc or seat, wash the foreign substances away, if any, and then resume normal operation.
2. When reassembling, take caution so that the float is not detached from the press part.



# Type YAC-4 Air Vent Valve

As an air vent valve for liquid, it automatically discharges remaining air from pipelines and air from sealed tanks, thereby allowing for smooth flow of fluid.



## ■ Features

- Large discharge capacity covers up to 10~20 kgf/cm<sup>2</sup>g.
- Flexible disc structure for smooth & subtle operation.
- NBR-based seat features outstanding level of air tightness.
- Easy repair & inspections manufactured.

## ■ Specifications

Type		YAC-4
Applicable fluid		Cold / hot water
Applicable pressure		Maximum 10kgf/cm <sup>2</sup> g
Fluid temperature		5~80° C
End connection		KS PT SCREW
Materials	Body	GC200
	Disc, seat	EPDM, STS
Hydraulic test pressure		15kgf/cm <sup>2</sup> g

## ■ Dimensions

Size	d	A	H	Weight (kg)
15(1/2")	1/2"	115	153	2.0
20(3/4")	3/4"	115	153	2.0
25(1")	1"	115	153	2.2

(mm)

## ■ Dimensional drawing

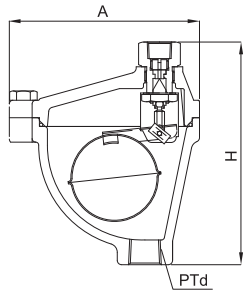

## ■ Air discharge volume curve

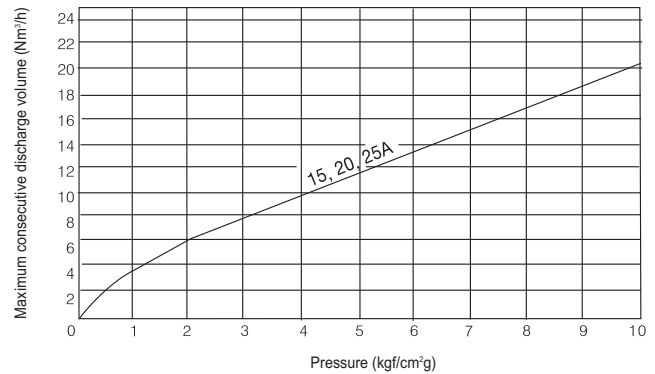

# Intelligent Control Check Valve / Suction Diffuser

# 11

## Intelligent Control Check Valve / Suction Diffuser



### Control check valve

Type	Size	Applicable fluid	Applicable pressure (kgf/cm <sup>2</sup> g)	Materials (Body)	End connection	Page
YCC-1, 1R	50(2")~600(24")	Water, Liquid	Maximum 10	GC200	KS 10K FF FLANGE	164
YCC-2, 2R			Maximum 20	GCD450	KS 20K FF FLANGE	
YCC-3, 3R			Maximum 30	SCPH2	KS 30K FF FLANGE	

### Suction diffuser

Type	Size	Applicable fluid	Applicable pressure (kgf/cm <sup>2</sup> g)	Materials (Body)	End connection	Page
YSD-1, 1R	50(2")~600(24")	Water, Liquid	Maximum 10	GC200	KS 10K FF FLANGE	165
YSD-2, 2R			Maximum 20	GCD450	KS 20K FF FLANGE	
YSD-3, 3R			Maximum 30	SCPH2	KS 30K FF FLANGE	

# Type YCC-1, 2, 3 / 1, 2, 3R Intelligent Control Check Valve

This check valve protects the pump by bypassing the discharge pressure that instantaneously rises when the pump starts.

It also absorbs shock by linearly opening the water hammer cushion valve to prevent a water hammer resulting from a surge in pressure by the backward flow of water inside a standing pipeline when the pump stops.

In addition, this product has a port soft sealing structure, thereby ensuring perfect air tightness at normal times.



Type YCC-1, 2, 3



Type YCC-1, 2, 3R

## ■ Dimensional drawing

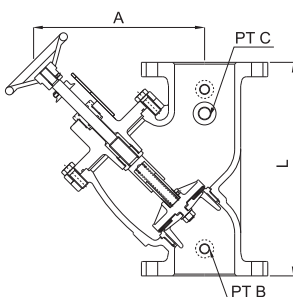

Flanged End Type

## ■ Features

- Performs 5 different functions : check valve, balancing valve, bypass valve, and relief valve.
- No Water Hammer in the pump : The spring reacts to the Pump Discharge Pressure (PDP) so that the disc closes in time.
- No need to install a separate balancing valve & attached indicator enables easy identification : The valve can regulate the flow of fluid according to the accurately controlling valve opening degree and the attached indicator visually provides the open/closed status of the valve.
- Possible to install in any direction, horizontally or vertically : Installation space is reduced and construction is convenient.

## ■ Specifications

Type	YCC-1, 1R	YCC-2, 2R	YCC-3, 3R
Applicable fluid	Water, Liquid		
Applicable pressure	Maximum 10kgf/cm <sup>2</sup> g	Maximum 20kgf/cm <sup>2</sup> g	Maximum 30kgf/cm <sup>2</sup> g
Fluid temperature	Maximum 80° C	Maximum 120° C	Maximum 120° C
End connection	KS 10K FF FLANGED	KS 20K RF FLANGED	KS 30K RF FLANGED
Hydraulic test pressure	15kgf/cm <sup>2</sup>	30kgf/cm <sup>2</sup>	45kgf/cm <sup>2</sup>
Materials	Body	GC200	SCPH2
	Seat	BC6	
	Disc	EPDM	
	Gasket	NBR, EPDM	NBR, EPDM

## ■ Categorization of types

Category	Main functions
YCC-1, YCC-2, YCC-3	Check, Balancing, Stop valve, By-pass
YCC-1R, YCC-2R, YCC-3R	Check, Balancing, Stop valve, By-pass, Relief + Pressure gauge + Special internal coating

## ■ Dimensions

Size	L		A	PT B	PT C
	10K	20K		By-pass	Relief conn
50(2")	235	235	184	3/8	1/2
65(2 1/2")	270	270	206	3/8	1/2
80(3")	295	295	232	3/8	3/4
100(4")	355	355	278	3/8	3/4
125(5")	420	424	328	1/2	1
150(6")	470	474	372	1/2	1
200(8")	550	558	451	3/4	1 1/4
250(10")	670	678	542	3/4	1 1/2
300(12")	780	788	645	1	2
350(14")	890	902	720	1	2 1/2
400(16")	980	1000	768	1 1/2	3
450(18")	1100	1140	850	1 1/2	3
500(20")	1220	1260	950	2	4
550(22")	-	1360	1060	2	4
600(24")	-	1480	1150	2	6

# Type YSD-1, 2, 3 / 1, 2, 3R Intelligent Suction Diffuser



Type YSD-1, 2, 3



Type YSD-1, 2, 3R

## Dimensional drawing

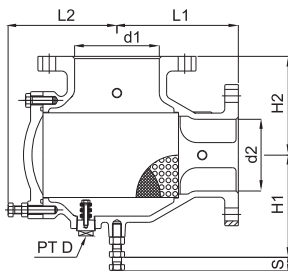

Type Flanged

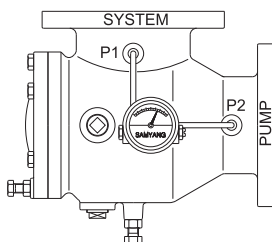

Type Flanged (Standard)

## Features

- Structure to verify whether internal screen need cleaning.
- Quick-changeable hinge structure enable quick cleaning of the screen.
- Built-in magnet protects the pump & pipeline from damage caused by iron content & welding slags.
- Maximized pump efficiency & little pressure loss by outlet side located vane.

## Specifications

Type	YSD-1, 1R	YSD-2, 2R	YSD-3, 3R	
Applicable fluid	Water, Liquid			
Applicable pressure	Maximum 10kgf/cm <sup>2</sup>	Maximum 20kgf/cm <sup>2</sup>	Maximum 30kgf/cm <sup>2</sup>	
Fluid temperature	Maximum 80° C	Maximum 120° C	Maximum 120° C	
End connection	KS 10K FF FLANGED	KS 20K RF FLANGED	KS 30K RF FLANGED	
Materials	Body	GC200	GCD450	
	Screen	STS304		
	Gasket	NBR, EPDM	EPDM	
	Drain plug	SS400, GC200		
Hydraulic test pressure	15 kgf/cm <sup>2</sup>	30 kgf/cm <sup>2</sup>	45 kgf/cm <sup>2</sup>	

## Categorization of types

Category	Main functions
YSD-1, YSD-2, YSD-3	Suction diffuser + Built-in magnet + Pressure loss measuring device (Standard)
YSD-1R, YSD-2R, YSD-3R	Suction diffuser + Intelligent element

## Dimensions

(mm)

Systm (d1)	Pump (d2)	L1	L2	H1	H2	S	PT D
50(2")	50A	113	78	110	78	10	3/8
65(2 1/2")	65A	125	89	115	121	10	3/8
80(3")	80A	144	109	124	140	10	1/2
	65A	144	109	124	140	10	1/2
100(4")	100A	180	164	150	160	12	3/4
	80A	180	164	150	160	12	3/4
	65A	180	164	150	160	12	3/4
125(5")	125A	215	192	175	181	12	1
	100A	180	163	150	160	12	3/4
	80A	180	163	150	160	12	3/4
150(6")	150A	250	224	205	212	14	1
	125A	215	193	175	181	12	1
	100A	215	193	175	181	12	1
250(10")	200A	320	285	260	274	17	1 1/4
	150A	250	223	205	216	14	1
	125A	250	223	205	216	14	1
250(10")	250A	360	330	310	323	18	1 1/4
	200A	320	280	260	274	17	1 1/4
	150A	320	280	260	274	17	1 1/4
300(12")	300A	410	372	360	392	23	1 1/2
	250A	360	332	310	323	18	1 1/4
	200A	360	332	310	323	18	1 1/4
350(14")	350A	480	421	390	421	23	2
	300A	410	372	360	392	23	1 1/2
	250A	360	331	310	323	18	1 1/4
400(16")	400A	560	484	450	471	23	2
	350A	560	484	450	471	23	2
	300A	560	484	450	471	23	2
450(18")	450A	640	550	510	535	28	2
500(20")	500A	710	610	570	590	30	2
550(22")	550A	780	670	625	650	34	2
600(24")	600A	840	720	680	710	40	2

※ Reducing sizes of the outlet side (d2), other than those listed above, are available based on customer request.



# Data / Intelligent Control Check Valve, Suction Diffuser

## ■ Items that become unnecessary or can be saved with control check valve installation

1. Check Valve
2. Gate Valve
3. Balancing Valve
4. Relief Valve
5. Flange
6. Gasket, Bolt, Nut
7. Reduced construction time
8. Reduced labor costs, etc.

## ■ Cautions for installation

1. It can be installed on a horizontal or vertical pipeline.
2. Install a flexible joint to prevent damage to the pipeline resulting from pump vibration.
3. Install after checking the direction of the fluid's flow (arrow).
4. Use a spanner or the handle to open the valve and operate the pump.
5. If there is a bypass valve attached, operate after closing the external ball valve.

## ■ Information required when placing an order

1. Model
2. Type of fluid
3. Maximum running pressure (kgf/cm<sup>2</sup>g)
4. Maximum temperature used (°C)
5. Pump's discharge pipeline diameter (mm)
6. Maximum flow (m<sup>3</sup>/hr or LPM)
7. Other options

## ■ Items that become unnecessary or can be saved with suction diffuser installation

1. Reduced pipe on the inlet side
2. Reducing elbow
3. Strainer
4. Flange (2 each)
5. Gasket, bolt, nut
6. Pipe support
7. Reduced labor costs
8. Reduced construction time

## ■ Test operation tips

1. The valve is in a closed state when delivered to the customer. (Indicator says 0%)
2. After installation, open the valve by loosening the square part of the stem that protrudes towards the cover part or the handle towards the left (counterclockwise direction)
3. The opening degree can be checked through the indicator that is attached to the cover.
4. It is recommended to maintain the opening degree at 100%. Controlling the pump's discharge amount by adjusting the opening degree leads to pump overload. This is why the opening degree should not be adjusted unless in special cases.
5. Install a pressure gauge on the outlet side of the valve to check for leakage. (If the outlet pressure drops when the pump is not in operation or the fluid is not flowing, it means that there is leakage.)

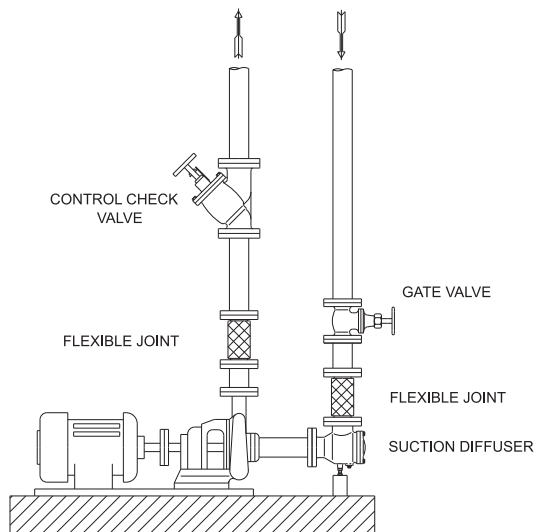
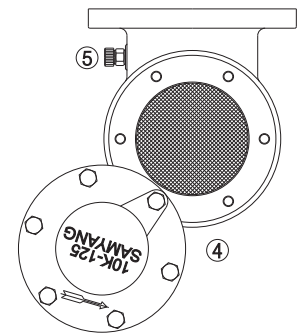
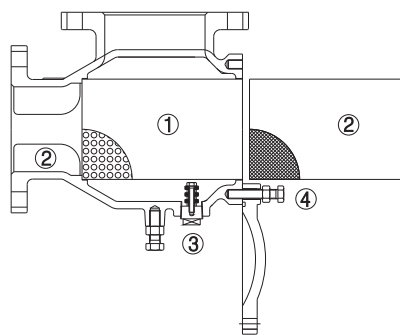

Piping method using control check valves

## ■ How to clean the screen and remove the wire and wire mesh net

1. Sufficiently flush the inside of the pipeline after opening all valves.
2. Close the gate valve in front of the suction diffuser.
3. Open the drain plug ③ in the lower part of the main body to completely withdraw water and remove foreign substances.
4. Disassemble the bolts on the cover and open the cover by turning it based on the hinge ④.
5. Open the screen ① simultaneously.
6. Remove the wire mesh net ② located outside the screen.
7. Clean the screen ①, and assemble in reverse order.

# Reference Data

# 12

## Reference Data



Category		Page
Engineering unit conversion table		168
Saturated steam table		171
Superheated steam table		172
Fluid viscosity		173
Vapor viscosity table		174
Liquid viscosity table		176
Nominal diameter selection	Method based on Cv formula	178
	Unit flow table (Water) / Cv value	179
	Unit flow table (Saturated steam) / Cv value	180
	Unit flow table (Air) / Cv value	181
Flow velocity within pipeline		182
Pipeline head loss		184
Generated condensate volume of steam pipeline		185
Dimensions table of carbon steel pipe		186
Pressure stage table of iron/steel pipe flange		
Standard dimensions of flange		187



# Data / Engineering Unit Conversion Table

## Length

cm	m	km	in	ft	Cheok (Korean foot)
1	0.01	0.01	0.3937	0.0328	0.033
100	1	0.001	39.371	3.2809	3.3
100,000	1,000	1	39,371	3,280.9	3,300
2.54	0.02540	0.0254	1	0.08333	0.08382
30.48	0.3048	0.3048	12	1	1.0058
30.30	0.30303	0.30303	11.9303	0.9942	1

## Area

cm <sup>2</sup>	m <sup>2</sup>	in <sup>2</sup>	ft <sup>2</sup>	Cheok <sup>2</sup> (Korean foot)
1	0.001	0.1550	0.001076	0.001089
1 × 10 <sup>4</sup>	1	1,550.1	10.7643	10.89
6.4514	0.006451	1	0.006944	0.007026
929	0.0929	144	1	1.0117
918.27	0.09183	142.34	0.9885	1

## Volume

dm <sup>3</sup>	m <sup>3</sup>	ft <sup>3</sup>	Gal (British)	Gal (U.S)	Seok	Cheok <sup>3</sup> (Korean foot)
1	0.001	0.03532	0.220	0.2642	0.025544	0.03594
1,000	1	35.317	219.95	264.19	5.5435	35.937
28.315	0.02832	1	6.2279	7.4806	0.1570	1.0175
4,5465	0.04547	0.1606	1	1.2011	0.02520	0.1633
3.7852	0.03785	0.1337	0.8325	1	0.02098	0.1360
180.39	0.18039	6.3707	39.676	47.656	1	6.4827
27.826	0.02783	0.9827	6.1203	7.3514	0.15425	1

## Mass

g	kg	t (tonne)	lb	Ton (British)	Ton (U.S)	Gwan (3,75 kg)	Geun (0,6 kg)
1	0.001	0.001	0.002205	0.000984	0.001102	0.002267	0.001667
1,000	1	0.001	2.2046	0.000984	0.001102	0.2667	1.6667
1 × 10 <sup>6</sup>	1,000	1	2,204.6	0.9842	1.1023	266.67	1,666.7
453.6	0.4536	0.04536	1	0.0446	0.051	0.121	0.760
1,016,047	1,016.05	1.01605	2,240	1	1.12	270.94	1,693.4
907,185	907.185	0.90719	2,000	0.89286	1	241.91	1,519.8
3,750	3.75	0.00375	8.2673	0.003691	0.004134	1	6.25
600	0.6	0.006	1.3228	0.005905	0.006613	0.16	1

## Viscosity

Poise=g/cm · s (CGS unit)	centipoise. cP	kg/m · s	kg/m · h	lb/ft · s
1	100	0.1	360	0.0672
0.01	1	0.001	3.6	0.000672
10	1,000	1	3,600	0.672
0.00278	0.278	0.00278	1	0.000187
14.88	1,488	1.488	5,356.8	1

## Velocity

m/s	m/h	km/h	ft/s	ft/min	mile/h
1	3,600	3.6	3.281	196.85	2.2370
0.002778	1	0.001	0.009114	0.05468	0.006214
0.2778	1,000	1	0.9114	54.682	0.6214
0.3048	1,097.25	1.0973	1	60	0.68182
0.005080	18.287	0.01829	0.01667	1	0.01136
0.4470	1,609.31	1.6093	1.4667	88	1

# Data / Engineering Unit Conversion Table

## Flow

ℓ / s	m <sup>3</sup> /h	m <sup>3</sup> / s	Gal/min (British)	Gal/min (U,S)	ft <sup>3</sup> /h	ft <sup>3</sup> /s
1	3.6	0.001	13.197	15.8514	127.14	0.03532
0.2778	1	0.002778	3.6658	4.4032	35.317	0.009801
1,000	3,600	1	13,197	15,851	127,150	35.3165
0.075775	0.27279	0.0475775	1	1.2011	9.6342	0.02676
0.06309	0.2271	0.046304	0.8325	1	8.0208	0.02228
0.027865	0.02832	0.057865	0.1038	0.1247	1	0.002778
28.3153	101.935	0.02832	373.672	448.833	3,600	1

## Pressure

kPa	MPa	kgf/cm <sup>2</sup>	lb /in <sup>2</sup>	atm	mHg	inHg	mH <sub>2</sub> O (mAq)	inH <sub>2</sub> O (inAq)
1	0.001	0.010197	0.14504	0.009869	0.007501	0.29530	0.10197	4.01463
100	0.1	1.0197	14.50	0.9869	0.7500	29.55	10.21	401.8
98.0665	0.098067	1	14.223	0.9678	0.7355	28.96	10.01	394.0
6.8948	0.006895	0.07031	1	0.06804	0.05171	2.0355	0.7037	27.70
101.325	0.101325	1.0333	14.70	1	0.760	29.92	10.34	407.2
133.322	0.133322	1.3596	19.34	1.316	1	39.37	13.61	535.67
3.3864	0.003386	0.03453	0.4912	0.03342	0.02540	1	0.3456	13.61
9.8067	0.009807	0.09991	1.421	0.0967	0.07349	2.893	1	39.37
0.24909	0.000249	0.002538	0.03609	0.002456	0.001867	0.07349	0.0254	1

## Stress

Pa	MPa or N/mm <sup>2</sup>	kg/mm <sup>2</sup>	kgf/cm <sup>2</sup>
1	0.000001	0.06101972	0.04101972
1,000,000	1	0.101972	10.1972
9,806,650	9.80655	1	100
98,066.5	0.0980665	0.01	1

## Power

N	dyn	kgf	lbf
1	100,000	0.101972	0.22480894
0.00001	1	0.05101972	0.0522480894
9.80665	980,665	1	2.2046226
4.4482216	444,822.16	0.45359237	1

## Work / Energy / Calorie

J	kw · h	kgf · m	kcal
1	0.06277778	0.101972	0.000238889
3,600,000	1	367,098	860
9,80665	0.00272407	1	0.00234270
4,186.05	0.00116279	426.858	1



# Data / Engineering Unit Conversion Table

## ■ Comparison between SI units and conventionally used units

Measurement	SI unit	Units jointly used with SI units	Conventionally used units	SI unit conversion rate	Notes
Plane angle	rad	° Degree		—	1° = (π / 180)rad 1' = (1/60)° 1" = (1/60)'
		' Minute		1.74533 × 10 <sup>-2</sup> rad	
		" Second		2.90888 × 10 <sup>-4</sup> rad 4.84814 × 10 <sup>-6</sup> rad	
Mass	kg	t		— 1 × 10 <sup>3</sup> kg	
Density	kg/m <sup>3</sup>	kg/ℓ t/m <sup>3</sup>		— 1 × 10 <sup>-3</sup> kg/m <sup>3</sup> 1 × 10 <sup>3</sup> kg/m <sup>3</sup>	
Force	N		dyn kgf	— 1 × 10 <sup>-5</sup> N 9,80665N	
Pressure	Pa	bar		—	Used for fluid pressure
			mmAq, mmH <sub>2</sub> O	1 × 10 <sup>5</sup> Pa	
			mAq, mH <sub>2</sub> O	9,80665Pa	
			kgf/cm <sup>2</sup>	9,80665 × 10 <sup>3</sup> Pa	
			mmHg	9,80665 × 10 <sup>4</sup> Pa	
			atm (Steam pressure)	1.3322 × 10 <sup>2</sup> Pa 1,0135 × 10 Pa	
Viscosity	Pa · S	P		— 1 × 10 <sup>-1</sup> Pa · S	
Kinematic viscosity	m <sup>2</sup> /S	St		— 1 × 10 <sup>-4</sup> m <sup>2</sup> /S	
Work/Calorie/ Electric energy	J		kcal kgf · m kW · h	— 4,18605kJ 9,80665J 3,6MJ	According to IT calorie, which indicates values of measurement, 1cal it = 4.1868okj
Temperature	K °C				Thermodynamical temperature Celsius temperature T(K)273.15+t(°C)
Temperature unit	K °C				Indicated as deg before
Specific heat/Entropy	J/(kg · K)		kcal/kg · °C	— 4,18605kJ/(kg · K)	
Enthalpy/Specific latent heat	J/kg		kcal/kg	— 4,18605kJ/kg	
Stress	Pa		kgf/m <sup>2</sup>	9,80665Pa	
	N/m <sup>2</sup>				

## SI unit conversion table

SI stands for the International System of Units (from the French Le Systeme International d'Unites), which was adopted during the General Conference on Weights and Measures (CGPM) in 1960.

### ● Main measurement units that were changed to SI units

Measurements	Changed measurement unit (symbol)	SI unit (symbol)	Unit conversion factors (note 1)
Pressure	(kgw/m <sup>2</sup> , kgf/m <sup>2</sup> , kg/m <sup>2</sup> ) (mHg) Notes 2 (mH <sub>2</sub> O, mAq) (Torr) Notes 3	Pascal (pa)	1kgf/m <sup>2</sup> ≈ 9,8Pa 1mHg ≈ 133kPa 1mH <sub>2</sub> O ≈ 9,8kPa 1Torr=133Pa
Force	(kgw, kgf)	(N)	1kgf ≈ 9,8N
Work	(kgw · m, kgf · m, kg · m)	(N · m)	1kgfm ≈ 9,8N · m
Stress	(kgf/m <sup>2</sup> )	(Pa)	1kgf/m <sup>2</sup> ≈ 9,8Pa
Calorie	(kal) Notes 4	(J)	1cal ≈ 4,2J
Length	(μ)	(m)	1μ = 1μm

### ● The following are main prefixes that compose the integer powers of 10 of SI units.

Factor	Prefix	Symbol	Factor	Prefix	Symbol
10 <sup>6</sup>	Mega	M	10 <sup>-2</sup>	Centimeter	C
10 <sup>3</sup>	Kilo	k	10 <sup>-3</sup>	Millimeter	m
10 <sup>2</sup>	Hectare	h	10 <sup>-6</sup>	Micrometer	μ

Notes 1) The accurate figures for unit conversion are 9.8 → 9.8066, 133 → 133.322, 4.2 → 4.18605.

Notes 2) Certified for use in measuring blood pressure levels. Notes 3) Certified for use in medical-related matters.

Notes 4) Certified for use in nutrition-related matters.



# Data / Saturated Steam Table

Absolute pressure of steam ( a b s )		Steam temperature		Volume of 1 kg of water before evaporation	Volume of 1 kg of steam	Weight of 1 m <sup>3</sup> of steam	Calorie of 1 kg of steam (Kal)			Absolute pressure of steam ( a b s )		Steam temperature		Volume of 1 kg of water before evaporation	Volume of 1 kg of steam	Weight of 1 m <sup>3</sup> of steam	Calorie of 1 kg of steam (Kal)		
(kgf/cm <sup>2</sup> )	(lb/In <sup>2</sup> )	(°C)	(°F)				Water calorie	Latent heat	Total calorie	(kgf/cm <sup>2</sup> )	(lb/In <sup>2</sup> )	(°C)	(°F)				Water calorie	Latent heat	Total calorie
0.02	0.28	17.2	62.9	1.0012	68.26	0.0147	17.2	587.8	605.0	13.50	192.0	192.4	378.3	1.1451	0.1485	6.734	195.5	469.9	665.4
0.04	0.57	28.6	83.5	1.0039	35.46	0.0282	28.7	581.3	610.0	14.00	199.1	194.1	381.4	1.1476	0.1436	6.974	197.3	468.4	665.7
0.06	0.85	35.8	96.4	1.0063	24.18	0.0414	35.8	577.3	613.1	14.50	206.2	195.8	384.4	1.1500	0.1386	7.214	199.0	466.9	665.9
0.08	1.14	41.2	106.2	1.0083	18.44	0.0542	41.2	574.2	615.4	15.00	213.3	197.4	378.3	1.1524	0.1342	7.454	200.7	465.5	666.2
0.10	1.42	45.5	113.9	1.0101	14.95	0.0669	45.4	571.8	617.2	16.00	227.4	200.4	392.7	1.1572	0.1260	7.934	204.1	462.6	666.7
0.15	2.13	53.6	128.5	1.0138	10.21	0.0980	53.5	567.1	620.6	17.00	241.7	203.4	398.1	1.1618	0.1189	8.414	207.2	459.9	667.1
0.20	2.84	59.7	136.5	1.0170	7.791	0.1284	59.6	563.5	623.1	18.00	256.0	206.2	403.2	1.1663	0.1124	8.894	210.2	457.2	667.4
0.25	3.56	64.6	148.3	1.0197	6.319	0.1583	64.5	560.8	625.2	19.00	270.2	208.8	407.8	1.1706	0.1067	9.375	213.1	454.6	667.7
0.30	4.27	68.7	155.7	1.0221	5.326	0.1878	68.7	558.2	626.9	20.00	284.4	211.4	412.5	1.1749	0.1015	9.857	215.9	452.1	668.0
0.35	4.98	72.3	162.1	1.0242	4.609	0.2170	72.2	556.1	628.3	21.00	298.6	213.9	417.0	1.1791	0.0967	10.34	218.6	459.6	668.2
0.40	5.69	75.4	167.7	1.0362	4.067	0.2459	75.4	554.2	629.6	22.00	312.8	216.2	421.2	1.1833	0.0924	10.82	221.2	447.2	668.4
0.45	6.40	78.3	172.9	1.0281	3.642	0.2746	78.3	552.5	630.8	23.00	327.1	218.5	425.3	1.1873	0.0885	11.31	223.8	444.8	668.6
0.50	7.11	80.9	177.6	1.0298	3.300	0.3030	80.9	550.9	631.8	24.00	341.3	220.8	429.4	1.1913	0.0848	11.79	226.2	442.6	668.8
0.60	8.53	85.5	185.9	1.0329	2.782	0.3594	85.5	548.1	633.6	25.00	355.5	222.9	433.2	1.1953	0.0815	12.28	228.6	440.3	668.9
0.70	9.95	89.5	193.1	1.0357	2.408	0.4152	89.5	545.7	635.2	26.00	369.7	225.0	437.0	1.1991	0.0784	12.76	230.9	438.1	669.0
0.80	11.4	93.0	199.4	1.0383	2.125	0.4705	93.0	543.5	636.5	27.00	383.9	227.0	440.6	1.203	0.0755	13.25	233.2	435.9	669.1
0.90	12.8	96.2	205.2	1.0407	1.904	0.5253	96.2	541.5	637.7	28.00	398.2	229.0	444.2	1.207	0.0728	13.74	235.4	433.8	669.2
1.00	14.2	99.1	210.4	1.0430	1.755	0.5797	99.2	539.6	638.8	29.00	412.4	230.9	447.6	1.210	0.0703	14.23	237.5	431.7	669.2
1.20	17.1	104.3	219.7	1.0471	1.454	0.6875	104.4	536.3	640.7	30.00	426.6	232.8	451.0	1.214	0.0679	14.72	239.6	429.7	669.3
1.40	19.9	108.7	227.7	1.0508	1.259	0.7942	108.9	535.5	652.4	32.00	455.0	236.4	457.5	1.221	0.0637	15.70	243.7	425.6	669.3
1.60	22.8	112.7	234.9	1.0542	1.111	0.8999	112.9	530.8	643.7	34.00	483.5	239.8	463.6	1.229	0.0599	16.69	247.6	421.7	669.3
1.80	25.6	116.3	241.3	1.0573	0.9952	1.005	116.6	528.4	645.0	36.00	511.9	243.0	469.4	1.236	0.0565	17.69	251.3	417.9	669.2
2.00	28.4	119.6	247.3	1.0603	0.9018	1.109	199.6	526.3	646.2	38.00	540.4	246.2	475.2	1.243	0.0535	18.69	254.9	414.2	669.1
2.50	35.6	126.8	260.2	1.0669	0.7317	1.367	127.2	521.4	648.6	40.00	566.8	249.2	480.6	1.249	0.0508	19.70	258.4	410.5	669.9
3.00	42.7	132.9	271.2	1.0728	0.6168	1.621	133.4	517.2	650.6	42.00	597.2	252.1	485.8	1.256	0.0483	20.72	261.7	407.0	669.7
3.50	49.8	138.2	280.8	1.0782	0.5337	1.874	138.8	513.4	652.2	44.00	625.7	254.9	490.8	1.263	0.0406	21.74	265.0	403.5	668.5
4.00	56.9	142.9	289.2	1.0831	0.4708	2.124	143.7	510.0	653.7	46.00	654.1	257.6	495.7	1.269	0.0439	22.77	268.2	400.0	668.2
4.50	64.0	147.2	297.0	1.0877	0.4214	2.373	148.1	506.8	654.9	48.00	682.6	260.2	500.4	1.276	0.0420	23.80	271.3	396.6	667.9
5.00	71.1	151.1	304.0	1.0920	0.3816	2.620	152.1	503.9	656.0	50.00	711.0	262.7	504.9	1.283	0.0402	24.85	274.3	393.3	667.6
5.50	78.2	154.7	310.5	1.0961	0.3489	2.877	155.8	501.2	657.0	55.00	782.1	268.7	515.7	1.299	0.0364	27.49	218.5	385.1	666.6
6.00	85.3	158.1	316.6	1.1000	0.3213	3.112	159.3	498.6	657.9	60.00	853.2	274.3	525.7	1.315	0.3331	30.18	288.3	377.2	666.5
6.50	92.4	161.2	322.2	1.1307	0.2980	3.356	162.6	496.1	658.7	65.00	924.3	279.5	535.1	1.331	0.0304	32.93	294.8	369.4	664.2
7.00	99.5	164.2	327.6	1.1072	0.2778	3.600	165.7	493.8	659.5	70.00	995.4	284.5	544.1	1.347	0.0280	35.75	301.0	361.8	662.8
7.50	106.7	167.0	332.6	1.111	0.2602	3.843	168.6	491.6	660.2	75.00	1066.5	289.2	552.6	1.363	0.0259	38.62	307.0	354.3	661.3
8.00	113.8	169.6	337.3	1.1140	0.2448	4.086	171.3	489.5	660.8	80.00	1137.6	293.6	560.5	1.379	0.0241	41.56	312.8	346.9	659.7
8.50	120.9	172.1	341.8	1.1172	0.2311	4.328	174.0	487.4	661.4	85.00	1208.7	297.9	568.2	1.395	0.0224	44.58	318.4	339.6	658.0
9.00	128.0	174.5	346.1	1.1203	0.2188	4.570	176.5	485.4	661.9	90.00	1279.8	301.9	585.4	1.412	0.0210	47.67	323.8	332.4	656.2
9.50	135.1	176.8	350.2	1.1233	0.2079	4.811	178.9	483.5	662.4	95.00	1350.9	305.8	585.4	1.429	0.0197	50.85	329.1	325.2	654.3
10.00	142.2	179.0	354.2	1.1262	0.1979	5.052	181.3	481.6	662.9	100.00	1422.0	309.5	589.1	1.446	0.0185	54.12	334.3	318.0	652.3
10.50	149.3	181.2	358.2	1.1291	0.1890	5.293	183.5	479.8	663.3	120.00	1706.4	323.1	613.6	1.518	0.0147	68.22	354.0	289.4	643.4
11.00	156.4	183.2	361.8	1.1319	0.1807	5.533	185.6	478.1	663.7	140.00	1990.8	335.1	653.2	1.599	0.0118	84.52	372.8	260.0	632.8
11.50	163.5	185.2	365.4	1.1346	0.1732	5.774	187.7	476.4	664.1	160.00	2275.2	345.8	654.4	1.693	0.0096	104.0	391.8	228.4	619.7
12.00	170.6	187.1	368.8	1.1373	0.1663	6.014	189.8	474.7	664.5	180.00	2559.6	355.4	671.7	1.814	0.0078	128.3	410.8	192.9	603.7
12.50	177.8	188.9	372.0	1.1400	0.1599	6.254	191.7	473.1	664.8	200.00	2844.0	364.1	687.4	1.990	0.0062	161.6	431.6	151.2	582.8
13.00	184.9	190.7	375.3	1.1425	0.1540	6.494	193.6	471.5	665.1	225.56	3208.7	374.15	705.47	3.170	0.0032	315.5	503.3	0	503.3



# Data / Overheated Steam Table

Absolute pressure (kgf/cm <sup>2</sup> )		Steam temperature (°C)							
		100	150	200	250	300	350	400	450
0.1	v	17.54	19.90	22.26	24.61	26.97	29.32	31.68	34.03
(45.45)	i	641.9	664.7	687.8	711.2	734.8	783.3	758.9	808.1
0.5	v	3.486	3.967	4.442	4.916	5.388	5.860	6.332	6.803
(80.86)	i	640.7	664.0	687.3	710.8	734.6	758.7	783.2	808.0
1	v	1.730	1.975	2.215	2.454	2.691	2.927	3.164	3.400
(99.09)	i	639.3	663.1	686.8	710.5	734.3	758.5	783.0	807.9
2	v		0.6466	1.102	1.223	1.342	1.461	1.580	1.698
(119.61)	i		661.3	685.6	709.7	733.8	758.1	782.6	807.6
3	v		0.9788	0.7307	0.8123	0.8927	0.9724	1.052	1.131
(132.88)	i		659.4	684.5	708.9	733.2	757.6	782.3	807.3
4	v		0.4803	0.5450	0.6071	0.6679	0.7280	0.7878	0.8474
(142.92)	i		657.5	683.3	708.1	732.6	757.2	781.9	807.0
5	v			0.4336	0.4840	0.5330	0.5814	0.6294	0.6772
(151.11)	i			682.1	707.3	732.1	756.7	781.6	806.7
6	v			0.3592	0.4018	0.4431	0.4836	0.5238	0.5638
(158.08)	i			680.8	706.5	731.51	756.3	781.2	806.4
7	v			0.3060	0.3432	0.3788	0.4138	0.4484	0.4827
(164.17)	i			679.5	705.7	730.9	755.8	780.8	806.1
8	v			0.2662	0.2992	0.3307	0.3614	0.3918	0.4220
(169.61)	i			678.2	704.8	730.3	755.4	780.5	805.8
9	v			0.2351	0.2649	0.2932	0.3207	0.3478	0.3747
(174.53)	i			676.8	704.0	729.7	754.9	780.1	805.5
10	v			0.2103	0.2375	0.2632	0.2881	0.3126	0.3369
(179.04)	i			675.4	703.1	729.1	754.5	779.8	805.2
12	v			0.1729	0.1964	0.2182	0.2392	0.2598	0.2802
(187.08)	i			672.6	701.3	727.9	753.6	779.0	804.6
15	v			0.1353	0.1552	0.1732	0.1903	0.2070	0.2234
(197.37)	i			668.0	689.6	726.0	752.2	777.9	803.6
20	v				0.1139	0.1282	0.1414	0.1542	0.1667
(211.39)	i				693.6	722.8	749.8	776.1	802.1
30	v				0.07218	0.08291	0.09242	0.1014	0.1100
(232.76)	i				682.6	715.8	744.9	772.3	799.0
40	v				0.05093	0.06016	0.06787	0.07491	0.08160
(249.18)	i				669.7	708.1	739.7	768.4	795.9
50	v					0.04637	0.05309	0.05902	0.06457
(262.69)	i					699.6	734.1	764.3	792.7
60	v					0.03706	0.04318	0.04841	0.05320
(274.28)	i					690.3	728.2	760.1	789.4
80	v					0.02500	0.03068	0.03509	0.03897
(293.61)	i					667.7	715.2	751.1	782.6
100	v						0.02302	0.02703	0.03041
(309.53)	i						700.4	741.4	755.5
120	v							0.01030	0.01305
(364.07)	i							677.1	733.8

V=Volume of 1 kg of steam (m<sup>3</sup>/kg), i=Calorie of 1 kg of steam (kcal/kg)

# Data / Fluid Viscosity

## Oil temperature and viscosity curve

Engineering viscosity unit conversion

$$v = \frac{\mu}{\rho}$$

v = Viscosity(stokes : St. centistokes : cSt)

$\mu$  : Absolute viscosity(Poise : P.centipoise : cP)

$\rho$  : Density(g/cm<sup>3</sup>)

1Poise = 100 centipoise

1stokes = 100 centistokes

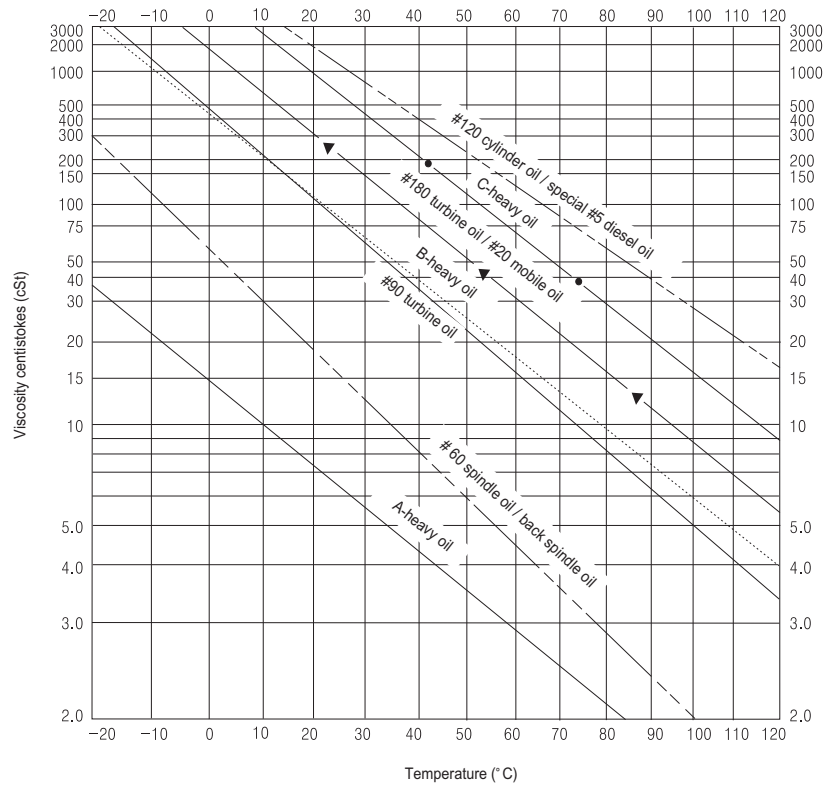

## Viscosity conversion table

Centistokes (c s t)	Saybolt Universal Second (SSU) (Second)	Redwood (No. 1) Second R (Second)	Engler Degree E (Degree)	Centistokes (c s t)	Saybolt Universal Second (SSU) (Second)	Redwood (No. 1) Second R (Second)	Engler Degree E (Degree)
2.7	35	32.2	1.18	103	475	419	13.5
4.3	40	36.2	1.32	108	500	441	14.2
5.9	45	40.6	1.46	119	550	485	15.6
7.4	50	44.9	1.60	130	600	529	17.0
8.9	55	49.1	1.75	141	650	573	18.5
10.4	60	53.5	1.88	152	700	617	19.9
11.8	65	57.9	2.02	163	750	661	21.3
13.1	70	62.3	2.15	173	800	705	22.7
14.5	75	67.6	2.31	184	850	749	24.2
15.8	80	71.0	2.42	195	900	793	25.6
17.0	85	75.1	2.55	206	950	837	27.0
18.2	90	79.6	2.68	217	1000	882	28.4
19.4	95	84.2	2.81	260	1200	1058	34.1
20.6	100	88.4	2.95	302	1400	1234	39.8
23.0	110	97.1	3.21	347	1600	1411	45.5
25.0	120	105.9	3.49	390	1800	1587	51
27.5	130	114.8	3.77	433	2000	1763	57
29.8	140	123.6	4.04	542	2500	2204	71
32.1	150	132.4	4.32	650	3000	2646	85
34.3	160	141.1	4.59	758	3500	3087	99
36.5	170	150.0	4.88	867	4000	3526	114
38.8	180	158.8	5.15	974	4500	3967	128
41.0	190	167.5	5.44	1082	5000	4408	142
43.2	200	176.4	5.72	1150	5500	4849	156
47.5	220	194.0	6.28	1300	6000	5290	160
51.9	240	212	6.85	1400	6500	5730	185
56.5	260	229	7.38	1510	7000	6171	199
60.5	280	247	7.95	1630	7500	6612	213
64.9	300	265	8.51	1740	8000	7053	227
70.3	325	287	9.24	1850	8500	7494	242
75.8	350	309	9.95	1960	9000	7934	256
81.2	375	331	10.7	2070	9500	8375	270
86.8	400	353	11.4	2200	10000	8816	284
92.0	425	375	12.1				
97.4	450	397	12.8				



# Data / Vapor Viscosity Table

Number	Vapor	X	Y	Number	Vapor	X	Y
1	Acetic acid	7.7	14.6	29	Freon-113	11.3	14.0
2	Acetone	8.9	13.0	30	Helium	10.9	20.5
3	Acetylene	9.8	14.9	31	Hexane	8.6	11.8
4	Air	11.0	20.0	32	Hydrogen	11.2	12.4
5	Ammonia	8.4	16.0	33	3H <sub>2</sub> +N <sub>2</sub>	11.2	17.2
6	Argon	10.5	22.4	34	Hydrogen bromide	8.8	20.9
7	Benzene	8.5	13.2	35	Hydrogen chloride	8.8	18.7
8	Bromine	8.9	19.2	36	Hydrogen cyanide	9.8	14.9
9	Butene	9.2	13.7	37	Hydrogen iodide	9.0	21.3
10	Butylene	8.9	13.0	38	Hydrogen sulfide	8.6	18.0
11	Carbon dioxide	9.5	18.7	39	Iodine	9.0	18.4
12	Carbon disulfide	8.0	16.0	40	Mercury	5.3	22.9
13	Carbon monoxide	11.0	20.0	41	Methane	9.9	15.5
14	Chlorine	9.0	18.4	42	Methyl alcohol	8.5	15.6
15	Chloroform	8.9	15.7	43	Nitric oxide	10.9	20.5
16	Cyanogen	9.2	15.2	44	Nitrogen	10.6	20.0
17	Cyclohexane	9.2	12.0	45	Nitrosyl chloride	8.0	17.6
18	Ethane	9.1	14.5	46	Nitrous Oxide	8.8	19.0
19	Ethyl acetate	8.5	13.2	47	Oxygen	11.0	21.3
20	Ethyl alcohol	9.2	14.2	48	Pentane	7.0	12.8
21	Ethyl chloride	8.5	15.6	49	Propane	9.7	12.9
22	Ethyl ether	8.9	13.0	50	Propyl alcohol	8.4	13.4
23	Ethylene	9.5	15.1	51	Propylene	9.0	13.8
24	Fluorine	7.3	23.8	52	Sulfur dioxide	9.6	17.0
25	Freon-11	10.6	15.1	53	Toluene	8.6	12.4
26	Freon-12	11.1	16.0	54	2,3,3-Trimethylbutane	9.5	10.5
27	Freon-21	10.8	15.3	55	Water	8.0	16.0
28	Freon-22	10.1	17.0	56	Xenon	9.3	23.0

## ■ How to find viscosity by chart

Assuming that the vapor type is 20°C air

- 1) Find the air's coordinates in the table above. (X=11.0, Y=20.0)
- 2) Indicate the X and Y values on the coordinates table on the next page. (Point A)
- 3) Read the value of the point of intersection between the viscosity table on the right and the extended line that connects point A with the 20°C point of the temperature table on the left.
- 4) The viscosity of 20°C air is 0.018cP.

## ■ How to convert cP into cSt

Vapor cP / Vapor density (g/cm<sup>3</sup>) = Vapor cSt

Example) When converting the viscosity of 20°C air (0.018cP) into cSt (air density : 1.20 X 10<sup>-3</sup>g/cm<sup>3</sup>)

# Data

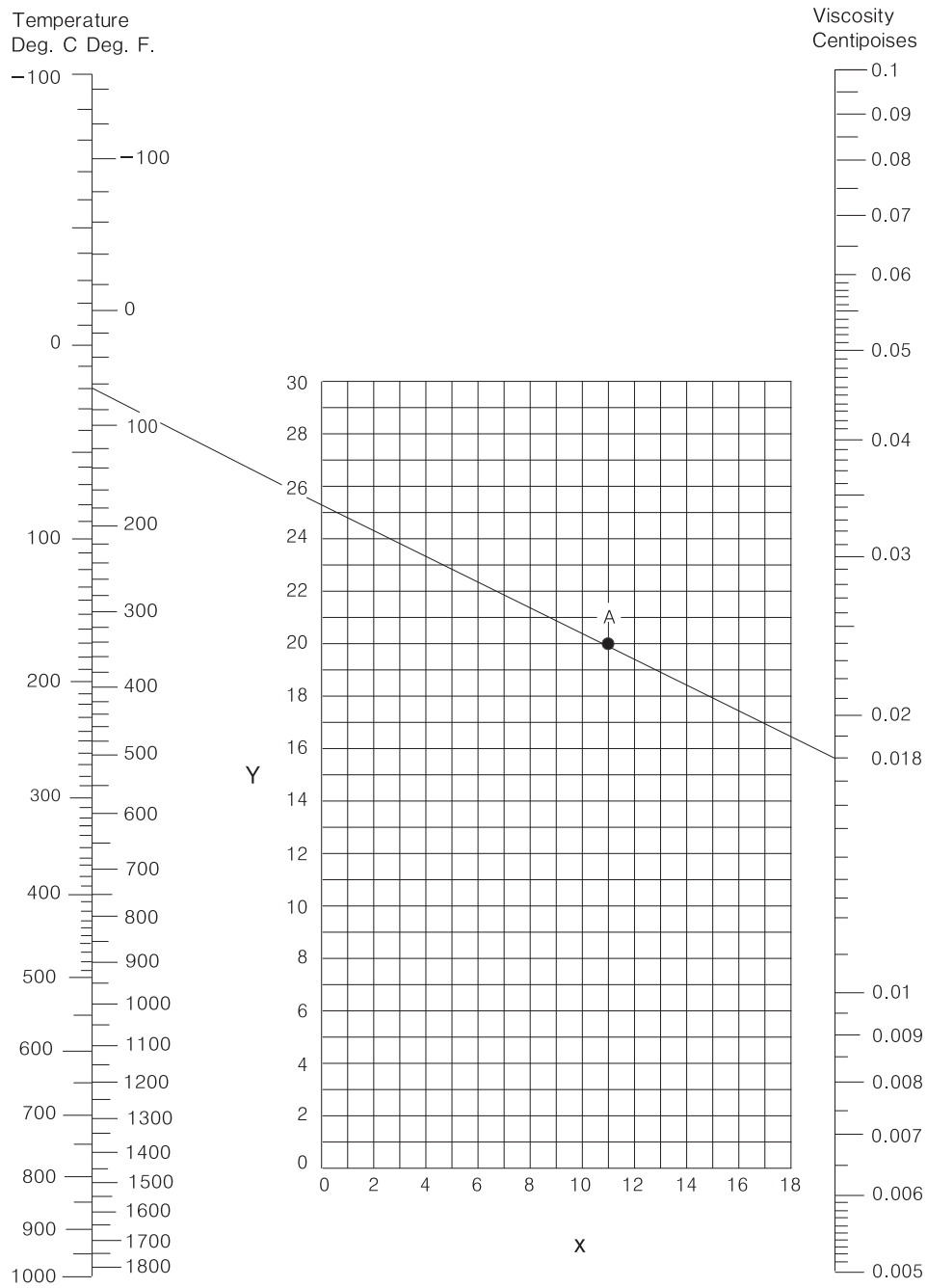

Refer to the previous page for the viscosity (1 atm) and coordinates of vapor and steam.



# Data / Liquid Viscosity Table

Number	Vapor	X	Y	Number	Vapor	X	Y
1	Acetaldehyde	15.2	4.8	56	Freon-22	17.2	4.7
2	Acetic acid, 100%	12.1	14.2	57	Freon-113	12.5	11.4
3	Acetic acid, 70%	9.5	17.0	58	Glycerol, 100%	2.0	30.0
4	Acetic anhydride	12.7	12.8	59	Glycerol, 50%	6.9	19.6
5	Acetone, 100%	14.5	7.2	60	Heptane	14.1	8.4
6	Acetone, 35%	7.9	15.0	61	Hexane	14.7	7.0
7	Allyl alcohol	10.2	14.3	62	Hydrochloric acid, 31.5%	13.0	16.6
8	Ammonia, 100%	12.6	2.0	63	Isobutyl alcohol	7.1	18.0
9	Ammonia, 26%	10.1	13.9	64	Isobutyl acid	12.2	14.4
10	Amyl acetate	11.8	12.5	65	Isobutyric alcohol	8.2	16.0
11	Amyl alcohol	7.5	18.4	66	Kerosene	10.2	16.9
12	Aniline	8.1	18.7	67	Linseed oil, raw	7.5	27.2
13	Anisole	12.3	13.5	68	Mercury	18.4	16.4
14	Arsenic trichloride	13.9	14.5	69	Methanol, 100%	12.4	10.5
15	Benzene	12.5	10.9	70	Methanol, 90%	12.3	11.8
16	Bimethyl oxalate	12.3	15.8	71	Methanol, 40%	7.8	15.5
17	Biphenyl	12.0	18.3	72	Methyl acetate	14.2	8.2
18	Brine, CaCl <sub>2</sub> , 25%	6.6	15.9	73	Methyl chloride	15.0	3.8
19	Brine NaCl, 25%	10.2	16.6	74	Methyl ethyl ketone	13.9	8.6
20	Bromine	14.2	13.2	75	Naphthalene	7.9	18.1
21	Bromotoluene	20.0	15.9	76	Nitric acid, 95%	12.8	13.8
22	Butyl acetate	12.3	11.0	77	Nitric acid, 60%	10.8	17.0
23	Butyl alcohol	8.6	17.2	78	Nitrobenzene	10.6	16.2
24	Butyric acid	12.1	15.3	79	Nitrotoluene	11.0	17.0
25	Carbon dioxide	11.6	0.3	80	Octane	13.7	10.0
26	Carbon disulfide	16.1	7.5	81	Octyl alcohol	6.6	21.1
27	Carbon tetrachloride	12.7	13.4	82	Pentachloroethane	10.9	17.3
28	Chlorobenzene	12.3	12.4	83	Pentane	14.9	5.2
29	Chloroform	14.4	10.2	84	Phenol	6.9	20.8
30	Chlorosulfonic acid	11.2	18.1	85	Phosphorus tribromide	13.8	16.7
31	o-Chlorotoluene	13.0	13.3	86	Phosphorus trichloride	16.2	10.9
32	m-Chlorotoluene	13.3	12.5	87	Propionic acid	12.8	13.8
33	p-Chlorotoluene	13.3	12.5	88	Propyl alcohol	9.1	16.5
34	m-resol	2.5	20.8	89	Propyl bromide	14.5	9.6
35	Cyclohexanol	2.9	24.3	90	Propyl chloride	14.4	7.5
36	Dibromoethane	12.7	15.8	91	Propyl iodide	14.1	11.6
37	Dichloroethane	13.2	12.2	92	Sodium	16.4	13.9
38	Dichloromethane	14.6	8.9	93	Sodium hydroxide, 50%	3.2	25.8
39	Diethyl oxalate	11.0	16.4	94	Stannic chloride	13.5	12.8
40	Dipropyl oxalate	10.3	17.7	95	Sulfur dioxide	15.2	7.1
41	Ethyl acetate	13.7	9.1	96	Sulfuric acid, 110%	7.2	27.4
42	Ethyl alcohol, 100%	10.5	13.8	97	Sulfuric acid, 98%	7.0	24.8
43	Ethyl alcohol, 95%	9.8	14.3	98	Sulfuric acid, 60%	10.2	21.3
44	Ethyl alcohol, 40%	6.5	16.6	99	Suluryl chloride	15.2	12.4
45	Ethyl benzene	13.2	11.5	100	Tetrachloroethane	11.9	15.7
46	Ethyl bromide	14.5	8.1	101	Tetrachloroethylene	14.2	12.7
47	Ethyl chloride	14.8	6.0	102	Titanium tetrachloride	14.4	12.3
48	Ethyl ether	14.5	5.3	103	Toluene	13.7	10.4
49	Ethyl formate	14.2	8.4	104	Trichloroethylene	14.8	10.5
50	Ethyl iodide	14.7	10.3	105	Turpentine	11.5	14.9
51	Ethylene glycol	6.0	23.6	106	Vinyl acetate	14.0	8.8
52	formic acid	10.7	15.8	107	Water	10.2	13.0
53	Freon-11	14.4	9.0	108	o-Xylene	13.5	12.1
54	Freon-12	16.8	5.6	109	m-Xylene	13.9	10.6
55	Freon-21	15.7	7.5	110	p-Xylene	13.9	10.9

## ■ How to find viscosity by chart

Assuming that the liquid type is 90°C water

- 1) Find the water's coordinates in the table above. (X=10.2, Y=13.0)
- 2) Indicate the X and Y values on the coordinates table on the next page. (Point A)
- 3) Read the value of the point of intersection between the viscosity table on the right and the extended line that connects point A with the 90°C point of the temperature table on the left.
- 4) The viscosity of 90°C water is 0.3cP.

# Data

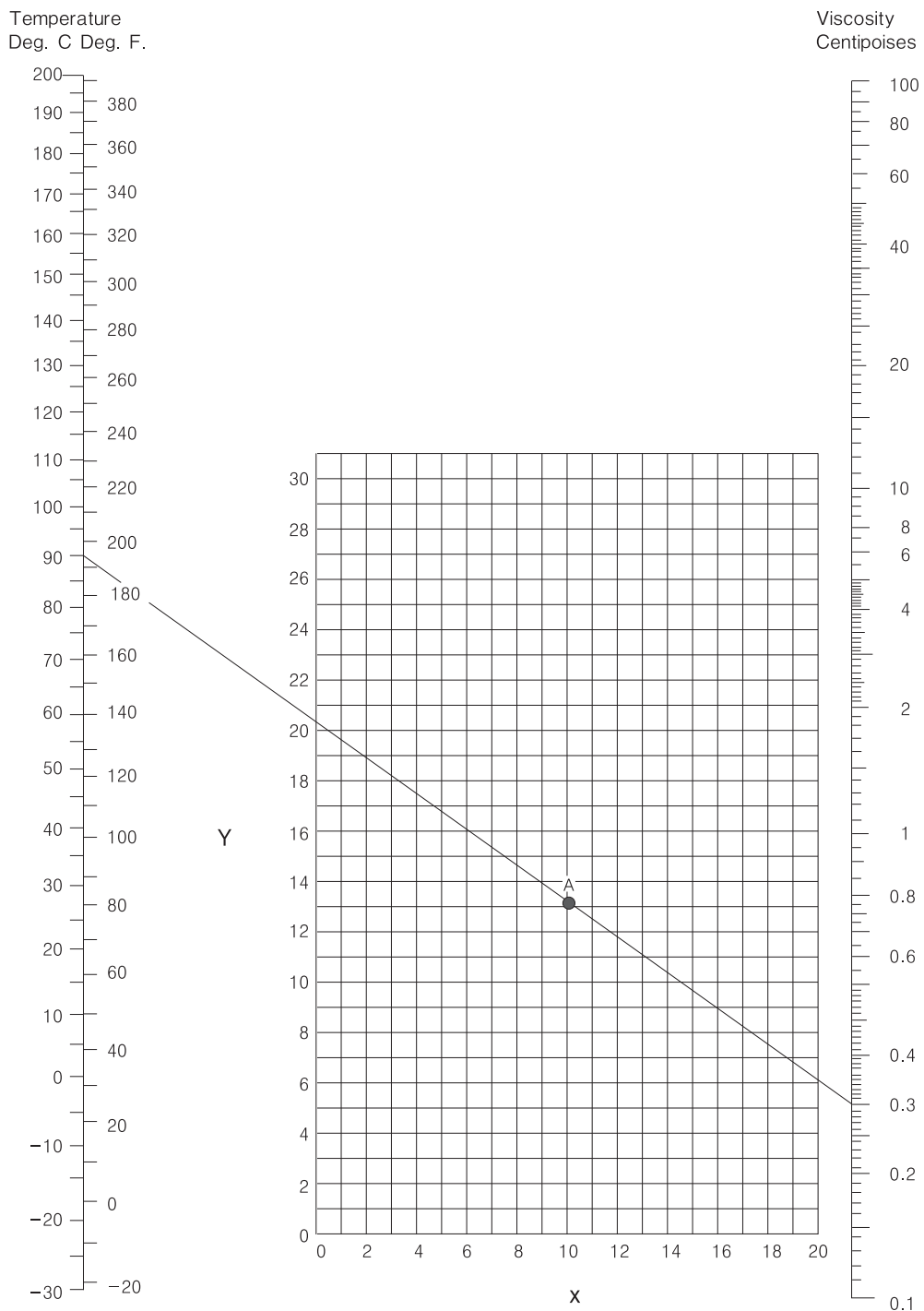

Refer to the previous page for the viscosity (1 atm) and coordinates of liquid and steam.



# Data / Size Selection

## Method based on Cv formula

Cv value : A valve's Cv value refers to clear water, with a temperature of 60° F(15.6° C) flowing for 1 minute, when the differential pressure between the inlet and outlet side of the valve is maintained at 1 psi (0.07 kgf/cm<sup>2</sup>), indicated in US gal/min.

### ■ Calculation procedure

1. Selection of a nominal diameter is usually based on the Cv method. In this case, calculate the Cv value for each of the differential pressures for maximum, normal, and minimum flows. In other words, the Cv value when there is maximum flow and minimum differential pressure becomes the maximum Cv value. The Cv value when there is minimum flow and maximum differential pressure becomes the minimum Cv value.
2. A nominal diameter is usually selected by making room for an additional 10 to 20% to the maximum Cv value. In addition, the minimum adjustable flow or rangeability (ratio of the controllable maximum flow and minimum flow) is defined according to the control valve type. As such, attention should be paid to the calculated minimum Cv value as well.

### ■ Cv value calculation formula

#### 1. Steam

In the case of,  $\Delta P < \frac{P_1}{2}$   $C_v = \frac{WK}{13.67\sqrt{\Delta P(P_1+P_2)}}$ ,  $W = C_v \times \frac{13.67 \sqrt{\Delta P(P_1+P_2)}}{K}$

In the case of,  $\Delta P \geq \frac{P_1}{2}$   $C_v = \frac{WK}{11.9P_1}$ ,  $W = C_v \frac{11.9P_1}{K}$

#### 2. Vapor

In the case of,  $\Delta P < \frac{P_1}{2}$   $C_v = \frac{Q}{287} \sqrt{\frac{G(273+t)}{\Delta P(P_1+P_2)}}$ ,  $Q = C_v \times \frac{287}{\sqrt{\frac{G(273+t)}{\Delta P(P_1+P_2)}}$

In the case of,  $\Delta P \geq \frac{P_1}{2}$   $C_v = \frac{Q\sqrt{G(273+t)}}{249P_1}$ ,  $Q = C_v \times \frac{249P_1}{\sqrt{G(273+t)}}$

#### 3. Liquid

$$C_v = \frac{1.167V\sqrt{G}}{\sqrt{P_1-P_2}}, V = C_v \times \frac{\sqrt{P_1-P_2}}{1.167\sqrt{G}}$$

W = Maximum flow kg/h  
 P<sub>1</sub> = Primary pressure kgf/cm<sup>2</sup>(abs)  
 P<sub>2</sub> = Secondary pressure kgf/cm<sup>2</sup>(abs)  
 $\Delta P = P_1 - P_2$  kgf/cm<sup>2</sup>  
 K = 1+(0.0013×Degree of superheating ° C)

Q = Maximum flow Nm<sup>3</sup>/h  
 (In the case of 15° C 760mmHg abs)

G = Specific gravity (Air=1)  
 t = Temperature ° C  
 P<sub>1</sub> = Primary pressure kgf/cm<sup>2</sup>(abs)  
 P<sub>2</sub> = Secondary pressure kgf/cm<sup>2</sup>(abs)  
 $\Delta P = P_1 - P_2$  kgf/cm<sup>2</sup>

V = Maximum flow m<sup>3</sup>/h  
 G = Specific gravity (Water=1)  
 P<sub>1</sub> = Primary pressure kgf/cm<sup>2</sup>(abs)  
 P<sub>2</sub> = Secondary pressure kgf/cm<sup>2</sup>(abs)

### ■ Viscosity correction calculation formula

Carry out viscosity correction based on the following method for liquid that has a viscosity of 100 (SSU) or 20(cSt) or higher.

1. Use the liquid's Cv calculation formula to determine the Cv value, without considering the viscosity's effect.
2. Determine the viscosity coefficient (Iv) by the following formula.
3. Determine the correction coefficient (K) by the Viscosity Coefficient Iv-Cv Correction Coefficient K Relationship Chart.
4. Multiply the correction coefficient (K) by the Cv value that was initially calculated.
5. This value is the corrected Cv value.

$$I_v = \frac{44,000Q}{\sqrt{C_v} McSt} \text{ or, } I_v = \frac{205,000Q}{\sqrt{C_v} Mssu}$$

Viscosity-corrected Cv = Cv before viscosity correction X K

Q = Maximum flow m<sup>3</sup>/h  
 McSt = Viscosity cSt  
 Mssu = Viscosity SSU (Saybolt Universal Second)  
 Cv = Cv value before viscosity correction

### ■ Viscosity Index Iv-Cv Correction Coefficient K Relationship Chart

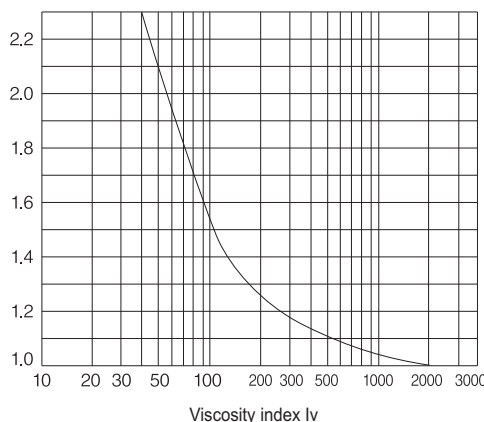

# Data / Size Selection

## Water

### ■ Unit flow table (Water)

P2	P1	P1 = Primary pressure (kgf/cm <sup>2</sup> G)																															
		1	1.5	2	2.5	3	3.5	4	4.5	5	5.5	6	6.5	7	7.5	8	8.5	9	9.5	10	11	12	13	14	15	16	18	20	22	24	26	28	30
0(Air)	0.8568	0.049	1.211	1.354	1.484	1.603	1.713	1.817	1.916	2.009	2.098	2.184	2.267	2.346	2.423	2.498	2.570	2.641	2.709	2.842	2.968	3.089	3.206	3.318	3.427	3.535	3.632	3.832	4.019	4.197	4.369	4.534	4.683
0.2	0.7664	0.9770	1.149	1.299	1.433	1.556	1.670	1.776	1.877	1.972	2.063	2.150	2.234	2.315	2.393	2.468	2.541	2.613	2.682	2.816	2.943	3.065	3.183	3.296	3.406	3.515	3.812	4.000	4.180	4.352	4.518	4.677	
0.35	0.6908	0.9189	1.100	1.256	1.394	1.520	1.637	1.745	1.847	1.944	2.036	2.125	2.209	2.291	2.370	2.446	2.520	2.592	2.661	2.796	2.924	3.047	3.165	3.279	3.389	3.599	3.798	3.987	4.167	4.339	4.505	4.665	
0.5	0.6059	0.8568	1.049	1.211	1.354	1.484	1.603	1.713	1.817	1.916	2.009	2.098	2.184	2.267	2.346	2.423	2.498	2.570	2.641	2.776	2.905	3.029	3.148	3.262	3.373	3.584	3.763	3.973	4.153	4.327	4.493	4.654	
1	0.6059	0.8568	1.049	1.211	1.354	1.484	1.603	1.713	1.817	1.916	2.009	2.098	2.184	2.267	2.346	2.423	2.498	2.570	2.709	2.942	3.089	3.206	3.318	3.427	3.535	3.735	3.926	4.109	4.284	4.452	4.614		
1.5	0.6059	0.8568	1.049	1.211	1.354	1.484	1.603	1.713	1.817	1.916	2.009	2.098	2.184	2.267	2.346	2.423	2.498	2.641	2.776	2.905	3.029	3.148	3.262	3.373	3.584	3.735	3.926	4.109	4.284	4.452	4.614		
2	0.6059	0.8568	1.049	1.211	1.354	1.484	1.603	1.713	1.817	1.916	2.009	2.098	2.184	2.267	2.346	2.423	2.498	2.641	2.776	2.905	3.029	3.148	3.262	3.373	3.584	3.735	3.926	4.109	4.284	4.452	4.614		
2.5	0.6059	0.8568	1.049	1.211	1.354	1.484	1.603	1.713	1.817	1.916	2.009	2.098	2.184	2.267	2.346	2.423	2.498	2.641	2.776	2.905	3.029	3.148	3.262	3.373	3.584	3.735	3.926	4.109	4.284	4.452	4.614		
3	0.6059	0.8568	1.049	1.211	1.354	1.484	1.603	1.713	1.817	1.916	2.009	2.098	2.184	2.267	2.346	2.423	2.498	2.641	2.776	2.905	3.029	3.148	3.262	3.373	3.584	3.735	3.926	4.109	4.284	4.452	4.614		
4	0.6059	0.8568	1.049	1.211	1.354	1.484	1.603	1.713	1.817	1.916	2.009	2.098	2.184	2.267	2.346	2.423	2.498	2.641	2.776	2.905	3.029	3.148	3.262	3.373	3.584	3.735	3.926	4.109	4.284	4.452	4.614		
5	0.6059	0.8568	1.049	1.211	1.354	1.484	1.603	1.713	1.817	1.916	2.009	2.098	2.184	2.267	2.346	2.423	2.498	2.641	2.776	2.905	3.029	3.148	3.262	3.373	3.584	3.735	3.926	4.109	4.284	4.452	4.614		
6	0.6059	0.8568	1.049	1.211	1.354	1.484	1.603	1.713	1.817	1.916	2.009	2.098	2.184	2.267	2.346	2.423	2.498	2.641	2.776	2.905	3.029	3.148	3.262	3.373	3.584	3.735	3.926	4.109	4.284	4.452	4.614		
7	0.6059	0.8568	1.049	1.211	1.354	1.484	1.603	1.713	1.817	1.916	2.009	2.098	2.184	2.267	2.346	2.423	2.498	2.641	2.776	2.905	3.029	3.148	3.262	3.373	3.584	3.735	3.926	4.109	4.284	4.452	4.614		
8	0.6059	0.8568	1.049	1.211	1.354	1.484	1.603	1.713	1.817	1.916	2.009	2.098	2.184	2.267	2.346	2.423	2.498	2.641	2.776	2.905	3.029	3.148	3.262	3.373	3.584	3.735	3.926	4.109	4.284	4.452	4.614		
9	0.6059	0.8568	1.049	1.211	1.354	1.484	1.603	1.713	1.817	1.916	2.009	2.098	2.184	2.267	2.346	2.423	2.498	2.641	2.776	2.905	3.029	3.148	3.262	3.373	3.584	3.735	3.926	4.109	4.284	4.452	4.614		
10	0.6059	0.8568	1.049	1.211	1.354	1.484	1.603	1.713	1.817	1.916	2.009	2.098	2.184	2.267	2.346	2.423	2.498	2.641	2.776	2.905	3.029	3.148	3.262	3.373	3.584	3.735	3.926	4.109	4.284	4.452	4.614		
12	0.6059	0.8568	1.049	1.211	1.354	1.484	1.603	1.713	1.817	1.916	2.009	2.098	2.184	2.267	2.346	2.423	2.498	2.641	2.776	2.905	3.029	3.148	3.262	3.373	3.584	3.735	3.926	4.109	4.284	4.452	4.614		
14	0.6059	0.8568	1.049	1.211	1.354	1.484	1.603	1.713	1.817	1.916	2.009	2.098	2.184	2.267	2.346	2.423	2.498	2.641	2.776	2.905	3.029	3.148	3.262	3.373	3.584	3.735	3.926	4.109	4.284	4.452	4.614		

P2 = Secondary pressure (kgf/cm<sup>2</sup>G)

### ■ Cv value

Product name	Type	Size																	
		15	20	25	32	40	50	65	80	100	125	150	200	250	300	350	400		
Pressure reducing valve	YPR-2A	2.1	2.1	3.5	8	8	14	22	32	48	108								
	YAWR-1						40	62.5	90	160	250	360	640	1000	1440	1960	2560		
	YPR-2,20F			6	9.4	13.5	24	37.5	54	96	150	216							
	YPR-40F					8	14	22	32	48	75	108							
Primary pressure control valve	YPR-10S,10F			3.5	5.7	8.5	13.5	17	25	40									
	YPR-2W	2.1	2.1	3.5	8	8	14	22	32	48	108								
	YAWM-1					40	62.5	90	160	250	360	640	1000	1440	1960	2560			

### [How to select a nominal diameter]

1 : (Cv value to be calculated) =  $\frac{\text{(Maximum designated flow)}}{\text{(unit flow)}}$

2 : Correction by specific gravity (G) (Correction unit flow) =  $\text{(Unit flow)} \times \sqrt{\frac{1}{G}}$

### [Cautions]

1 : Unit flow refers to the flow per 1 Cv value under each pressure condition.

2 : The pressure range and off set are different for each type.





# Data / Flow Velocity within Pipeline Water, Air

## Water / air flow velocity chart

Flow calculation formula

$$Q = \frac{\pi}{4} A^2 \times V \times 3600 \times 10^{-6}$$

$$Q = \text{m}^3/\text{h}(\text{Flow})$$

$$A = \text{mm}(\text{Nominal diameter of pipeline})$$

$$V = \text{m/s}(\text{Flow velocity})$$

Water flow  
 $\text{m}^3/\text{h}$     $\ell / \text{min}$

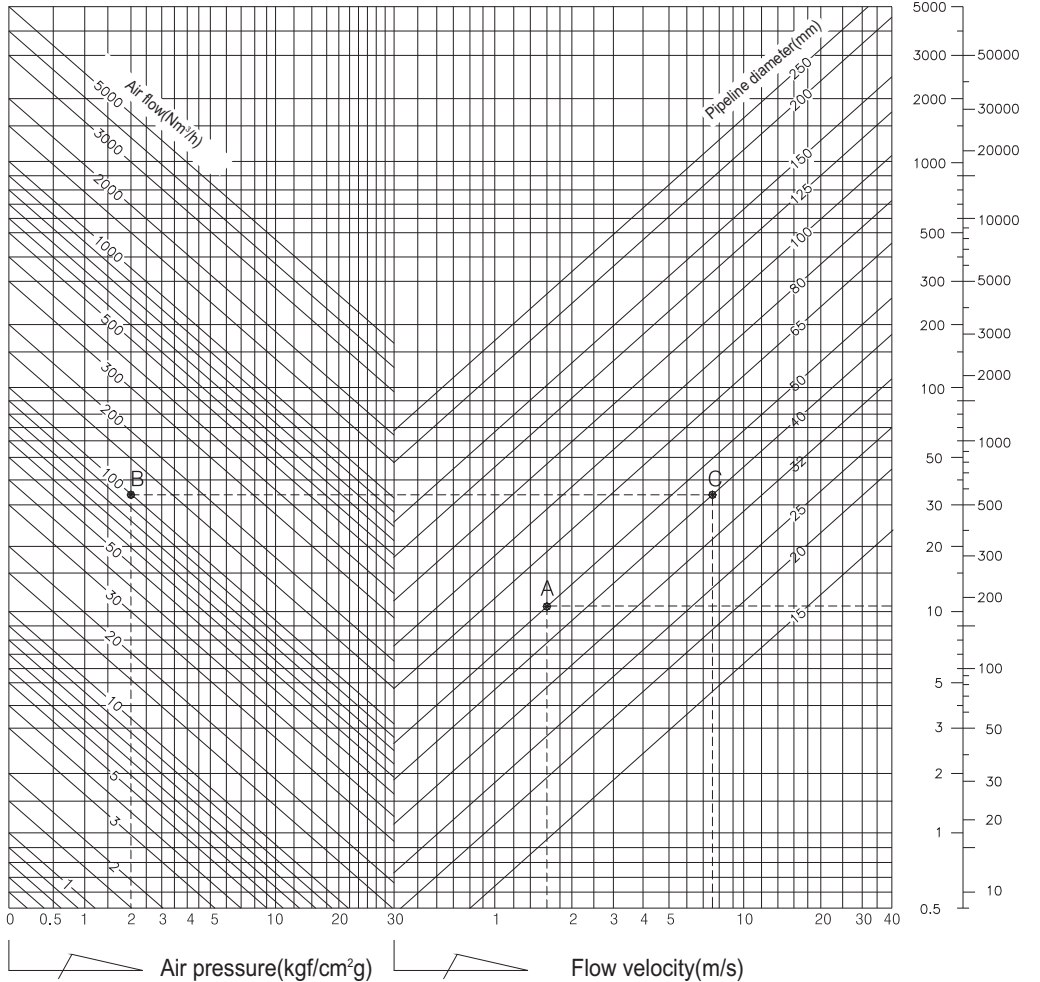

### How to use the chart

**Example 1:** To obtain the flow velocity when the water flow is 11 m<sup>3</sup>/h and the pipeline diameter is 50 mm,

Determine A, the point of intersection between the pipeline diameter of 50 mm and a horizontal line from the flow of 11 m<sup>3</sup>/h. Go down vertically from point A to read a flow velocity of 1.6 m/s.

**Example 2:** To obtain the flow velocity when the air flow is 100 Nm<sup>3</sup>/h, pressure is 2 kgf/cm<sup>2</sup>g, and pipeline diameter is 40 mm,

Determine B, the point of intersection between the air flow of 100 Nm<sup>3</sup>/h and air pressure of 2 kgf/cm<sup>2</sup>g. Then determine C, the point of intersection between the pipeline diameter of 40 mm with a horizontal line from point B. Go down vertically from point C to read a flow velocity of 7.5 m/s. This is the flow velocity.

### Standard flow velocity by use

1. Pump
  - Suction pipe : 2.0-2.5 m/s
  - Low pressure discharge pipe : 2.5-3.0 m/s
  - High pressure discharge pipe : 3.0-3.5 m/s
2. Liquid transport pipeline
  - Water of 1-10 kgf/cm<sup>2</sup>g : 1.5-3 m/s
  - Water of 200-300 kgf/cm<sup>2</sup>g : 3-4 m/s
  - Other types of liquid with high viscosity, like oil : 0.5-2 m/s
3. Compressor
  - Suction pipe : 10-20 m/s
  - Low pressure discharge pipe : 20-30 m/s
  - High pressure discharge pipe : 10-15 m/s
4. Compressing gas transport pipe
  - 1~2kgf/cm<sup>2</sup>g : 8~15m/s
  - 200~300kgf/cm<sup>2</sup>g : 5~7m/s

# Data / Flow Velocity within Pipeline Steam

## Water / steam flow velocity chart

Flow calculation formula

$$Q = \frac{\pi}{4} D^2 \times V \times 3600 \times 10^{-6}$$

$$Q = m^3/h(\text{Flow})$$

A = mm(Nominal diameter of pipeline)  
V = m/s(Flow velocity)

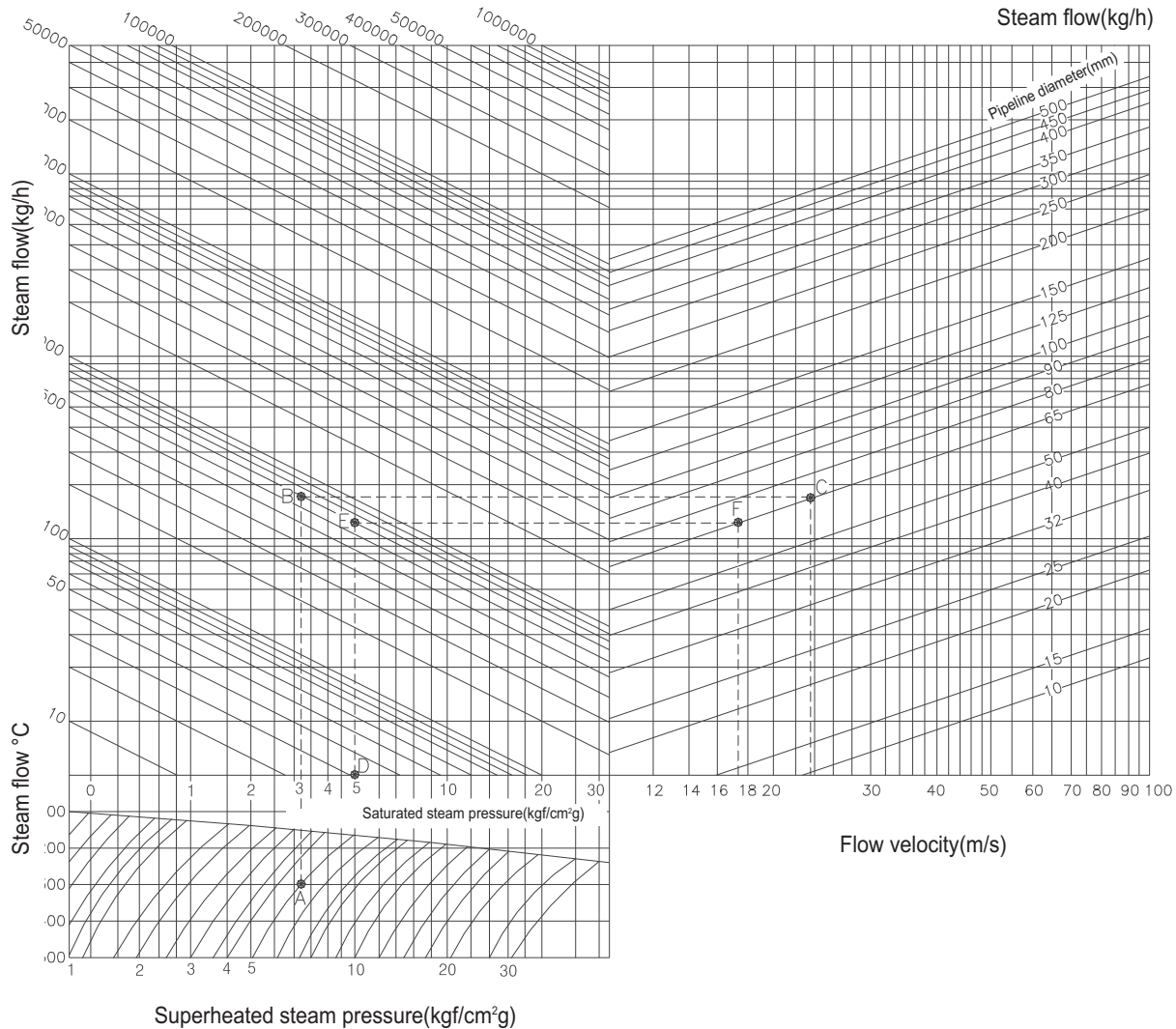

## How to use the chart

Example: To obtain the flow velocity when the steam pressure is 5 kgf/cm<sup>2</sup>g, superheated steam is 300°C, flow is 700 kg/h, and pipeline diameter is 65 mm,

Determine A, the point of intersection between the steam pressure of 5 kgf/cm<sup>2</sup>g and steam temperature of 300°C; and then B, the point of intersection between the flow of 700 kg/h and a vertical line from point A. Afterwards, determine C, the point of intersection between the pipeline diameter of 65 mm and a horizontal line from point B.

Go down vertically from point C, and this line will reach a flow velocity of 23.7 m/s. This is the flow velocity.

When calculating the flow velocity for saturated steam under the same conditions, determine D, which is on the line of saturated steam. Use the same method to follow E and F to read a flow velocity 17.3 m/s.

## Standard flow velocity by use

1. Steam engine
  - Saturated steam : 20-30 m/s
  - Superheated steam : 30-45 m/s
2. Steam transport pipe
  - Saturated steam of 2-5 kgf/cm<sup>2</sup>g : 15-20 m/s
  - Saturated steam of 5-15 kgf/cm<sup>2</sup>g : 20-30 m/s

# Data / Pipeline Head Loss

## ■ Pipeline lengths suitable for different valves (Table 1)

Size (mm)	Appropriate pipeline length (mm)							
	90°C elbow	45°C elbow	90°C T pipe (Branch)	90°C T pipe (Direct)	Gate valve	Ball valve	Angle valve Foot valve	Check valve
15	0.6	0.36	0.9	0.18	0.12	4.5	2.4	1.2
20	0.75	0.45	1.2	0.24	0.15	6.0	3.6	1.6
25	0.95	0.54	1.5	0.27	0.18	7.5	4.5	2.0
32	1.2	0.72	1.8	0.36	0.24	10.5	5.4	2.5
40	1.6	0.9	2.1	0.45	0.3	13.5	7.6	3.1
50	2.1	1.2	3.0	0.6	0.39	16.5	8.4	4.0
65	2.4	1.5	3.6	0.75	0.48	19.5	10.2	4.6
80	3.0	1.8	4.5	0.90	0.63	20.0	12.0	5.7
100	4.2	2.4	6.3	1.20	0.81	37.5	16.5	7.6
125	5.1	3.0	7.5	1.50	0.99	42.0	21.0	10.
150	6.0	3.6	9.0	1.80	1.20	49.5	24.0	12.0
200	6.5	3.7	14.0	4.0	1.40	70.0	33.0	15.0
250	8.0	4.2	20.0	5.0	1.70	90.0	43.0	19.0

## ■ Pipeline friction loss

(Hazen-Williams Equation)  $Q = 1.67Cd^{2.63i^{0.54}} \times 10^4$

Q = Flow (l /min)

C = Flow coefficient (100 in the case of an old cast iron or steel pipeline)

d = Inner diameter of pipeline (m)

i = Pressure loss per unit length (mAq/m)

## ■ Calculation example

In the case of determining all heads that are lost and the pump's lift requirement (20 m), when a steel pipeline with a nominal diameter of 50 (actual length of 36 m) pumps 150 liters of water per minute from a water tank to another water tank (actual lift of 20 m),

## ■ Pipeline head loss chart

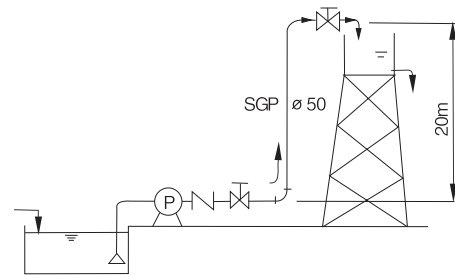
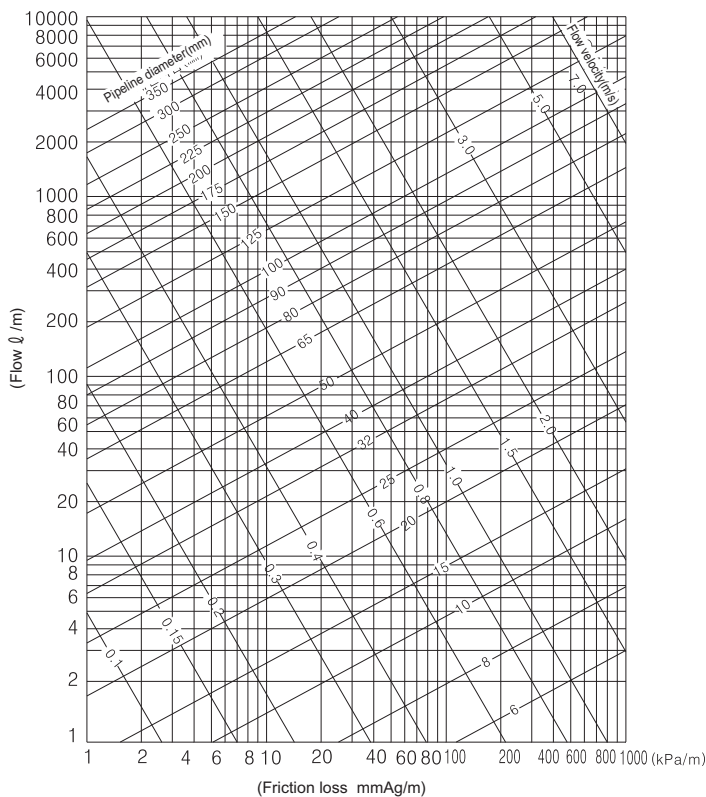

- When determining the pipeline length by Table 1
  - 1 foot valve :  $8.4 \times 1 = 8.4$
  - 1 check valve :  $4.0 \times 1 = 4.0$
  - 2 gate valves :  $0.39 \times 2 = 0.78$
  - 4 elbow pipes :  $2.1 \times 4 = 8.4$
  - Total : 21.58 m
- Obtain the pipeline length by conversion.  
Converted pipeline length =  $36 + 21.58 = 57.58$  m
- Based on the chart, when the nominal diameter is 50 and the flow is 150 l/min, the friction head loss is 52 mmAq/m and all head losses are  $57.58 \times 52 = 2.994$  16mm=3.0.  
The pump's lift requirement is  $20 + 3.0 = 23$  m.

# Data / Generated Condensate Volume of Steam Pipeline

## ■ Generated condensate volume when steam is initially passing through or of a pipeline that has not been insulated

A : When steam is initially passing through kg/mh  
B : Pipeline that has not been insulated kg/mh

Pressure (kg/cm <sup>2</sup> )	Pipeline diameter (mm)	Pipeline diameter (mm)													
		15	20	25	32	40	50	65	80	100	125	150	200	250	300
0.5 (110.7℃)	A	0.04	0.05	0.07	0.09	0.10	0.13	0.22	0.28	0.39	0.52	0.67	1.01	1.42	1.88
	B	0.08	0.10	0.13	0.16	0.18	0.23	0.29	0.33	0.42	0.52	0.61	0.80	0.99	1.17
1 (119.6℃)	A	0.04	0.05	0.07	0.10	0.11	0.15	0.25	0.30	0.43	0.58	0.74	1.11	1.57	2.07
	B	0.09	0.12	0.15	0.18	0.21	0.26	0.32	0.38	0.48	0.59	0.70	0.91	1.12	1.34
2 (132.9℃)	A	0.04	0.06	0.08	0.11	0.13	0.17	0.28	0.34	0.48	0.65	0.83	1.26	1.77	2.33
	B	0.11	0.14	0.18	0.22	0.25	0.31	0.39	0.46	0.58	0.71	0.84	1.10	1.35	1.61
3 (142.9℃)	A	0.05	0.06	0.09	0.12	0.14	0.18	0.30	0.37	0.52	0.71	0.90	1.37	1.93	2.55
	B	0.13	0.16	0.20	0.25	0.29	0.35	0.45	0.52	0.67	0.81	0.96	1.25	1.55	1.85
4 (151.1℃)	A	0.05	0.07	0.09	0.13	0.15	0.19	0.32	0.40	0.56	0.76	0.97	1.47	2.06	2.73
	B	0.14	0.18	0.22	0.28	0.32	0.39	0.50	0.58	0.74	0.90	1.07	1.40	1.72	2.05
5 (158.1℃)	A	0.05	0.07	0.10	0.13	0.16	0.20	0.34	0.42	0.59	0.80	1.02	1.55	2.18	2.88
	B	0.15	0.20	0.25	0.32	0.36	0.45	0.56	0.66	0.84	1.03	1.21	1.59	1.88	2.34
6 (164.2℃)	A	0.06	0.07	0.10	0.14	0.16	0.21	0.36	0.44	0.62	0.84	1.07	1.63	2.29	3.02
	B	0.16	0.21	0.26	0.33	0.37	0.46	0.58	0.68	0.87	1.06	1.26	1.65	2.03	2.43
7 (169.6℃)	A	0.06	0.07	0.11	0.14	0.17	0.22	0.37	0.46	0.65	0.87	1.11	1.69	2.38	3.14
	B	0.18	0.23	0.28	0.35	0.40	0.50	0.62	0.73	0.93	1.14	1.34	1.76	2.17	2.59
8 (174.5)	A	0.06	0.08	0.11	0.15	0.18	0.23	0.38	0.48	0.67	0.91	1.16	1.76	2.47	3.26
	B	0.19	0.24	0.30	0.37	0.42	0.53	0.66	0.77	0.99	1.21	1.28	1.87	2.31	2.76
9 (179.0℃)	A	0.06	0.08	0.12	0.15	0.18	0.24	0.40	0.49	0.70	0.94	1.20	1.82	2.56	3.39
	B	0.20	0.25	0.31	0.39	0.45	0.56	0.70	0.82	1.04	1.27	1.50	1.97	2.44	2.91
10 (183.2℃)	A	0.06	0.08	0.12	0.16	0.19	0.25	0.41	0.51	0.72	0.98	1.24	1.89	2.65	3.51
	B	0.21	0.07	0.33	0.41	0.47	0.58	0.73	0.86	1.09	1.34	1.58	2.07	2.56	3.05
15 (200.4℃)	A	0.07	0.09	0.13	0.18	0.21	0.28	0.46	0.57	0.81	0.09	1.39	2.12	2.98	3.94
	B	0.25	0.32	0.40	0.50	0.57	0.71	0.90	1.05	1.34	1.64	1.93	2.53	3.13	3.73
20 (213.9℃)	A	0.08	0.10	0.14	0.19	0.23	0.30	.50	0.62	0.87	1.18	1.50	2.28	3.21	4.24
	B	0.29	0.26	0.46	0.57	0.65	0.81	1.02	1.19	1.53	1.87	2.21	2.89	3.57	42.6
30 (234.6℃)	A	0.00	0.12	0.17	0.23	0.27	0.35	0.59	0.73	1.03	1.39	1.77	2.69	3.78	5.00
	B	0.37	0.47	0.59	0.74	0.85	1.05	1.32	1.54	1.97	2.41	2.85	3.73	4.61	5.50

## ■ Generated condensate volume when a pipeline is insulated

Temperature (°C)	Pipeline diameter (mm)	Pipeline diameter (mm)													
		15	20	25	32	40	50	65	80	100	125	150	200	250	300
100	Insulation thickness (mm)	15	15	15	15	15	15	15	15	20	20	20	20	20	20
	Condensate volume (kg/mh)	0.05	0.06	0.07	0.08	0.08	0.10	0.11	0.12	0.14	0.17	0.19	0.23	0.27	0.31
150	Insulation thickness (mm)	15	15	20	20	20	20	25	25	25	25	25	25	30	30
	Condensate volume (kg/mh)	0.09	0.10	0.11	0.12	0.13	0.14	0.17	0.18	0.20	0.23	0.26	0.32	0.37	0.42
200	Insulation thickness (mm)	20	20	20	25	25	25	25	25	30	30	30	35	35	35
	Condensate volume (kg/mh)	0.12	0.14	0.15	0.15	0.17	0.19	0.22	0.24	0.28	0.32	0.36	0.43	0.50	0.58
250	Insulation thickness (mm)	20	25	25	25	25	30	30	30	35	35	35	40	40	40
	Condensate volume (kg/mh)	0.17	1.19	0.20	0.22	0.23	0.26	0.30	0.33	0.38	0.43	0.49	0.58	0.68	0.78
300	Insulation thickness (mm)	25	25	25	30	30	30	35	35	40	40	40	45	45	45
	Condensate volume (kg/mh)	0.22	0.25	0.28	0.30	0.33	0.37	0.42	0.46	0.53	0.60	0.68	0.80	0.94	1.08



# Data / Dimensions Table of Carbon Steel Pipe

The following is what is prescribed by KS D3507 and KS D3562 for carbon steel pipes used for pipelines.

A carbon steel pipe for ordinary piping (SPP) is used for pipelines with a comparatively low running pressure, including pipelines for steam, water, oil, gas, and air; and a carbon steel pipe for pressure service (SPPS) is used for pressure pipelines used at 350°C or lower.

Size		Outer diameter (mm)	SPP			SPPS											
			Thickness (mm)	Weight without a socket (kg/m)	Nominal thickness												
					Schedule 40				Schedule 60				Schedule 60				
					Thickness (mm)	Weight (kg/m)	Water pressure test pressure (kg/m)		Thickness (mm)	Weight (kg/m)	Pressure of hydro-pressure test (kg/m)		Thickness (mm)	Weight (kg/m)	Pressure of hydro-pressure test (kg/m)		
Type 2	Type 3	Type 2	Type 3	Type 2			Type 3										
(A)	(B)																
6	1/8	10.5	2.0	0.419	1.7	0.369	50	50	2.2	0.450	70	70	2.4	0.479	70	70	
8	1/4	13.8	2.3	0.652	2.2	0.629	50	50	2.4	0.675	70	70	3.0	0.799	70	70	
10	3/8	17.3	2.3	0.851	2.3	0.851	50	50	2.8	1.00	70	70	3.2	1.11	70	70	
15	1/2	21.7	2.8	1.31	2.8	1.31	50	50	3.2	0.46	70	70	3.7	1.64	70	70	
20	3/4	27.2	2.8	1.68	2.9	1.74	50	50	3.4	2.00	70	70	3.9	2.24	70	70	
25	1	34.0	3.2	2.43	3.4	2.57	50	50	3.9	2.89	70	70	4.5	3.27	70	70	
32	1 1/4	42.7	3.5	3.38	3.6	3.47	70	50	4.5	4.24	100	120	4.5	4.57	140	130	
40	1 1/2	48.6	3.5	3.89	3.7	4.10	70	50	4.5	4.89	100	120	5.1	5.47	140	130	
50	2	60.5	3.8	5.31	3.9	5.44	70	50	4.9	6.72	100	120	5.5	7.46	140	130	
65	2 1/2	76.3	4.2	7.47	5.2	9.12	70	50	6.0	10.4	100	120	7.0	12.0	140	130	
80	3	89.1	4.2	8.79	5.5	11.3	70	50	6.6	13.4	130	140	7.6	115.3	180	180	
90	3 1/2	101.6	4.2	10.1	5.7	13.5	100	100	7.0	16.3	140	130	8.1	18.7	180	180	
100	4	114.3	4.5	12.2	6.0	16.0	100	100	7.1	18.8	140	140	8.6	22.4	180	180	
125	5	139.8	4.5	15.0	6.6	21.7	100	100	8.1	26.3	140	140	9.5	30.5	180	180	
150	6	165.2	5.0	19.8	7.1	28.7	100	100	9.3	35.8	140	140	11.0	14.8	180	180	
200	8	216.3	5.8	30.1	8.2	42.1	100	100	10.3	52.3	130	140	12.7	63.8	170	160	
250	10	267.4	6.6	42.4	9.3	59.2	100	100	12.7	79.8	130	140	15.1	93.9	170	150	
300	12	318.5	6.9	53.0	10.3	78.3	100	100	14.3	107	120	130	17.4	129	160	140	
350	14	355.5	7.9	67.7	11.1	94.3	70	100	15.1	127	110	130	19.0	158	160	140	
400	16	406.4	7.9	77.6	12.7	123	70	100	16.7	160	110	120	21.4	203	160	140	

# Data / Pressure stage table of iron / steel pipe flange

KSM 1501 (Pressure stage of iron/steel pipe flange) sets forth the following regulations concerning the maximum running pressure, based on the nominal pressure, materials, and fluid state of iron/steel pipe flanges used for pipelines for steam, Air, Gas, Water, Oil, Etc.

Nominal pressure	Material	Fluid state and maximum running pressure										Pressure of hydro-pressure test (Reference)
		Fluid state										
		W 120°C or lower	G <sub>1</sub> 220°C or lower	G <sub>2</sub> 350°C	G <sub>3</sub> 350°C	H <sub>1</sub> 400°C	H <sub>2</sub> 425°C	H <sub>3</sub> 450°C	H <sub>4</sub> 475°C	H <sub>5</sub> 490°C		
2	FC 200	3	5	—	—	—	—	—	—	—	—	4
	FCMB35	3	6	—	—	—	—	—	—	—	—	
5	SS41, SF40, S20C, SC42, SCPH1	7	6	—	—	—	—	—	—	—	—	10
	FC 200	7	10	5	—	—	—	—	—	—	—	
10	FCM35	14	12	—	—	—	—	—	—	—	—	20
	SS41, SF40, S20C, SC42, SCPH1	14	12	10	—	—	—	—	—	—	—	
16	FC 200	22	16	—	—	—	—	—	—	—	—	32
	FCMB35	27	20	18	16	—	—	—	—	—	—	35
	SS41(2), SF44, SFV1, S20C, SC25, SC49(2), SCPH2	28	25	23	21	18	16	—	—	—	—	40
20	FCM35	28	25	—	20	—	—	—	—	—	—	44
	SS41(2), SF45, SFVIS20C, S25C, SC49(2), SCPH	34	31	29	26	23	20	—	—	—	—	50
30	SF45, S25C, SFV1, SC49(2)SCPH2	51	46	43	39	34	30	—	—	—	—	75
	SCPH11, SFHV12B	(51)	(46)	(43)	(39)	38	36	34	30(4)	—	—	
	SCPH21, SFHV23B	(51)	(46)	(43)	(39)	(38)	(36)	(34)	32	30	—	

FC20	KS D 4301	JIS G 5501
FCMB35	KS D 4303	JIS G 5702
SS41	KS D 3503	JIS G 3101
SF40, SF45	KS D 3710	JIS G 3201
SFV1	KS D 4109	JIS G 3211
SFHV12B, SFHV23B	KS D 4100	JIS G 3213
S20C, S25C	KS D 3752	JIS G 4051
SC42, SC49	KS D 4101	JIS G 5101
SCPH1, SCPH2	KS D 4315	JIS G 5151
SCPH11, SCPH21		

Notes : (1) Select a material from the nominal pressure step table or that satisfies the required flange performance.

(2) Apply to a maximum running temperature of 350 °C

(3) There is the possibility of SCPH 11 and 1/2 Mo forged steel resulting in ductile fracture, and therefore should not be used at a temperature of 450 °C or higher.

(4) The 'pressure of hydro-pressure test' lists test pressure levels for reference in case of installation of a flange in a pipeline. Exceptions are separately regulated.

Notes : 1. W is applied only to running water with almost no flow (with little pressure fluctuation) and with a temperature of 120 °C or lower.

2. G<sub>1</sub>, G<sub>2</sub>, and G<sub>3</sub> are applied to water with pressure fluctuations or steam, gas, and oil of the corresponding temperature regulated above.

3. H<sub>1</sub> is applied to steam, air, gas, oil, etc. of 400 °C

4. If the temperature or pressure is in the middle of the table above, the maximum running pressure or temperature can be determined based on interpolation.

5. H<sub>2</sub> through H<sub>4</sub> are applied to steam, air, gas, oil, etc. of 425 to 510°C. They are applied when there is a need to consider a material creep because of high temperature.

6. When shock, corrosion, or other special conditions are accompanied, apply a maximum running pressure that corresponds to a higher temperature or that of a higher nominal pressure.

7. The values in parentheses are generally not used, but are specified for reference.

8. When there is a need to indicate a fluid's state using a symbol, use W through H<sub>4</sub>.

# Data / Standard Dimensions of Flange

## Standard dimensions of a 5 kgf/cm<sup>2</sup> pipe flange

(KS B 1511 - 1987)  
(JIS B 2210 - 1987)

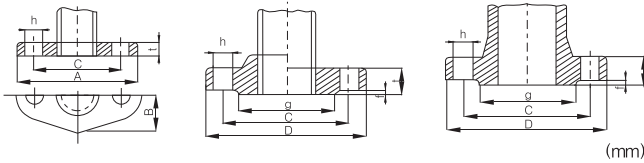

Size	Outer diameter of applied steel pipe	Outer diameter of flange D	Dimensions of each part of flange					Bolt hole			Nominal diameter of bolt screw (name)
			t		f	Diameter (g)	Diameter of center circle (c)	Number	Diameter (h)		
			Other than grey cast iron	Grey cast iron							
10	17.3	75(75×45)	9	12	1	39	55	4(2)	12	M10	
15	21.7	80(80×50)	9	12	1	44	60	4(2)	12	M10	
20	27.2	85	10	14	1	49	65	4	12	M10	
25	34.0	95	10	14	1	59	75	4	12	M10	
32	42.7	115	12	16	2	70	90	4	15	M12	
40	48.6	120	12	16	2	75	95	4	15	M12	
50	60.5	130	14	16	2	85	105	4	15	M12	
65	76.3	155	14	18	2	110	130	4	15	M12	
80	89.1	180	14	18	2	121	145	4	19	M16	
(90)	101.6	190	14	18	2	131	155	4	19	M16	
100	114.3	200	16	20	2	141	165	8	19	M16	
125	139.8	235	16	20	2	176	200	8	19	M16	
150	165.2	265	18	22	2	216	230	8	19	M16	
(175)	190.7	300	18	22	2	232	260	8	23	M20	
200	216.3	320	20	24	2	252	280	8	23	M20	
(225)	241.8	345	20	24	2	277	305	12	23	M20	
250	267.4	385	22	26	2	317	345	12	23	M20	
300	318.5	430	22	28	3	360	390	12	23	M20	
350	355.6	480	24	30	3	403	435	12	25	M22	
400	406.4	540	24	30	3	463	495	16	25	M22	
450	457.2	605	24	30	3	523	555	16	25	M22	
500	508.0	655	24	32	3	573	605	20	25	M22	

## Standard dimensions of a 10 kgf/cm<sup>2</sup> pipe flange

(KS B 1511 - 1987)  
(JIS B 2210 - 1987)

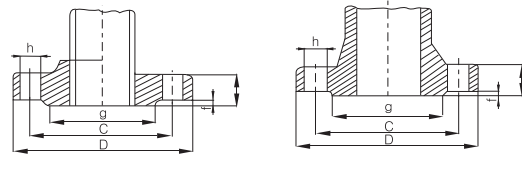

Size	Outer diameter of applied steel pipe	Outer diameter of flange D	Dimensions of each part of flange					Bolt hole			Nominal diameter of bolt screw (name)
			t		f	Diameter (g)	Diameter of center circle (c)	Number	Diameter (h)		
			Other than grey cast iron	Grey cast iron							
10	17.3	90	12	14	1	46	65	4	15	M12	
15	21.7	95	12	16	1	51	70	4	15	M12	
20	27.2	100	14	18	1	56	75	4	15	M12	
25	34.0	125	14	18	1	67	90	4	19	M16	
32	42.7	135	16	20	2	76	100	4	19	M16	
40	48.6	140	16	20	2	81	105	4	19	M16	
50	60.5	155	16	20	2	95	120	4	19	M16	
65	76.3	175	18	22	2	116	140	4	19	M16	
80	89.1	185	18	22	2	126	150	8	19	M16	
(90)	101.6	195	18	22	2	136	160	8	19	M16	
100	114.3	210	18	24	2	151	175	8	19	M16	
125	139.8	250	20	24	2	182	210	8	23	M20	
150	165.2	280	22	26	2	212	240	8	23	M20	
(175)	190.7	305	22	26	2	237	265	12	23	M20	
200	216.3	330	22	26	2	262	290	12	23	M20	
(225)	241.8	350	22	28	2	282	310	12	23	M20	
250	267.4	400	24	30	2	324	355	12	25	M22	
300	318.5	445	24	32	3	368	400	16	25	M22	
350	355.6	490	26	34	3	413	445	16	25	M22	
400	406.4	560	28	36	3	475	510	16	27	M24	
450	457.2	620	30	38	3	530	565	20	27	M24	
500	508.0	675	30	40	3	585	620	20	27	M24	

## Standard dimensions of a 16 kgf/cm<sup>2</sup> pipe flange

(KS B 1511 - 1987)  
(JIS B 2210 - 1987)

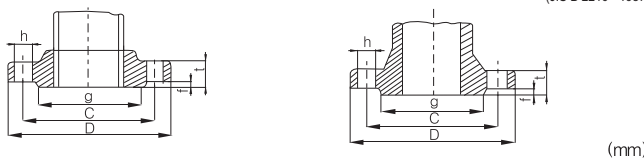

Size	Outer diameter of applied steel pipe	Outer diameter of flange D	Dimensions of each part of flange					Bolt hole			Nominal diameter of bolt screw (name)
			t		f	Diameter (g)	Diameter of center circle (c)	Number	Diameter (h)		
			Other than grey cast iron	Grey cast iron							
10	17.3	90	12	—	1	41	65	4	15	M12	
15	21.7	95	12	—	1	51	70	4	15	M12	
20	27.2	100	14	—	1	56	75	4	15	M12	
25	34.0	125	14	—	1	67	90	4	19	M16	
32	42.7	135	16	—	2	76	100	4	19	M16	
40	48.6	140	16	—	2	81	105	4	19	M16	
50	60.5	155	16	20	2	96	120	8	19	M16	
65	76.3	175	18	22	2	116	140	8	19	M16	
80	89.1	200	20	24	2	132	160	8	23	M20	
(90)	101.6	210	20	24	2	145	170	8	23	M20	
100	114.3	225	22	26	2	160	185	8	23	M20	
125	139.8	270	22	26	2	195	225	8	25	M22	
150	165.2	305	24	28	2	230	260	12	25	M22	
200	216.3	350	26	30	2	275	305	12	25	M22	
250	267.4	430	28	34	2	345	380	12	27	M24	
300	318.5	480	30	36	3	395	430	16	27	M24	
350	355.6	540	34	38	3	440	480	16	33	M30×3	
400	406.4	605	38	42	3	495	540	16	33	M30×3	
450	457.2	675	40	46	3	560	605	20	33	M30×3	
500	508.0	730	42	50	3	615	660	20	33	M30×3	

## Standard dimensions of a 20 kgf/cm<sup>2</sup> pipe flange

(KS B 1511 - 1987)  
(JIS B 2210 - 1987)

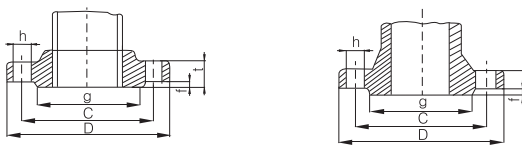

Size	Outer diameter of applied steel pipe	Outer diameter of flange D	Dimensions of each part of flange					Bolt hole			Nominal diameter of bolt screw (name)
			t		f	Diameter (g)	Diameter of center circle (c)	Number	Diameter (h)		
			Other than grey cast iron	Grey cast iron							
10	17.3	90	14	16	1	46	65	4	15	M12	
15	21.7	95	14	16	1	51	70	4	15	M12	
20	27.2	100	16	18	1	56	75	4	15	M12	
25	34.0	125	16	20	1	67	90	4	19	M16	
32	42.7	135	18	20	2	76	100	4	19	M16	
40	48.6	140	18	22	2	81	105	4	19	M16	
50	60.5	155	18	22	2	96	120	8	19	M16	
65	76.3	175	20	24	2	116	140	8	19	M16	
80	89.1	200	22	26	2	132	160	8	23	M20	
(90)	101.6	210	24	28	2	145	170	8	23	M20	
100	114.3	225	24	28	2	160	185	8	23	M20	
125	139.8	270	26	30	2	195	225	8	25	M22	
150	165.2	305	28	32	2	230	260	12	25	M22	
200	216.3	350	30	34	2	275	305	12	25	M22	
250	267.4	430	34	38	2	345	380	12	27	M24	
300	318.5	480	36	40	3	395	430	16	27	M24	
350	355.6	540	40	44	3	440	480	16	33	M30×3	
400	406.4	605	46	50	3	495	540	16	33	M30×3	
450	457.2	675	48	54	3	560	605	20	33	M30×3	
500	508.0	730	50	58	3	615	660	20	33	M30×3	



# Data / Standard Dimensions of Flange

## Standard dimensions of a 30 kgf/cm<sup>2</sup> pipe flange

(KS B 1511 - 1987)  
(JIS B 2210 - 1987)

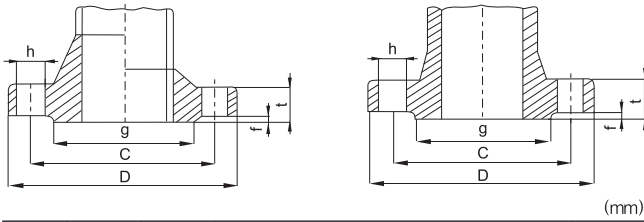

Size	Outer diameter of applied steel pipe	Outer diameter of flange D	Dimensions of each part of flange				Bolt hole			Nominal diameter of bolt screw
			t	f	Diameter (g)	Diameter of center circle (c)	Number	Diameter (h)		
10	17.3	110	16	1	52	75	4	19	M16	
15	21.7	115	18	1	55	80	4	19	M16	
20	27.2	120	18	1	60	85	4	19	M16	
25	34.0	130	20	1	70	95	4	19	M16	
32	42.7	140	22	2	80	105	4	19	M16	
40	48.6	160	22	2	90	120	4	23	M16	
50	60.5	165	22	2	105	130	8	19	M20	
65	76.3	200	26	2	130	160	8	23	M20	
80	89.1	210	28	2	140	170	8	23	M20	
(90)	101.6	230	30	2	150	185	8	25	M22	
100	114.3	240	32	2	160	195	8	25	M22	
125	139.8	275	36	2	195	230	8	25	M22	
150	165.2	325	38	2	235	275	12	27	M24	
200	216.3	370	42	2	280	320	12	27	M24	
250	267.4	450	48	2	345	390	12	33	M30×3	
300	318.5	515	52	3	405	450	16	33	M30×3	
350	355.6	560	54	3	450	495	16	33	M30×3	
400	406.4	630	60	3	510	560	16	39	M36×3	

## Standard dimensions of a 40 kgf/cm<sup>2</sup> pipe flange

(KS B 1511 - 1987)  
(JIS B 2210 - 1987)

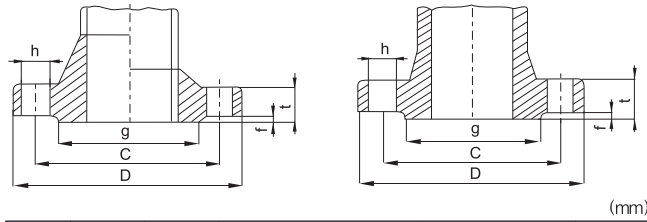

Size	Outer diameter of applied steel pipe	Outer diameter of flange D	Dimensions of each part of flange				Bolt hole			Nominal diameter of bolt screw
			t	f	Diameter (g)	Diameter of center circle (c)	Number	Diameter (h)		
10	17.3	110	18	1	52	75	4	19	M16	
15	21.7	115	20	1	55	80	4	19	M16	
20	27.2	120	20	1	60	85	4	19	M16	
25	34.0	130	22	1	70	95	4	19	M16	
32	42.7	140	24	2	80	105	4	19	M16	
40	48.6	160	24	2	90	120	4	23	M16	
50	60.5	165	26	2	105	130	8	19	M20	
65	76.3	200	30	2	130	160	8	23	M20	
80	89.1	210	32	2	140	170	8	23	M20	
(90)	101.6	230	34	2	150	185	8	25	M22	
100	114.3	250	36	2	165	205	8	25	M22	
125	139.8	300	40	2	200	250	8	27	M24	
150	165.2	355	44	2	240	295	12	33	M30×3	
200	216.3	405	50	2	290	345	12	33	M30×3	
250	267.4	475	56	2	355	410	12	33	M30×3	
300	318.5	540	60	3	410	470	16	39	M36×3	
350	355.6	585	64	3	455	515	16	39	M36×3	
400	406.4	645	70	3	515	570	16	39	M36×3	

## Standard dimensions of an ANSI 125 POUND cast iron pipe flange

## Standard dimensions of an ANSI 150 POUND steel pipe flange

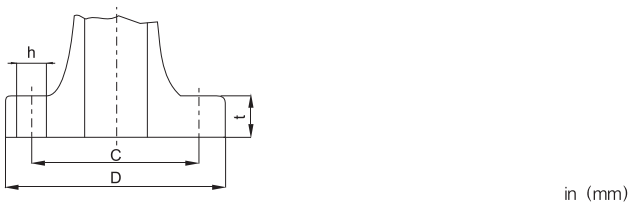

Size		Outer diameter of flange D	Thickness (t)	Bolt hole			Nominal diameter of bolt screw
in	(mm)			Center diameter (c)	Number	Diameter (h)	
1	25	4 1/4 (108)	1 1/16 (11.2)	3 1/8 (79.5)	4	5/8 (16)	1/2
1 1/4	32	4 5/8 (117)	3/4 (12.7)	3 1/2 (89.0)	4	5/8 (16)	1/2
1 1/2	40	5 (127)	13/16 (14.3)	3 7/8 (98.5)	4	5/8 (16)	1/2
2	50	6 (152)	7/8 (15.9)	4 3/4 (120.5)	4	3/4 (19)	1/2
2 1/2	65	7 (178)	1 (17.5)	5 1/2 (139.5)	4	3/4 (19)	5/8
3	80	7 1/2 (191)	1 1/8 (19.1)	6 (152.5)	4	3/4 (19)	5/8
3 1/2	90	8 1/2 (216)	1 3/16 (22.3)	7 (178.0)	8	3/4 (19)	5/8
4	100	9 (229)	1 1/4 (23.9)	7 1/2 (190.5)	8	3/4 (19)	5/8
5	125	10 (254)	1 3/8 (23.9)	8 1/2 (216.0)	8	7/8 (22)	3/4
6	150	11 (279)	1 7/16 (25.4)	9 1/2 (241.5)	8	7/8 (22)	3/4
8	200	13 1/2 (343)	1 5/8 (28.6)	11 3/4 (298.5)	8	7/8 (22)	3/4
10	250	16 (406)	1 7/8 (30.2)	14 1/4 (362.0)	12	1 (25)	7/8
12	300	19 (483)	2 (31.8)	17 (432.0)	12	1 (25)	7/8
14	350	21 (533)	2 1/8 (35.0)	18 3/4 (476.0)	12	1 1/8 (29)	1
16	400	23 1/2 (597)	2 1/4 (36.6)	21 1/4 (539.5)	12	1 1/8 (29)	1

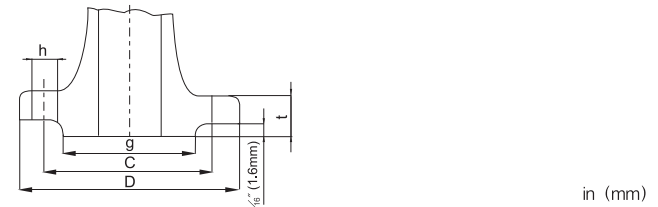

Size		Outer diameter of flange D	Thickness (t)	diameter (h)	Bolt hole			Nominal diameter of bolt screw
in	(mm)				Center diameter (c)	Number	Diameter (h)	
1/2	15	3 1/2 (89)	7/16 (11.2)	1 3/8 (35)	2 3/8 (60.5)	4	5/8 (16)	1/2
3/4	20	3 7/8 (98)	1/2 (12.7)	1 11/16 (43)	2 3/4 (70.0)	4	5/8 (16)	1/2
1	25	4 1/4 (108)	9/16 (14.3)	2 (51)	3 3/8 (79.5)	4	5/8 (16)	1/2
1 1/4	32	4 5/8 (117)	5/8 (15.9)	2 1/2 (64)	3 1/2 (89.0)	4	5/8 (16)	1/2
1 1/2	40	5 (127)	1 1/16 (17.5)	2 7/8 (73)	3 7/8 (98.5)	4	5/8 (16)	1/2
2	50	6 (152)	3/4 (19.1)	3 3/8 (92)	4 3/4 (120.5)	4	3/4 (19)	5/8
2 1/2	65	7 1/2 (178)	7/8 (22.3)	4 1/8 (105)	5 1/2 (139.5)	4	3/4 (19)	5/8
3	80	7 1/2 (191)	1 5/16 (23.9)	5 (127)	6 (152.5)	4	3/4 (19)	5/8
3 1/2	90	8 1/2 (216)	1 5/16 (23.9)	5 1/2 (140)	7 (178.0)	8	3/4 (19)	5/8
4	100	9 (229)	1 5/16 (23.9)	6 3/16 (157)	7 1/2 (190.5)	8	3/4 (19)	5/8
5	125	10 (254)	1 5/16 (23.9)	7 7/16 (186)	8 1/2 (216.0)	8	7/8 (22)	5/8
6	150	11 (279)	1 (25.4)	8 1/2 (216)	9 1/2 (241.5)	8	7/8 (22)	3/4
8	200	13 1/2 (343)	1 1/8 (28.6)	10 5/8 (270)	11 3/4 (298.5)	8	7/8 (22)	3/4
10	250	16 (406)	1 3/8 (30.2)	12 3/4 (324)	14 1/4 (362.0)	12	1 (25)	7/8
12	300	19 (483)	1 1/4 (31.8)	15 (381)	17 (432.0)	12	1 (25)	7/8
14	350	21 (533)	1 3/8 (35.0)	16 1/4 (413)	18 3/4 (476.0)	12	1 1/8 (29)	1
16	400	23 1/2 (597)	1 7/8 (36.6)	18 1/2 (470)	21 1/4 (539.5)	16	1 1/8 (29)	1

# Data / Standard Dimensions of Flange

## Standard dimensions of an ANSI 250 POUND cast iron pipe flange

in (mm)

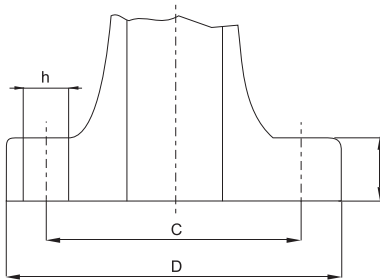

Size		Outer diameter of flange D	Thickness (t)	diameter (h)	Bolt hole			Nominal diameter of bolt
in	(mm)				Center diameter (c)	Number	Diameter (h)	
1	25	4 <sup>7</sup> / <sub>8</sub> (124)	1 <sup>1</sup> / <sub>16</sub> (17.5)	2 <sup>1</sup> / <sub>16</sub> ( 68.5)	3 <sup>1</sup> / <sub>2</sub> ( 89)	4	3 <sup>4</sup> / <sub>8</sub> (19)	5 <sup>8</sup> / <sub>16</sub>
1 <sup>1</sup> / <sub>4</sub>	32	5 <sup>1</sup> / <sub>4</sub> (133)	3 <sup>4</sup> / <sub>8</sub> (19.1)	3 <sup>1</sup> / <sub>16</sub> ( 78.0)	3 <sup>7</sup> / <sub>8</sub> ( 98)	4	3 <sup>4</sup> / <sub>8</sub> (19)	5 <sup>8</sup> / <sub>16</sub>
1 <sup>1</sup> / <sub>2</sub>	40	6 <sup>1</sup> / <sub>8</sub> (156)	1 <sup>3</sup> / <sub>16</sub> (21.0)	3 <sup>9</sup> / <sub>16</sub> ( 90.5)	4 <sup>1</sup> / <sub>2</sub> (114)	4	7 <sup>7</sup> / <sub>8</sub> (22)	3 <sup>4</sup> / <sub>8</sub>
2	50	6 <sup>1</sup> / <sub>2</sub> (165)	7 <sup>8</sup> / <sub>16</sub> (22.3)	4 <sup>3</sup> / <sub>16</sub> (106.5)	5 (127)	4	3 <sup>4</sup> / <sub>8</sub> (19)	5 <sup>8</sup> / <sub>16</sub>
2 <sup>1</sup> / <sub>2</sub>	65	7 <sup>1</sup> / <sub>2</sub> (191)	1 (25.4)	4 <sup>9</sup> / <sub>16</sub> (125.5)	5 <sup>7</sup> / <sub>8</sub> (149)	4	7 <sup>7</sup> / <sub>8</sub> (22)	3 <sup>4</sup> / <sub>8</sub>
3	80	8 <sup>1</sup> / <sub>4</sub> (210)	1 <sup>1</sup> / <sub>8</sub> (23.6)	5 <sup>1</sup> / <sub>16</sub> (144.5)	6 <sup>7</sup> / <sub>8</sub> (168)	8	7 <sup>7</sup> / <sub>8</sub> (22)	3 <sup>4</sup> / <sub>8</sub>
3 <sup>1</sup> / <sub>2</sub>	90	9 (229)	1 <sup>3</sup> / <sub>16</sub> (30.2)	6 <sup>5</sup> / <sub>16</sub> (160.5)	7 <sup>1</sup> / <sub>4</sub> (184)	8	7 <sup>7</sup> / <sub>8</sub> (22)	3 <sup>4</sup> / <sub>8</sub>
4	150	10 (254)	1 <sup>1</sup> / <sub>4</sub> (31.8)	6 <sup>5</sup> / <sub>16</sub> (176.5)	7 <sup>7</sup> / <sub>8</sub> (200)	8	7 <sup>7</sup> / <sub>8</sub> (22)	3 <sup>4</sup> / <sub>8</sub>
5	125	11 (279)	1 <sup>3</sup> / <sub>8</sub> (35.0)	8 <sup>5</sup> / <sub>16</sub> (211.5)	9 <sup>1</sup> / <sub>4</sub> (235)	8	7 <sup>7</sup> / <sub>8</sub> (22)	3 <sup>4</sup> / <sub>8</sub>
6	150	12 <sup>1</sup> / <sub>2</sub> (318)	1 <sup>7</sup> / <sub>8</sub> (36.6)	9 <sup>1</sup> / <sub>16</sub> (246.5)	10 <sup>5</sup> / <sub>8</sub> (270)	8	7 <sup>7</sup> / <sub>8</sub> (22)	3 <sup>4</sup> / <sub>8</sub>
8	200	15 (381)	1 <sup>5</sup> / <sub>8</sub> (41.3)	11 <sup>1</sup> / <sub>16</sub> (303.5)	13 (330)	12	1 (25)	7 <sup>8</sup> / <sub>16</sub>
10	250	17 <sup>1</sup> / <sub>2</sub> (445)	1 <sup>7</sup> / <sub>8</sub> (47.6)	14 <sup>1</sup> / <sub>16</sub> (357.5)	15 <sup>1</sup> / <sub>4</sub> (387)	12	1 <sup>1</sup> / <sub>4</sub> (29)	1
12	300	20 (521)	2 (50.8)	16 <sup>7</sup> / <sub>8</sub> (418.0)	17 <sup>3</sup> / <sub>4</sub> (451)	16	1 <sup>1</sup> / <sub>4</sub> (32)	1 <sup>1</sup> / <sub>8</sub>
14	350	23 (584)	2 <sup>1</sup> / <sub>8</sub> (54.0)	18 <sup>3</sup> / <sub>8</sub> (481.5)	20 <sup>1</sup> / <sub>4</sub> (514)	16	1 <sup>1</sup> / <sub>4</sub> (32)	1 <sup>1</sup> / <sub>8</sub>
16	400	25 <sup>1</sup> / <sub>2</sub> (648)	2 <sup>1</sup> / <sub>4</sub> (57.2)	21 <sup>1</sup> / <sub>16</sub> (535.0)	22 <sup>1</sup> / <sub>2</sub> (572)	20	1 <sup>3</sup> / <sub>8</sub> (35)	1 <sup>1</sup> / <sub>4</sub>

## Standard dimensions of an ANSI 300 POUND cast iron pipe flange

in (mm)

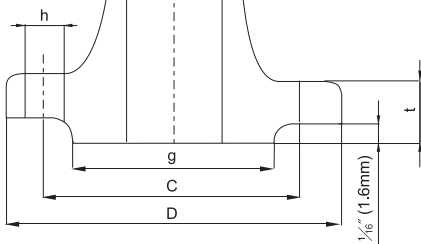

Size		Outer diameter of flange D	Thickness (t)	diameter (h)	Bolt hole			Nominal diameter of bolt
in	(mm)				Center diameter (c)	Number	Diameter (h)	
1/2	15	3 <sup>3</sup> / <sub>4</sub> ( 59)	9 <sup>16</sup> / <sub>16</sub> (14.3)	1 <sup>3</sup> / <sub>8</sub> ( 35)	2 <sup>5</sup> / <sub>8</sub> ( 66.5)	4	5 <sup>8</sup> / <sub>16</sub> (16)	1/2
3/4	20	4 <sup>5</sup> / <sub>8</sub> (117)	5 <sup>8</sup> / <sub>16</sub> (15.9)	1 <sup>1</sup> / <sub>16</sub> ( 43)	3 <sup>1</sup> / <sub>4</sub> ( 82.5)	4	3 <sup>4</sup> / <sub>8</sub> (19)	5/8
1	25	4 <sup>7</sup> / <sub>8</sub> (124)	1 <sup>1</sup> / <sub>16</sub> (17.5)	2 ( 51)	3 <sup>1</sup> / <sub>2</sub> ( 89.0)	4	3 <sup>4</sup> / <sub>8</sub> (19)	5/8
1 <sup>1</sup> / <sub>4</sub>	32	5 <sup>1</sup> / <sub>4</sub> (133)	3 <sup>4</sup> / <sub>8</sub> (19.1)	2 <sup>1</sup> / <sub>2</sub> ( 64)	3 <sup>7</sup> / <sub>8</sub> ( 98.5)	4	3 <sup>4</sup> / <sub>8</sub> (19)	5/8
1 <sup>1</sup> / <sub>2</sub>	40	6 <sup>1</sup> / <sub>8</sub> (156)	1 <sup>3</sup> / <sub>16</sub> (20.7)	2 <sup>7</sup> / <sub>8</sub> ( 73)	4 <sup>1</sup> / <sub>2</sub> (114.5)	4	7 <sup>7</sup> / <sub>8</sub> (22)	3 <sup>4</sup> / <sub>8</sub>
2	50	6 <sup>1</sup> / <sub>2</sub> (165)	7 <sup>8</sup> / <sub>16</sub> (22.3)	3 <sup>5</sup> / <sub>8</sub> ( 92)	5 (127.0)	8	3 <sup>4</sup> / <sub>8</sub> (19)	5/8
2 <sup>1</sup> / <sub>2</sub>	65	7 <sup>1</sup> / <sub>2</sub> (191)	1 (25.4)	4 <sup>1</sup> / <sub>8</sub> (105)	5 <sup>7</sup> / <sub>8</sub> (149.0)	8	7 <sup>7</sup> / <sub>8</sub> (22)	3 <sup>4</sup> / <sub>8</sub>
3	80	8 <sup>1</sup> / <sub>4</sub> (210)	1 <sup>1</sup> / <sub>8</sub> (28.6)	5 (127)	6 <sup>5</sup> / <sub>8</sub> (168.0)	8	7 <sup>7</sup> / <sub>8</sub> (22)	3 <sup>4</sup> / <sub>8</sub>
3 <sup>1</sup> / <sub>2</sub>	90	9 (229)	1 <sup>3</sup> / <sub>16</sub> (30.2)	5 <sup>1</sup> / <sub>2</sub> (140)	7 <sup>1</sup> / <sub>4</sub> (184.0)	8	7 <sup>7</sup> / <sub>8</sub> (22)	3 <sup>4</sup> / <sub>8</sub>
4	100	10 (254)	1 <sup>1</sup> / <sub>4</sub> (31.8)	6 <sup>5</sup> / <sub>16</sub> (157)	7 <sup>7</sup> / <sub>8</sub> (200.0)	8	7 <sup>7</sup> / <sub>8</sub> (22)	3 <sup>4</sup> / <sub>8</sub>
5	125	11 (279)	1 <sup>3</sup> / <sub>8</sub> (35.0)	7 <sup>5</sup> / <sub>16</sub> (186)	9 <sup>1</sup> / <sub>4</sub> (235.0)	8	7 <sup>7</sup> / <sub>8</sub> (22)	3 <sup>4</sup> / <sub>8</sub>
6	150	12 <sup>1</sup> / <sub>2</sub> (318)	1 <sup>7</sup> / <sub>8</sub> (36.6)	8 <sup>1</sup> / <sub>2</sub> (216)	10 <sup>5</sup> / <sub>8</sub> (270.0)	12	7 <sup>7</sup> / <sub>8</sub> (22)	3 <sup>4</sup> / <sub>8</sub>
8	200	15 (381)	1 <sup>5</sup> / <sub>8</sub> (41.3)	10 <sup>5</sup> / <sub>8</sub> (270)	13 (330.0)	12	1 (25)	7/8
10	250	17 <sup>1</sup> / <sub>2</sub> (445)	1 <sup>7</sup> / <sub>8</sub> (47.7)	12 <sup>3</sup> / <sub>4</sub> (324)	15 <sup>1</sup> / <sub>4</sub> (387.5)	16	1 <sup>1</sup> / <sub>8</sub> (29)	1
12	300	20 <sup>1</sup> / <sub>2</sub> (521)	2 (50.8)	15 (381)	17 <sup>3</sup> / <sub>4</sub> (451.0)	16	1 <sup>1</sup> / <sub>4</sub> (32)	1 <sup>1</sup> / <sub>8</sub>
14	350	23 (584)	2 <sup>1</sup> / <sub>8</sub> (54.0)	16 <sup>1</sup> / <sub>4</sub> (413)	20 <sup>1</sup> / <sub>4</sub> (514.5)	20	1 <sup>1</sup> / <sub>4</sub> (32)	1 <sup>1</sup> / <sub>8</sub>
16	400	25 <sup>1</sup> / <sub>2</sub> (648)	2 <sup>1</sup> / <sub>4</sub> (57.2)	18 <sup>1</sup> / <sub>2</sub> (470)	22 <sup>1</sup> / <sub>2</sub> (571.5)	20	1 <sup>3</sup> / <sub>8</sub> (35)	1 <sup>1</sup> / <sub>4</sub>



---

## Product Warranty

Samsung Valve products have been manufactured based on advanced technology, perfect quality control, and strict inspections. In order to address and prevent the recurrence of breakdowns from initial use of products and quality changes that happen during the product distribution process, we provide free-of-charge repair and tuning services.

## Warranty Regulations

If a product breaks down during normal operation, we provide free repair services for 12 months from the date of purchase. Please note, however, that actual expenses are charged even during the warranty period in the following cases, based on relevant regulations.

1. Breakdown resulting from misuse or improper use, and breakdown resulting from inattentiveness in handling the product.
  2. Breakdown resulting from a fire or a natural disaster.
  3. Breakdown from inappropriate repair and alteration.
  4. Breakdown from foreign substances in the pipeline.
- 

**SAMYANG**  
SYSTEM GROUP



#48-14 Samjeong-dong, Ojeong-gu, Bucheon-si, Gyeonggi-do, 421-808, Korea  
Tel : 82-32-678-3121~3 Fax : 82-32-681-1117 [www.samyangsys.com](http://www.samyangsys.com) / [www.samyangvalve.com](http://www.samyangvalve.com)

**VOL.11 Year 2010 Month 12**  
**Publishing Office : SAMYANG VALVE CO., LTD.**

**\*Notes :** There are cases where standards and specifications are changed for product improvements, without prior notice.



TAKE CONTROL

[www.samyangsys.com](http://www.samyangsys.com)

**SAMYANG**  
SYSTEM GROUP

SAMYANG Valve

SAMYANG-Arca

SEM System

Eco-enerdigm



**SAMYANG VALVE CO., LTD.**

#48-14 SAMJEONG-DONG, OJEONG-GU, BUCHEON-SI, GYEONGGI-DO, 421-808, KOREA  
TEL\_+82.32.678.3121~3 / FAX\_+82.32.681.1117 [www.samyangvalve.co.kr](http://www.samyangvalve.co.kr)

- The colors of the products may be slightly different from the actual ones, due to the printing process.
- The product appearance, specifications, etc. are subject to change without prior notice for product improvements.